

Reference Unbundling Offer (RUO)

Copper & Fiber

Version ~~01/11/2018~~2.0.1

N.B. Version 2.0.1 is identical to the previously published version 2.0 except for the following two changes :

- Added lead time for VULA Interconnection in table of paragraph 3.7.1
- Added minimum billed length for FTTO Fbre Access Services below table of paragraph 9.3

Date	Status
27/ 03 /2015	Version dated 27/3/2015 before public consultation
30/06/2015	Version dated 30/06/2015 for public consultation
01/10/2015	Version dated 01/10/2015 applicable as of 01/10/2015
01/11/2018	Version dated 01/11/2018 for public consultation and applicable as of 01/11/2018
03/09/2019	Version 2.0 awaiting public consultation
27/09/2019	Version 2.0.1 for public consultation

Table of content

1. RUO Legal Terms	6
1.1. Services covered	6
1.2. Definitions and Interpretation Rules	7
1.3. Term	7
1.4. Amendments	8
1.5. RUO Tariffs	8
1.6. Billing	8
1.7. Parties' obligations	9
1.8. POST Technologies' General Powers	11
1.9. Limitation of liability	13
1.10. Property	13
1.11. Information exchange, confidentiality	14
2. RUO Operational Terms	17
2.1. Service description	17
2.2. Quality of Service – Service Level Agreement (SLA)	17
2.3. System protection	17
2.4. Configuration and technical constraints	18
2.5. Scheduled System Alteration	18
2.6. Works or intervention due to an POST Technologies' network failure or an emergency case	18
2.7. Coordination between the Parties	19
2.8. Relations with End Users and branding	19
3. Procedure for reaching an Unbundling Agreement	20
Schedule 1. Glossary	21
Schedule 2. Unbundling Service Description	26
2.2. Metallic Path Facility Sub-Loop Unbundling	29
2.3. Tie Cables and Rack Connection Facilities	30
2.4. FTTH Access – Local Loop Unbundling	32
2.5. Operator Rack Connection	37
2.6. VULA Services	40
2.7. Fibre-To-The-Office (FTTO) Services	43
2.8. Service Termination	50
Schedule 3. Planning, Ordering and Provisioning	50
3.1. Coordination between parties	50
3.2. Preliminary exchange of information	51
3.3. Electronic Information exchange	51
3.4. Forecasting	52
3.5. Provisioning Procedure for Metallic Path Facility	55
3.6. Provisioning procedure of FTTH Fibre Access Services	70
3.7. Provisioning procedure of VULA Services	76
3.8. Provisioning Procedure of FTTO Services	79
3.9. Key Performance Indicators	80
3.10. Non-standard Requests	80

Schedule 4. Fault Repair	82
4.1. Fault Reporting and Repair	82
4.2. End Users' liabilities	86
Schedule 5. Quality of Service - Service Level Agreement (SLA)	88
Schedule 6. Business SLA	89
6.1. Definitions related to the Business SLA	89
6.2. Terms and conditions of the Business SLA	89
6.3. Business SLA fault reporting and repair	90
6.4. Business SLA characteristics	91
6.5. Penalties	91
Schedule 7. Rush Orders	93
Schedule 8. Request for an Underground Connection	95
8.1. Request	95
8.2. Invoicing	95
8.3. End User contact for the realisation of the "raccordement souterrain"	95
Schedule 9. Tariffs	97
9.1. FTTH Fibre Access Service	97
9.2. VULA Service	99
9.3. FTTO Fibre Access Service	100
9.4. Metallic Path Facility (MPF)	101
9.5. Rush Order Fees for MPF, FTTH, FTTO and VULA Services	102
9.6. Fault Repair Fees for MPF, FTTH, FTTO and VULA Services	102
9.7. POST Technologies Manpower Fee – per hour	102
1. RUO Legal Terms	4
1.1. Services covered	4
1.2. Definitions and Interpretation Rules	5
1.3. Term	5
1.4. Amendments	6
1.5. RUO Tariffs	6
1.6. Billing	6
1.7. Parties' obligations	7
1.8. POST Technologies' General Powers	9
1.9. Limitation of liability	11
1.10. Property	11
1.11. Information exchange, confidentiality	12
2. RUO Operational Terms	15
2.1. Service description	15
2.2. Quality of Service – Service Level Agreement (SLA)	15
2.3. System protection	15
2.4. Configuration and technical constraints	16
2.5. Scheduled System Alteration	16
2.6. Works or intervention due to an POST Technologies' network failure or an emergency case	16
2.7. Coordination between the Parties	17
2.8. Relations with End Users and branding	17
3. Procedure for reaching an Unbundling Agreement	18

<u>Schedule 1. Glossary</u>	19
<u>Schedule 2. Unbundling Service Description</u>	24
2.2. Metallic Path Facility Sub-Loop Unbundling	27
2.3. Tie Cables	28
2.4. Fiber Access (FA) – Local Loop Unbundling	30
2.5. Fiber Access (FA) – Sub-Loop Unbundling	32
2.6. Operator Rack Connection	34
2.7. Fibre To The Office (FTTO) Services	37
2.8. Duct Sharing Service (DSS)	39
2.9. Service Termination	43
<u>Schedule 3. Planning, Ordering and Provisioning</u>	43
3.1. Coordination between parties	43
3.2. Preliminary exchange of information	44
3.3. Electronic Information exchange	44
3.4. Forecasting	44
3.5. Provisioning of Operator Rack connections	45
3.6. Provisioning of tie cable	47
3.7. Provisioning Procedure for Metallic Path Facility	49
3.8. Provisioning Procedure of DSS	60
3.9. Provisioning procedure of FA	63
3.10. Provisioning Procedure of FTTO Services	68
3.11. Key Performance Indicators	70
3.12. Non-standard Requests	70
<u>Schedule 4. Fault Repair</u>	71
4.1. Fault Reporting and Repair	71
4.2. End Users' liabilities	75
<u>Schedule 5. Quality of Service – Service Level Agreement (SLA)</u>	76
<u>Schedule 6. Business SLA</u>	77
6.1. Definitions related to the Business SLA	77
6.2. Terms and conditions of the Business SLA	77
6.3. Business SLA fault reporting and repair	78
6.4. Business SLA characteristics	79
6.5. Penalties	79
<u>Schedule 7. Rush Orders</u>	80
<u>Schedule 8. How to transmit the "Demande de raccordement souterrain" to POST Technologies by the Operator, on behalf of the End User</u>	81
8.1. Request	81
8.2. Invoicing	81
8.3. End User contact for the realisation of the "raccordement souterrain"	81
<u>Schedule 9. Access to POST Technologies's End User account numbers</u>	82
<u>Schedule 10. Tariffs</u>	83
10.1. Fibre Tie cables	83
10.2. Fibre Access Service (FA Service)	83

<u>10.3. FTTO</u>	84
<u>10.4. Actual POST Technologies Manpower fee – per hour</u>	84
<u>10.5. Copper tie cable</u>	84
<u>10.6. Metallic Path Facility (MPF)</u>	85
<u>10.7. Duct Sharing Services (DSS)</u>	85
<u>Schedule 11. Parameter Schedule</u>	86
<u>11.1. Provisioning of MPF</u>	86
<u>11.2. Provisioning of tie cables</u>	86
<u>11.3. Fault Reporting and Repair</u>	86
<u>11.4. Other</u>	87

1. RUO Legal Terms

This RUO defines the terms and conditions, which shall apply and be granted by POST Technologies to Operators ("**Operators**") for the provisioning of POST Technologies' LLU Services as required by Regulation ~~14/175/ILR/T19/3~~.

All Schedules attached to this RUO form an integral part hereof and detail the different LLU Services and their respective applicable provisioning terms offered by POST Technologies under this RUO.

The Co-Location services as referred to from time to time in this RUO are part of and subject to the applicable Reference Co-Location Offer ("**RCO**") and shall be provided by POST Technologies to the Operators in compliance with the specific terms and conditions of the said RCO.

As from the effective date of an Unbundling Agreement the Operator is subject to this RUO and any of its subsequent and/or to any reference offers replacing it, as from their date of definitive publication in compliance with the applicable regulations and, more particularly, in compliance with Regulation 14/177/ILR.

This RUO does not purport to diminish the rights of Operators to seek additional services nor POST Technologies' obligation to provide additional services under applicable law.

Apart from this RUO, POST Technologies' commercial offers as well as any other valid and applicable reference offer(s), if any, are still available to the Operator on request pursuant to their respective terms and conditions.

1.1. Services covered

This RUO defines the minimal terms and conditions for LLU Services which POST Technologies will grant to Operators.

Nevertheless, POST Technologies reserves the right to provide more beneficial terms and conditions on a commercial basis, in accordance with the applicable regulatory framework, including the principle of non-discrimination.

The LLU Services covered by this RUO are:

- (i) Unbundled fibre optic service
- (ii) Unbundled metallic path facility service,
- ~~(iii) Duct sharing service~~

A detailed description of these services is provided in Schedule 2.

LLU Services delivery and operations by POST Technologies shall be in accordance with the applicable Technical Information, as provided by POST Technologies to the Operator, which shall conform to the general principles set out in and form integral part of the RUO.

1.2. Definitions and Interpretation Rules

1.2.1. Definitions

Unless expressly stated otherwise:

- (i) References to an article are references to an article of the RUO, while references to clauses and schedules are to the clauses and schedules of the RUO; references to paragraphs are to paragraphs of the relevant schedule;
- (ii) Reference to a person includes a natural person, corporate or unincorporated body (whether or not having separate legal personality), while references to a statute or statutory provision is a reference to it as it is in force for the time being, taking account of any amendment, extension or re-enactment and includes any subordinate legislation for the time being in force made under it;
- (iii) A reference to one gender shall include a reference to the other genders and vice versa ;
- (iv) Words in the singular shall include the plural and vice versa, while references to a gender include any other gender;
- (v) Writing or written includes faxes but not e-mail, except if specifically specified in this RUO or in the Unbundling Agreement;
- (vi) Where the words "include(s)", "including" or "in particular" are used, they are deemed to have the words "without limitation" following them. The words "other" and "otherwise" are illustrative and shall not limit the sense of the words preceding them;
- (vii) Any obligation in the RUO or in the Unbundling Agreement on a person not to do something includes an obligation not to agree or allow that thing to be done.

1.2.2. Interpretation rules

To the extent that they are consistent with and the subject-matter of the provisions concerned have not been replaced by the terms of the RUO and/or the Unbundling Agreement, the General Terms and Conditions for Sale (GTCS) of POST Technologies, which can be consulted on POST Technologies' Website, will apply to the provision of the LLU Services.

Unless expressly defined otherwise hereafter (in particular in ~~Schedule 1~~ [Schedule 1](#) below), the terms used in this RUO shall be construed and interpreted in accordance with ~~the provisions of the Regulations of the European Parliament and the European Council on Unbundled Access to the Local Loop EU Regulation (EC) No. 2887/2000 and~~ the Law of February 27th, 2011 on ~~and~~ Electronic Communication Networks and Services and its implementing regulations.

1.3. Term

This RUO is valid as from the date of its definitive publication in accordance with Regulation 14/177/ILR unless the ILR advises otherwise or unless:

- (i) a new RUO is published or adopted by POST Technologies, in compliance with Regulation 14/177/ILR, or

- (ii) a material change occurs in the laws or regulations with respect to electronic communication services and networks in Luxembourg and this only to the extent that such a material change would render the RUO inapplicable or unenforceable.

1.4. Amendments

In accordance with Regulation 14/177/ILR the content of this RUO may be timely reviewed and amended in order to comply with applicable rules and regulations. However, amendments to the general conditions of POST Technologies and to the Technical Information can be made in accordance with the amendment provisions set forth therein.

Furthermore, ILR has the right to request or impose on POST Technologies modifications to the applicable RUO or the adoption of a new RUO to be undertaken by POST Technologies in compliance with the applicable procedural rules and regulations.

1.5. RUO Tariffs

All RUO Tariffs, including those specified in the Schedules attached hereto, are in EURO (€) and exclusive of Value-Added Tax (VAT) or any other legal taxes, which will be added where applicable. Please refer to ~~Schedule 9~~[Schedule 9](#)~~Schedule 10~~.

POST Technologies may revise the RUO tariffs at any time after having definitively published the reviewed RUO tariffs in accordance with Regulation 14/177/ILR.

If any RUO tariff or the means and/or methods of calculating such RUO tariff is subject to a legal review by the ILR or with any other administrative or judicial authority, the concerned RUO tariff or the concerned calculation method shall be treated as valid until the final conclusion of the legal review, unless the competent authority directs otherwise. If an authority finds a RUO tariff or a RUO tariff calculation method to be unlawful, then POST Technologies shall make any necessary alterations to RUO tariffs for the future.

1.6. Billing

The Operator undertakes to pay all invoices in relation to this Unbundling Agreement in EURO (€) and within the payment period specified on the relevant invoice(s), it being specified that the Operator shall pay to POST Technologies all due amounts as set forth above irrespective of (i) the billing by the said Operator to its own End User and/or of (ii) the payment by the End User(s) of the services provided to them by the Operator on the basis of or in relation to the LLU Services or any other telecoms service(s) provided by POST Technologies to the Operator.

Upon POST Technologies' request, the Operator shall provide an irrevocable and unconditional bank guarantee issued in favour of POST Technologies by an EU financial institution for an amount of at least 50.000 €:

before POST Technologies' acceptance of any order in case the Operator's creditworthiness appears to be not sufficient for the LLU Services to be provided by POST Technologies; or in case

the Operator has had repetitive credit defaults in the past towards POST Technologies, whichever may be the type of services concerned;

the Operator fails to make payment to POST Technologies of any undisputed amount when due in relation to the LLU Services; or

in case the Operator has a material, negative change in its financial conditions and/or creditworthiness.

The above-mentioned guarantee shall be issued for a period equivalent to the duration of the Unbundling Agreement, but may be extended having regards to the circumstances upon POST Technologies' request. When, and as long as serious and ascertained doubts exist regarding the Operator's creditworthiness or solvency, POST Technologies may without prejudice to previous arrangements require payment in advance.

1.7. Parties' obligations

1.7.1. POST Technologies shall be responsible for:

- (i) the access network used to provide the LLU services.
- (ii) connecting or disconnecting tie cables and individual access lines in response to Operator confirmed orders submitted to POST Technologies in accordance with ~~Schedule 3~~ Schedule 3 – Planning, Ordering and Provisioning.
- (iii) providing billing information, as specified in Article ~~1.61.6~~.
- (iv) conducting tests, if need be, in the context of cable and spectrum management.
- (v) to protect the integrity of the access network.
- (vi) informing Operators on system alteration to be made in the network and having potential effect on the services offered by the Operator, all these subject to the terms and conditions of as well as to the extent of this RUO.
- (vii) the maintenance of the LLU Services between the POI with the Operator and the network termination point (NTP/FO-NTP) on the End User's premises. POST Technologies shall not be responsible for any additional cabling between the network termination point and the End User's exact location within the premises.

POST Technologies shall not be responsible for :

- (i) the performance and follow-up of any service that the Operator operates on a LLU Access and provided to the latter as part of the LLU Services ;
- (ii) the provision to the Operator of a Metallic Path Facility before the Operator has confirmed to POST Technologies in writing that the equipment that the Operator proposes to attach to the Metallic Path Facility is and will remain Compliant Equipment and will operate within the limits of the specifications defined in the applicable RUO ;
- (iii) POST Technologies shall in no case be obliged to expand, modify or condition in any way POST Technologies' Network in whole or in part, to provide any part of the LLU Services, unless

- a. where a NTP does not exist, but is technically possible (and the physical address is located in a zone covered already by POST Technologies' access network) and has been asked for, whereby the "demande de raccordement souterrain" may be transmitted to POST Technologies by the Operator, on behalf of the End User, and only to the strict extent as specifically needed ;
- b. expressly agreed otherwise in the Unbundling Agreement and only to the strict extent as specifically agreed upon by and between the Parties ;
- c. if and to the extent that such expansion, modification or conditions has been imposed by ILR.

Request for new connections to existing and/or new buildings shall be handled pursuant to ~~Schedule 3~~Schedule 3 – Planning, Ordering and Provisioning.

1.7.2. The Operator shall at least be responsible for the following:

- (i) ordering or terminating, as the case may be, a LLU Service in accordance with ~~Schedule 3~~Schedule 3– Planning, Ordering and Provisioning;
- (ii) using exclusively telecommunications terminal equipment compliant with "*Règlement grand-ducal du 4 février 2000 concernant les équipements hertziens et les équipements terminaux de télécommunications et la reconnaissance mutuelle de leur conformité*" and any subsequent regulations replacing or amending this regulation, as well as with any specifications provided by POST Technologies in accordance with the terms of this RUO;

The Operator shall not connect or knowingly permit the connection to the MPF of anything that is not Compliant Equipment. The Operator shall ensure that such Compliant Equipment remains compliant with relevant standards including, without limitation, EMC requirements and electrical safety. The Operator shall comply with POST Technologies' reasonable instructions on floor loading and heat output before installing any Compliant Equipment at an MDF Site.

The Operator shall not connect Compliant Equipment or any other equipment within an MDF Site to any Third Party Operator's equipment in an MDF Site or to the Network of any Third Party Operator save only where necessary for the purpose of providing telecommunication services to End Users over MPFs and shall not use the Compliant Equipment for any purpose other than that which is specifically permitted by the RUO and/or the Unbundling Agreement. For the avoidance of doubt this shall not prevent the Operator and Third Party Operator(s) within the same Operator Co-Location Equipment Room from sharing backhaul links.

- (iii) conducting appropriate fault testing and timely producing associated Fault Reports to evidence faults in the POST Technologies' network in accordance with this RUO and in particular with ~~Schedule 4~~Schedule 4 - Fault Repair;
- (iv) complying with any obligations of or related to legal interception;
- (v) informing the relevant End User about all technical modifications required on his/her existing installation and the service impacts that might occur; and

- (vi) tracking POST Technologies' system alteration activities as well as achieving relevant steps and actions in due time in order to make sure that the End User's services are maintained;

In order to allow the Operator to do so, POST Technologies will provide in actual real time changes (daily) information regarding such alteration activities to the Operator in the file "concentration points" published on POST Technologies Website. Furthermore, new projects are announced by POST Technologies in due time by mail and/or e-mail.
- (vii) notify POST Technologies in writing of its contact details relevant for or in relation to the LLU Services as of the signature date of the Unbundling Agreement as well as notify any change thereto to POST Technologies in due time and in any case sufficiently in advance in compliance with the Unbundling Agreement.
- (viii) Ensuring that all its staff and subcontractors intervening in relation to this RUO had the relevant experience and be appropriately skilled and trained to properly and timely comply with the terms and conditions of this RUO.
- (ix) Properly informing POST Technologies for the purpose of and in relation to the LLU Services and the RUO.
- (x) Cooperate with POST Technologies' reasonable requests for and/or in relation to the provisioning of the LLU Services.

1.7.3. No Operator (including POST Technologies) shall be responsible for the content of IP traffic or transactions passed through its own or an Operator's network (including POST Technologies' network). Laws and regulations regarding confidentiality and access by legal authorities to traffic or transactions on the Operator's and POST Technologies' network will apply.

1.8. POST Technologies' General Powers

- 1.8.1. POST Technologies may refuse to grant access to any LLU Services to any Operator for justified technical constraints or the necessity to warrant POST Technologies' network's integrity. Any decision to refuse to grant access will be notified to the ILR.
- 1.8.2. Occasionally, POST Technologies, acting reasonably, may suspend in whole or in part the LLU Services for any of the following reasons:
 - (i) if required by any administrative or judicial authority duly authorised and empowered to do so, or
 - (ii) for maintenance reasons, network adaptations and/or in case of any usage creating perturbations or disruptions of any part of the LLU Services or of any other service(s) using the same infrastructure.
 - (iii) in order to ensure the general availability of the LLU Services
 - (iv) when POST Technologies has reasonable grounds to believe that the Operator is using equipment or is permitting the use by the End User of equipment which is not Compliant Equipment.

1.8.3. Wherever possible, POST Technologies will give the Operator reasonable written notice before performing any of the actions related to the above and POST Technologies will do its best efforts to restore MPF or FA service as soon as possible after the concerned temporary suspension. POST Technologies shall give on the Operator's reasonable request a detailed written technical report after any incident having had a major impact on the Operator's services. This shall enable the Operator to clearly understand the source of the issue. In case the information provided by POST Technologies is manifestly insufficient, the Operator may request further information. POST Technologies shall reply within a maximum of five (5) Working Days after the day of such request.

1.8.4. POST Technologies shall have the right to disconnect any equipment or any part of it without prior reference or notice to the Operator if at such time, in POST Technologies' reasonable opinion, it is exposing or could expose any person to any danger of death or injury.

When POST Technologies is investigating a report of interference to POST Technologies' or any Third Party Operators' services, the Operator shall on request provide to POST Technologies, insofar as the Operator is able to do so, technical information relating to the equipment attached to the MPF and the signals generated by that equipment. The information requested shall be limited to that necessary to resolve the interference problem and used solely for the purpose of resolving that problem. If POST Technologies reasonably considers the equipment used by the Operator is not Compliant Equipment, the Operator shall on request from POST Technologies disconnect all necessary equipment in order to permit POST Technologies to test the characteristics of the MPF concerned.

1.8.5. Without prejudice to the foregoing clauses, POST Technologies shall have the right to request the Operator to disconnect any equipment or any part of it within a reasonable time period, if, at such time, in POST Technologies' reasonable opinion, it is causing, suspected of causing or could cause damage to the Network, a MDF or ODFFA Site, POST Technologies' telecommunications or electronic communications apparatus or any other property or if such exposure or damage is or may cause damage to health of the staff or may be imminent. POST Technologies will immediately notify the Operator of the circumstances in which such compliant equipment has to be disconnected. If the Operator has not disconnected the concerned equipment within a reasonable time period, POST Technologies shall have the right to disconnect itself the concerned equipment after prior notification thereof to the Operator.

1.8.6. POST Technologies shall not be liable to the Operator for any loss, damage or injury arising due to POST Technologies' action in disconnecting the equipment or for any interruption to the service provided by the Operator using the equipment howsoever caused, except where the loss damage or injury is caused directly due to POST Technologies' gross negligence.

1.8.7. In the event of a disconnection in accordance with the above, the Operator shall not reconnect the equipment until the reasons for its disconnection have been fully remedied. In case the danger or threat referred to above is caused directly due to POST Technologies' negligence, then POST Technologies shall reimburse to the Operator the evidenced reasonable direct costs of reconnecting the equipment.

1.9. Limitation of liability

- 1.9.1. POST Technologies has no obligation of any kind to the Operator beyond the obligations to exercise the reasonable skill and care of a competent telecommunications operator in performing its obligations under the RUO and the Unbundling Agreement.
- 1.9.2. Neither Party undertakes any liability for the acts or omissions of a third provider of telecommunications services, nor shall be held liable for such act or omission. As a consequence, the Party affected by such an act or omission shall carry out all appropriate rights and measures against the concerned third party provider of telecommunications services, without involving the other Party, while the latter will, if appropriate having regards to the circumstances, reasonably cooperate with the concerned other Party in relation to the above.
- 1.9.3. Neither POST Technologies nor the Operator excludes or restricts its liability for death or personal injury caused by its own negligence or liability.
- 1.9.4. POST Technologies will not be liable to the Operator for any claims, proceedings or actions brought or made against POST Technologies by any of the Operator's End Users, it being specified that in such case the Operator shall keep POST Technologies free and harmless of any such claims, proceedings or actions.
- 1.9.5. Neither Party shall be held liable to the other in contract, tort or otherwise, to the fullest extent permitted by law, for indirect or consequential damage or any other loss of profit whatsoever arising in connection with the implementation of this RUO and the relevant Unbundling Agreement, howsoever caused.

1.10. Property

All relevant infrastructures and equipment used by POST Technologies for the provision of LLU Services to the Operator remains and shall remain the integral property of POST Technologies.

The Operator shall be responsible for any equipment put at disposal by POST Technologies and must take reasonable steps to ensure that nobody (other than someone expressly authorised by POST Technologies) adds to, modifies or in any way interferes with it. The Operator will be liable to POST Technologies for any loss of or damage to POST Technologies' equipment, except where such loss or damage is due to fair wear and tear or is caused by POST Technologies, or anyone acting on POST Technologies' behalf.

Any software and/or user manuals provided or made available by POST Technologies to the Operator in relation to any part the LLU Services:

- (i) are and shall remain protected by applicable copyright law and as such, any copy, translation, transcription, bearing, correction, integration modification thereof, whichever may be the type, support, way and/or extend thereof, either by the Operator or by an End User, is strictly prohibited; and
- (ii) shall remain the exclusive property of, as the case may be, POST Technologies or any third party having title thereto.

The Operator expressly undertakes to take and/or cause to take all and all necessary or appropriate steps and measures to prevent any breach of the above provisions.

With the cessation of any part of the LLU Services either by the Operator or by a specific End User, whatever the reason, any usage rights of the Operator on that relevant infrastructure, software and/or user manuals shall automatically expire on the effective cessation date of the LLU Services, without POST Technologies having to carry out any specific steps in relation thereto and/or for that specific purpose and without prejudice to the right of POST Technologies to recover any physical elements that are its property.

If an End User terminates the telecommunication service(s) provided by the Operator by means of the RUO, the Operator shall submit a handback order in a time frame of maximum three (3) months and according to the procedure defined in ~~Schedule 3~~ [Schedule 3](#) – Planning, Ordering and Provisioning so that the MPF ~~or Fiber Access, FA or FTTO~~ service may then be marked as available for re-use by any other Operator including POST Technologies.

1.11. Information exchange, confidentiality

1.11.1. In order to implement the RUO and the Unbundling Agreement, POST Technologies and the Operator will have to exchange information and the disclosing Party undertakes to use reasonable endeavours to ensure that the information disclosed is correct to the best of its knowledge at the time of such information provision.

1.11.2. The POST Technologies Staff is under professional secrecy. This legal obligation binds the personnel to secrecy concerning the Operator, as well as its services and data (including those of its End Users).

1.11.3. With respect to each and any Confidential Information provided by either Party (the "Disclosing Party") to the other (the "Receiving Party") in relation to this Agreement, the Receiving Party undertakes to:

- (i) hold such Confidential Information in confidence and protect it with the same degree of care with which it protects its own Confidential Information of equivalent importance, but in no event less than reasonable care;
- (ii) use such Confidential Information only in pursuance of its business relationship with the other Party and its Affiliates as well as in relation to the Unbundling Agreement and/or the LLU Services;
- (iii) not copy or otherwise duplicate in whatever form and on whatever support or mean either known or unknown to date (e.g. in written, pictorial, floppy disks, magnetic disks, optical disks or other tangible form) such Confidential Information or knowingly allow anyone else to access, copy or otherwise duplicate any of such Confidential Information under its control without the Disclosing Party's prior written approval (which shall not be unreasonably refused, delayed or conditioned), except as regards to Authorised Persons as defined below;
- (iv) restrict access to and disclosure of such Confidential Information solely to those of its employees (including its management and directors), external advisors and/or consultants and any of those of its Affiliates and/or of those of its Subcontractors with a strict need to know and directly involved in the implementation of this Agreement and/or in the provision of any part(s) of the Services (collectively the "Authorised Person(s)"), and not to disclose Confidential Information to any third parties (including, without limitation, any of its other agents, consultants and/or subcontractors not being Authorised Persons); as well as

- (v) require that all Authorised Persons to which access to the Confidential Information has been or will be granted or given duly agree to maintain the confidentiality thereof, and specifically to comply with the provisions set forth herein by contract, work rules or other appropriate methods at the Receiving Party's option; and
- (vi) not analyse or reverse engineer for composition of any Confidential Information, nor assist others to disassemble, decompile, reverse engineer or otherwise attempt to recreate the Confidential Information.

1.11.4. Each Party shall take all reasonable steps and measures to:

- (i) avoid disclosure, dissemination and more generally unauthorised access to or use of Confidential Information, which shall comply with the measures it usually takes to protect its own confidential information or its information of a similar nature and in any case take not less than reasonable care; and
- (ii) segregate Confidential Information from third parties' confidential materials, in particular to prevent commingling; and

at its sole expense and including but not limited to court proceedings, to restrict its Authorized Persons from prohibited or unauthorized disclosure or use of the Confidential Information as well as to make each of them sign individual secrecy commitments at least equivalent to those contained in the Unbundling Agreement. This Article ~~1.114.11~~ shall nevertheless not prevent or refrain any Party from complying with its legal information obligations.

1.11.5. The Receiving Party may in particular disclose Confidential Information to European or national competent governmental or administrative authorities to the extent strictly necessary to ensure compliance with any law.

In case Confidential Information is to be communicated pursuant to the requirement of law, regulation, judgment, order from any competent administrative authority or judicial body and/or request for the needs of any proceedings with any courts or administrative authorities, having the right to request the disclosure of such a Confidential Information, the Receiving Party shall, to the extent permitted by any applicable law or the relevant regulation, authority or body, notify such request for disclosure to the Disclosing Party without undue delay upon receipt thereof so that the Disclosing Party may, at its sole discretion and costs, seek protective order, confidential treatment and/or other appropriate remedy. In any case, the Receiving Party shall be entitled to disclose such Confidential Information as strictly requested by the relevant authority, provided it duly specifies to the said authority at the time of such disclosure the confidential nature of such Confidential Information and takes all relevant steps to ensure due protection thereof to the widest extent possible.

- 1.11.6. The Receiving Party shall notify to the Disclosing Party, immediately upon discovery or knowledge thereof, any unauthorised use, access and/or disclosure of any Confidential Information or any other breach of this Article ~~1.111.11~~ and undertakes in such a case to (i) reasonably cooperate with and support the Disclosing Party and/or its Affiliates to protect its/their rights and when relevant to regain possession of such Confidential Information as well as to mitigate the consequences of such unauthorised use, access and/or disclosure, to (ii) take out and achieve without undue delay all appropriate and relevant steps and measures to prevent further unauthorised use, access and/or disclosure of the Confidential Information or part thereof and to (iii) take appropriate defensive measures against any claim of infringement, in accordance with the reasonable instructions of the Disclosing Party.
- 1.11.7. All Confidential Information shall remain the property of the Disclosing Party and/or as relevant of the owner of the concerned Confidential Information.
- 1.11.8. The Parties agree that the provisions strictly relating to confidentiality set forth in this Article ~~1.111.11~~ shall survive any termination of the Unbundling Agreement, whichever may be the ground, for a three years (3) period as from the effective termination date of the Unbundling Agreement.
- 1.11.9. The Parties hereby declare and warrant that they comply with data protection and privacy laws, and any other laws in relation to the LLU Services, to the extent applicable to them. Each Party particularly undertakes to (i) comply with the legislation in force relating to personal data protection and computer security, including in particular the amended law of 2 August 2002 on the protection of persons with regard to the processing of personal data as well as the amended law of 30 May 2005 on the protection of privacy in the electronic communications sector (ii) hold and maintain such security infrastructure and organization as relevant or necessary to comply with and reasonably carry out its rights and obligations pursuant to this Agreement under optimum safety condition and in compliance with applicable laws.

2. RUO Operational Terms

2.1. Service description

The Unbundling Services shall:

- (i) Be provided by POST Technologies to an Operator in accordance with the terms and conditions of this RUO;
- (ii) Consist of the following services:
 - a. Provisioning by POST Technologies to an Operator of a MPF (Metallic Path Facility), ~~FTH (Fibre-To-The-Home) A (Fibre Access)~~, ~~or~~ FTTO (Fibre-To-The-Office) ~~Fibre Access or VULA~~ Service to enable the Operator to provide electronic communications and telecommunications service(s) to End Users, or
 - b. Transfer of an existing metallic ~~(copper)~~ or fibre service from POST Technologies to the Operator, provided this is part of an active loop or an active sub loop;
 - c. ~~Provisioning of DS (Duct Sharing) Services.~~

2.2. Quality of Service – Service Level Agreement (SLA)

The Service level set out in ~~Schedule 5~~ Schedule 5 attached hereto shall apply by default to the provision of the Unbundling Services and is in line with the service level granted by POST Technologies to all Operators, while the said Service level shall not apply in case of any Force Majeure event.

POST Technologies makes available a Business SLA, which may be specifically opted in by the Operator per Unbundling Service for the benefit of professional End Users exclusively and which contains the Service levels set out in ~~Schedule 6~~ Schedule 6 – Business SLA.

2.3. System protection

Each Party is responsible for the safe operation of its respective system and shall take all reasonable and necessary steps and measures in its operation, implementation and maintenance to ensure that its system does not:

- (i) endanger the safety or health of employees, contractors, agents or End Users of the other Party, nor
- (ii) damage, interfere with or cause any deterioration in the operation of the other Party's system or a third party Operator's system.

2.4. Configuration and technical constraints

- 2.4.1. Unbundling Services will be provided in accordance with the technical constraints specified in ~~Schedule 2~~ [Schedule 2 – Unbundling Service Description](#)
- 2.4.2. POST Technologies shall in no case be liable for any shortage of access lines or cable saturation, e.g. due to broadband usage.

2.5. Scheduled System Alteration

2.5.1. Scheduled system alteration with major impact

When POST Technologies wants to make a system alteration which may reasonably have a major impact on the proper provision of the LLU Services under this RUO to one or several Operator(s), it shall give to the concerned Operator(s) a minimum two (2)-month written notice prior to the foreseen date of the anticipated system alteration, which shall specify the technical details of the contemplated system alteration and the foreseen date of the said anticipated system alteration.

Following such notification, POST Technologies shall provide to the Operator additional information, as the Operator may reasonably request, including, to the extent reasonably practicable, the potential impact thereof on the service(s) provided by the Operator to the End Users.

Upon an Operator's express request, POST Technologies will grant access to a special test platform where the said Operator can test the compatibility of its Active Equipment with the latest software version applied in POST Technologies' Network. A complete catalogue of rules for the operator's perusal will be published and kept up to date on the following website: www.posttechnologies.lu. This catalogue will allow the Operator to ensure its technical compatibility with POST Technologies' infrastructure

Scheduled system alteration without major impact

When POST Technologies wants to make a system alteration which may reasonably not have a major impact on the proper provision of the LLU Services under this RUO to one or several Operator(s), it shall give to the concerned Operator(s) a prior notice having regards to the circumstances which shall in no case be less than three (3) Working Days prior to the foreseen date of the said anticipated system alteration. Such notification shall specify the technical details of the contemplated system alteration, the foreseen date of the related works and the reasonably foreseeable impact of the said works on the LLU Services provisioning.

2.6. Works or intervention due to an POST Technologies' network failure or an emergency case

In case POST Technologies has to intervene on its network further to a network failure or an emergency case, POST Technologies will do its best efforts to limit the time of its intervention having a possible impact on the provisioning of the LLU Services to the reasonable minimum time having regards to the circumstances. In any case, POST

Technologies will inform the Operators of such an intervention as soon as reasonably possible, while the restoration of the service provisioning on POST Technologies' network shall be the priority.

2.7. Coordination between the Parties

The POST Technologies' and the concerned Operator's respective contact points in relation to this RUO and to the provision and maintenance of the Unbundling Services are or, as the case may be, will be specified in the concerned Unbundling Agreement and/or in ~~Schedule 3~~[Schedule 3](#)– Planning, Ordering and Provisioning. In addition POST Technologies will publish its contact points on POST Technologies' Website, while the later version thereof shall always prevail over older ones.

2.8. Relations with End Users and branding

2.8.1. End Users

Without prejudice to the applicable regulatory framework, POST Technologies will not undertake customer handling/care of the Operator's End Users.

The Operator undertakes not to include in the contractual terms with its End Users conditions that are not consistent with the terms of the RUO. The Operator shall be solely liable and responsible for any contractual terms and conditions that the Operator may offer to its End Users beyond the specifications of the Unbundling Services.

2.8.2. Branding

The Parties agree not to offer any Unbundling Service under any brand, including any trademark, trade name or company name of the other Party unless the use of the brand(s) of the other Party is expressly agreed upon in writing between the Parties. Such use of the brand will then be strictly limited to the service at stake.

POST Technologies is allowed to use, for all interventions in the context of this RUO, its normal vehicles and staff uniforms with all advertising on them as for its own products and services.

The Operator is not allowed to attach any branding or advertising signs on POST Technologies' equipment and infrastructure, neither in POST Technologies' sites nor in End User's sites.

3. Procedure for reaching an Unbundling Agreement

Unbundling Agreements will be negotiated and entered into, based on POST Technologies' standard terms and conditions, pursuant to and in compliance with the applicable legislation and POST Technologies shall endeavour its best efforts to conclude an Unbundling Agreement in no less than fifteen (15) days after receipt of a valid request.

In case of request from an operator that is not covered by one of POST Technologies reference offers, POST Technologies shall endeavour its best efforts to conclude an Agreement in no less than three (3) months after receipt of a valid request.

Any request for entering into an Unbundling Agreement with POST Technologies under this RUO must be made in writing and per registered mail to the following address:

POST Technologies

Département Développement et Vente en gros

2, rue Emile Bian

L-1235 Luxembourg

Tel: +352 49 91 1

Schedule 1. Glossary

(In the event of doubt, the description in the relevant text prevails to the definition given here)

Defined Terms	Meaning
Active Local Loop	Continuous copper pair or fibre in the local loop between the Network Termination Point (NTP or FO-NTP) and the Main Distribution Frame (MDF) or Optical Distribution Frame (ODF) providing service to the End User.
Active Sub Loop	Continuous copper pair or fibre in the local loop between the Network Termination Point (NTP or FO-NTP) and a concentration point or a specified intermediate access point providing service to the End User.
ADSL	Asymmetrical Bit-Rate Digital Subscriber Line, being ADSL 1, ADSL 2 or ADSL 2+.
Area POP	A POP in POST Technologies FTTH network from which access to POST Technologies' point-to-point fibre optic local networks is granted. In general, an Area POP gives fibre access to customers in the proximity of this Area POP. The ODF, the Operator Racks and POST Technologies' Racks are in the same room. For the sake of clarity it should be noticed that existing CO sites can also serve as termination point for the point-to-point fibre infrastructure.
Business Hours	From Monday to Friday, 08:00-12:00 and 13:00-17:00, except on public, legal or usage holidays in Luxembourg.
Call-back Delay	The Call-back Delay is the duration calculated from the Incident Ticket opening until the first returned call or email by POST Technologies to the Operator.
Calendar	Time sheet defining for each Operator the maximum number of appointments per day agreed with POST Technologies for MPF activation/migration, it being specified that this Calendar shall be used by the Operator to exchange the End User's appointments with POST Technologies.
Co-Location	The provision by POST Technologies of physical space and technical facilities necessary to reasonably accommodate and connect the relevant equipment of an Operator.
Co-Location Equipment Room	Physical space in POST Technologies site allocated for Co-Location purposes.
Co-Location Space	Specific physical space(s) reserved by POST Technologies in a given Co-Location Equipment Room for a given Operator according to the needs expressly specified by the latter.
Commencement Date	Forecasting term for a date when e.g. a Service will start.
Confidential Information	Includes, without limitation, <ol style="list-style-type: none"> all non-public information relating the technology, infrastructure, customers, business plans and business models, tariffs and prices, promotional and marketing activities, strategy, finances, and other business affairs, possible routes, needs, constraints and/or requirements, offers and/or potential or possibly involved Subcontractors or providers relating to any Party and/or its Affiliates; all third party information that the concerned Party and its Affiliates are obliged to keep confidential; as well as any possible combination of any of the above and excludes information which <ol style="list-style-type: none"> was in the legitimate possession of the Receiving Party (as defined below) at the time of its disclosure by the Disclosing Party (as defined below) or corresponds in substance to information developed by the Receiving Party, as it can be demonstrated on the basis of previously existing documents, and

	<p>which was not previously acquired from the Disclosing Party on a confidential basis;</p> <p>b. was in the public domain at the time of its disclosure by the Disclosing Party to the Receiving Party, as it can be demonstrated on the basis of published documents which were generally available prior to the disclosure of the relevant information;</p> <p>c. is considered to be part of the public domain subsequent to its disclosure by the Disclosing Party to the Receiving Party, as it can be demonstrated on the basis of documents which were published and are generally available through no act or failure to act of the Receiving Party; and</p> <p>d. was disclosed by a third party to the Receiving Party without restriction on disclosure or use, unless the Receiving Party had actual knowledge that the third party acquired possession of it unlawfully or by a breach of contract or a fiduciary relationship.</p>
CPM	Cable Pair Management Plan.
Disclosing Party	The party in a Unbundling Agreement handing over Confidential Information.
Distribution Cable	The copper cable located behind the street cabinet in the direction of the relevant End User's Premises.
DS	Duct Sharing.
DSS	The DS services that POST Technologies offers to provide, subject to the terms and conditions of this RUO, to the Operator.
End User	Any natural or legal person with whom POST Technologies or Operator(s) has entered into an agreement for the provision of publicly available telecommunication services.
EPT	Entreprise des Post OSTes et des Télécommunications, an autonomous "Etablissement public" created by the "Loi du 10 août 1992 portant création de l'Entreprise des POSTes et Télécommunications", as further modified.
ETS	European Telecommunication Standards.
FA	Fibre Access
Fault Report	As the case may be, either written report sent by Operator to POST Technologies in case of faults discovered within the Local Loop Unbundling (LLU) service
FCP	Fault Contact Point.
Feeder Cable	The copper cable between the Main Distribution Frame (MDF) at the POST Technologies Local Exchange and the street cabinets (also referred to as "backhaul cable") :-
FO-VZ	Intermediate optical distribution frame.
FO-NTP	The termination point of the fibre optic section at the relevant End User's premises at which point the POST Technologies' access network ends.
Force Majeure	A force majeure event as defined in the GTCS
Forecast	The process of Operator's forecasting future demands of LLU and DS services
FTTB	Fibre To The Building
FTTC/FTTB	Fibre To The Curb / Fibre To The Building.
FTTH	Fibre To The Home
FTTN	Fibre To The Node
FTTO	Fibre To The Office
GTCS	General Terms and Conditions for Sale of POST Technologies, which can be consulted on POST Technologies' Website
HDF - Handover Distribution Frame	The HDF will be located in the Operator specified Co-Location area. The HDF includes only the "iron work" and will be provided by the Operator, while the termination blocks of the tie cables to be fixed on the HDF will be provided by POST Technologies together with the ordered tie cables.
HDSL	High Bit-Rate Digital Subscriber Line.

ILR - Institut Luxembourgeois de Régulation	The national regulatory authority in Luxembourg.
Incident Ticket	The written confirmation notice to be sent by POST Technologies to Operator FCP (i) upon opening of an incident ticket after receipt of a valid Fault Report communicated by the Operator to relevant POST Technologies FCP and specifying POST Technologies' reference number of the concerned incident ticket ("Incident Ticket Opening") and afterwards (ii) upon closing of the relating incident ticket, either after remedy of the concerned fault or after closure of the Fault Report for any other valid reason ("Incident Ticket Closing").
Intervention time	The intervention time is the duration calculated from the concerned Incident Ticket Opening to the Operator until POST Technologies intervenes in order to repair the circuit.
LLU	Local Loop Unbundling (either copper or fibre)
Unbundling Agreement	The agreement between POST Technologies and the concerned Operator, including the schedules and if relevant amendments thereto, covering LLU Services and which has already been executed prior to the entry into force of this RUO and shall be automatically amended thereby, or which will be later on executed for the purpose of and in compliance with this RUO, which shall be an integral part thereof.
LLU Services	Unbundling services, including as the case may be (i) metallic path facility, (ii) fiber access, (iii) VULA as full local loop or sub-local loop.
Local Exchange	The telephony exchange closest to a given End User.
Local Loop	The physical twisted metallic pair or fibre circuit connecting the network termination point at the relevant End User's premises to the main or optical distribution frame or equivalent facility in the fixed public network.
Local Sub-Loop	A partial local loop (copper) or fibre connecting the network termination point at the relevant End User's premises to a concentration point or a specified intermediate access point in the fixed public network.
MDF - Main Distribution Frame	The termination point of the raw copper circuit in POST Technologies' Local Exchange building.
MPF - Metallic Path Facility	A twisted pair of fully metallic continuous unequipped copper wires on the section between POST Technologies' MDF at the POST Technologies Local Exchange and the relevant End User's address connected on a Network Termination Point if it exists or if it is possible to provide.
MDU	Multi Dwelling Unit (Apartment blocks)
MPFNP	MPF combined with Number Porting order type for migration of a phone line to an MPF service, previously linked to Number Porting (NP)
MSN	Multiple Subscriber Numbers.
Non-Active Local Loop	A Local Loop that is not actively used by POST Technologies to provide a telecommunication service to a specific End User before the unbundling of the Local Loop is requested.
Non-Active Local Sub Loop	A Local Sub Loop that is not actively used by POST Technologies to provide a telecommunication service to a specific End User before the unbundling of the Local Sub Loop is requested.
NTP - Network Termination Point	The termination point of the access line section at the relevant End User's premises at which point the POST Technologies' access network ends.
ODF	Optical Distribution Frame.
ODF Site	Termination point of the fibre section at the relevant POST Technologies Fibre POP of the fibre optic point-to-point infrastructure.
OHDF	Optical Hand Over Frame – termination panels provided and installed by POST Technologies in outside shelters (Type C Fibre POP) to terminate the RCF in the context of fibre unbundling sFA Services.

Operator	Any legal or natural person exploiting telecommunications networks and/or providing telecommunications services in Luxembourg.
Operator Access Point	The physical interface within the Operator's System at which the Interconnection Services can be obtained.
Operator FCP	The Fault Contact Point provided by the Operator for the relevant End User and POST Technologies.
Order Forecast	Written plan to be submitted by the relevant Operator to POST Technologies and stating Operator's future orders for LLU and DS Services provided by POST Technologies.
Party	As the case may be, either POST Technologies or the Operator with which a Unbundling Agreement is (being) concluded.
Parties	POST Technologies and the Operator with which a Unbundling Agreement is (being) concluded.
Penalty	The Penalty is a lump indemnification amount to be credited to the Operator upon written express request to POST Technologies' relevant contact point for Business SLA as specified in the Business SLA Agreement
POI	Point Of Interconnect, the demarcation point between POST Technologies' and the Operator's physical Network.
<u>POST Luxembourg</u>	<u>Name used in all its commercial relationships by the "Entreprise des Postes et Télécommunications, an autonomous "Etablissement Public" created by the "Loi du 10 août 1992 portant création de l'Entreprise des Postes et Télécommunications" as further modified.</u>
POST Technologies	Telecommunications division of EPT
POST Technologies Access Point	The physical interface within POST Technologies' network at which the interconnection services as referred to and defined in the RIO can be obtained.
POST Technologies FCP	The Fault Contact Point provided by POST Technologies to the relevant End User and the Operator for addressing Fault Reports.
POST Technologies Infrastructure	The civil infrastructure of POST Technologies' network used in relation to or for the purpose of electronic communications, including ducts, splicing chambers, manholes, street cabinets, Co-Location Equipment Rooms, etc.
POST Technologies' Website	http://www.posttechnologies.lu/en/operators
POTS	Plain Old Telephone System.
Provisioning Time	Time period needed for the survey and the time period needed for the delivery of a LLUFA Service after a firm order.
PSD	Power Spectral Density.
PSM	Power Spectrum Management.
PSTN	Public Services Telephone Network.
RCF - Rack Connection Facility	Physical connection between POST Technologies' ODF and Operator's rack. The physical RCF implementation depends on the Fibre POP type <u>(also referred to as "tie cable")</u> .
RCO - Reference Co-Location Offer	The applicable POST Technologies' reference offer for Co-Location services in force.
Ready for Service Date	Date at which a given LLU Service should be ready for operational use.
RDSLØ	Reference DSL Offer.
Receiving Party	The Party in an agreement receiving Confidential Information.
RFS	Ready for Service.
ROBRLO	Reference Offer for Broadband ServicesReference Line rental Offer.
RTROB	Remote Terminal locationReference Offer for Broadband Services
RUORT	The present Reference Unbundling Offer,Remote Terminal location
<u>Schedule(s)RUØ</u>	<u>The schedule(s) attached to this RUØ, as listed in its table of contentsThe present Reference Unbundling Offer.</u>

SDSL Schedule(s)	Symmetric Single pair High Bit Rate Digital Subscriber Line. The schedule(s) attached to this RUO, as listed in its table of contents
SLA- Service Level Agreement SDSL	The standard SLA offered by POST Technologies for the LLU Services under this RUO or, upon the Operation's express option for professional End Users only, the Business SLA. Symmetric Single pair High Bit Rate Digital Subscriber Line.
Shelter SLA- Service Level Agreement	Building or container housing telecom equipment. The standard SLA offered by POST Technologies for the LLU Services under this RUO or, upon the Operation's express option for professional End Users only, the Business SLA.
Shelter	Building or container housing telecom equipment
SLCP(s) - Sub Loop Connection Point(s) Short-Term Forecast	The relevant Sub Loop Connection Point(s) referred to under this RUO are defined in a separate document published on POST Technologies' Website. Forecast covering next coming 1-6 months as of the date of its issuance.
SLCP(s) - Sub Loop Connection Point(s)	The relevant Sub Loop Connection Point(s) referred to under this RUO are defined in a separate document published on POST Technologies' Website.
SLUSLLS	Sub-Loop (copper) Unbundling Shared Local Loop Service offered by POST Technologies as defined in this RUO.
SPOC LLU	The Single Point Of Contact provided by either Party to the other for the purpose and within the frame of the Unbundling Agreement and related LLU Services. Sub Loop Unbundling (either copper or fibre)
Street Cabinet SPOC	The distributor allowing cross-connection between the feeder cable pairs and the distribution cable pairs. The Single Point Of Contact provided by either Party to the other for the purpose and within the frame of the Unbundling Agreement and related LLU Services.
Technical Information Street Cabinet	Documentation about the technical characteristics related to this RUO and made available to the Operators on POST Technologies' Website. The distributor allowing cross-connection between the feeder cable pairs and the distribution cable pairs.
Unbundling Agreement Technical Information	The agreement between POST Technologies and the concerned Operator, including the schedules and – if relevant – amendments thereto, covering LLU Services and which: has already been executed prior to the entry into force of this RUO and shall be automatically amended thereby, or which will be later on executed for the purpose of and in compliance with this RUO, which shall be an integral part thereof. Documentation about the technical characteristics related to this RUO and made available to the Operators on POST Technologies' Website
VDSL	Very High speed Digital Subscriber Line
VULA	Virtual Unbundled Local Access
Working Days VDSL	Any days of the week in Luxembourg under exclusion of Saturday, Sunday as well as any public, statutory or bank holiday in the Grand-Duchy of Luxembourg. Very High speed Digital Subscriber Line
xDSL Working Days	ADSL1, ADSL2, ADSL2+, VDSL2 and other xDSL when applicable. Any days of the week in Luxembourg under exclusion of Saturday, Sunday as well as any public, statutory or bank holiday in the Grand-Duchy of Luxembourg.
xDSL	ADSL1, ADSL2, ADSL2+, VDSL2 and other xDSL when applicable

Schedule 2. Unbundling Service Description

POST Technologies' LLU Services concern copper and fibre "local loops". The term "local loop" is generic as it concerns full local loops (between MDF/ODF and End Users' premises), ~~and~~ local sub-loops (copper wires between SLCP and End Users' premises) and virtual unbundling (VULA).

2.1 Metallic Path Facility Full Local Loop Unbundling

2.1.1. Description

The Metallic Path Facility (MPF) means a pair of fully metallic continuous unequipped copper wires between POST Technologies' Main Distribution Frame (MDF) at POST Technologies' Local Exchange and the Network Termination Point (NTP) at the End User's premises, at which point the POST Technologies' access network ends.

At the POST Technologies' Local Exchange, the MPFs are terminated at the MDFs. The Operator's access to the metallic wire pairs will be established by connecting tie cables from the MDF to the Handover Distribution Frame (HDF).

The Operator shall gain access to an end-to-end metallic pair in the POST Technologies' access network provided that the required MPF is non-loaded and no active equipment (pair gain system etc.) is present in the relevant circuit. It is further required that the metallic pair circuit is existing and can be provided without new construction of physical metallic pair wires in the network.

The construction of new metallic pair circuits is outside the scope of this RUO and shall be subject to commercial negotiations and is limited to exceptional cases. As POST Technologies is building their new fiber optic network, the metallic path facility will not be available in some regions anymore. A full list of local exchanges where a phase-out of the copper infrastructure is planned is available on POST Technologies' Website.

If buildings are already connected to POST Technologies' FTTH network and equipped with an in-house cabling compatible with the delivery of fibre-based services, POST Technologies will no longer deploy new MPF Services within these buildings. While existing MPF Services may not be cancelled, no request for new or modifications of existing MPF Services will be accepted, if a building is equipped with an active FO-NTP. In case no compatible in-house cabling exists or cannot be deployed due to technical complexities in a multi-dwelling building, the Operator will still have the right to request MPF Services for these buildings and change existing orders for FTTH Fibre Access free of charge into an order for a new MPF Service.

2.1.2. Network Termination Points

2.1.2.1. The MPF service included in the LLU Services covers the 2-wire copper circuit, starting from the MDF at the Local Exchange and terminating ~~at~~ the NTP on the End User's site.

2.1.2.2. The type of NTP depends on the End User's site:

In ~~mMulti-dwellingEnd Users' apartment~~ buildings and buildings for large businesses or corporations, the NTP is the cross-connectable distribution box in the building.

In single-unit houses, the NTP is the first distribution box inside the End User's house.

2.1.2.3. The End User, who has full responsibility for repair and necessary extensions, owns the in-house cabling system up to the different plugs.

2.1.2.4. In the case of Broadband data transmission, the Operator shall guarantee a proper technical termination of the broadband signals having regards to the in-house cabling, in order to avoid reflections or other negative influences impacting the signals of possible other Operators in the building. A centralized splitter is therefore mandatory. The installation shall be done based on best present business practices and knowledge.

2.1.2.5. To allow proper fault analysis for MPF with service migration, POST Technologies agrees to assume testing and measurements to the following endpoints at End User's site:

- If the End User's site is a multi-~~End User's apartmentdwelling~~ building ~~or multi-tenant building (MDU)~~, this will be the first connected telephone plug inside the apartment.
- If the End User's site is a single-unit house, this will be located inside the End User's site, and will be either a telephone plug or a distribution box.
- If the End User's site has a cross-connectable distribution box where multiple pairs are connectable for one End User, this will always be that distribution box.

2.1.3. Boundary Conditions and Prerequisites

2.1.3.1. Co-Location is a prerequisite for the implementation of these LLU Services. Provisioning and maintenance of Co-Location Services will be offered by POST Technologies to the Operator as specified in the applicable RCO.

2.1.3.2. The Operator undertakes to receive from the End User a signed request for each telecommunications service to be provided on a metallic pair in the access network prior to ordering a MPF.

In case of inconsistency, doubts, audit complaint or dispute with the End User, POST Technologies may ask to receive a copy of the above-mentioned request, while the Operator shall keep and archive the said request for the minimum time period specified by applicable Luxembourg laws.

2.1.3.3. When ordering one of the loop types being offered under this RUO, the Operator has to make sure that the equipment used shall be compliant and compatible to POST Technologies' Network.

POST Technologies may require a certificate from the Operator stating that the equipment duly conforms to the equipment requirements specified in the RCO and published on POST Technologies website.

The Operator shall only be allowed to use the indicated loop type for the specified purpose, and shall in no way use any other type of equipment than the one(s) specified in the order form.

2.1.3.4. POST Technologies shall not support customer handling/care services for the Operator's End Users. Requests from Operator's End Users due to inadequate handling of those requests by the said Operator shall be dismissed by POST Technologies, unless otherwise expressly agreed between the Parties.

2.1.3.5. POST Technologies needs and has to ensure the coexistence of all transmission services provided by any Operator on the same cable.

Therefore, the Operator shall comply with the following terms:

- In case POST Technologies suspects that the use of the MPF may lead to not wanted interferences with POST Technologies' Network, POST Technologies shall be entitled to measure the signal over that loop without disturbing the operation of the Operator's network and take all necessary measures to protect the integrity of POST Technologies' network.
- POST Technologies shall reasonably request in writing the right for all measurements that cannot be done without temporary suspension of the Operator's services, while such authorisation shall not be unreasonably withheld or postponed by the Operator.
- In any case of Operator's changes of equipment/technology used, the Operator shall priorly inform POST Technologies thereof in writing in order not to cause any service degradation in POST Technologies' network for other End Users.
- If equipment or network components operated by the Operator for its own use and connected to POST Technologies' network, cause disturbances in POST Technologies' network, the Operator shall be required to disconnect the End User's connection and shall proceed therewith without any delay.
- In order to ensure optimal use of the access network in the context of high-speed signals transmission, POST Technologies is applying cable pair management. These rules take into account the characteristics of the access network cables and the spectral compatibility between signals of different technologies.
- If the Operator finds out that a fault was caused by conditions or circumstances in POST Technologies' network, the Operator shall inform POST Technologies thereof without any delay. The Operator shall be responsible for the accuracy of this information and support consequently any costs related to any unnecessary intervention by POST Technologies.

2.1.3.6. The POST Technologies LLU Services shall only be provided on a line where a NTP exists and is in service in the relevant End User's premises, or where a NTP doesn't exist but is technically possible and the physical address is located in a zone where POST Technologies is still connecting houses based on a copper network. (In this case, the "demande de raccordement souterrain" may be transmitted to the POST Technologies by the Operator, on behalf of the mutual client, following the terms of [Schedule 8](#) ~~Schedule 8~~).

2.1.4. Provisioning and Cessation

The ~~Schedule 3~~ ~~Schedule-3~~ describes the procedures applicable to MPF provisioning, combined provisioning of MPF and number portability and MPF cessation.

2.2. Metallic Path Facility Sub-Loop Unbundling

2.2.1. Description

2.2.1.1. Sub-Loop Unbundling (SLU) means the provision to an Operator of the access to a partial local loop connecting the Network Termination Point (NTP) at the End User's premises to a Sub Loop Connection Point (SLCP) in the local network. Those SLCPs are defined in a separate document published on POST Technologies' Website.

Such SLCPs or new concentration points do exist in buildings and in indoor or outdoor Shelters.

Information concerning existing SLCPs in concentration points is published on POST Technologies' Website.

2.2.1.2. All equipment connected to Sub-Loops shall comply with the specifications defined on POST Technologies' Website.

2.2.2. Network Termination Points

NTPs at the End User's premises are defined in the same way as specified in paragraph ~~2.1.22.1.2~~.

2.2.3. Boundary Conditions And Prerequisites

The conditions and prerequisites defined in ~~2.1.32.1.3~~ shall apply mutatis mutandis to SLU, except that Co-Location is not a prerequisite for SLU services. For the connection of the Operator's equipment, housed in the Operator's own outside shelter, to the SLCP as described in the RCO, an Operator-specific tie cable shall be provisioned by POST Technologies.

2.2.4. Backhaul Connections in the context of SLU

~~The Operator may request a quote for the rental of bBackhaul fibre connections are provided o between the SLCP and the Local Exchange. n a FTTO infrastructure as described in Schedule 3.~~

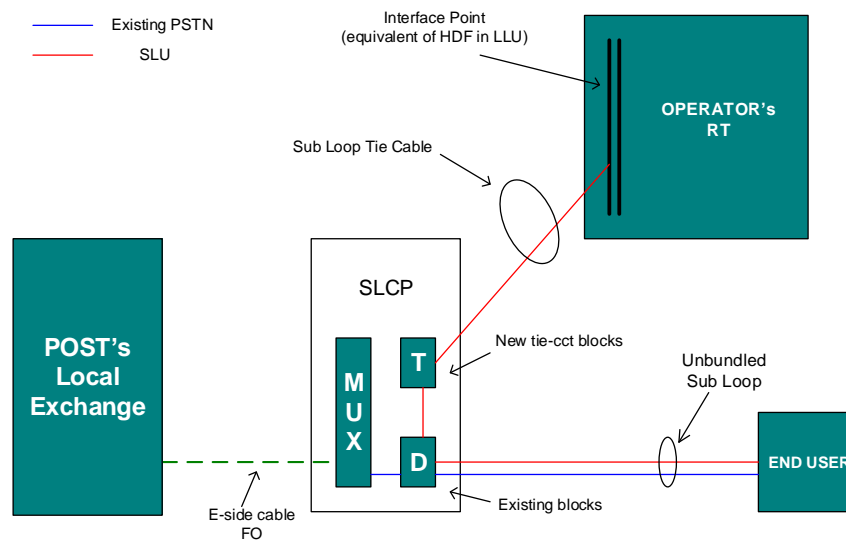

Figure 11 : Backhaul Connection of a Sub-Loop Connection Point (SLCP)

A regularly updated list of the SLCPs without an available copper connection to the MDF (E-side), including their physical addresses, is published on POST Technologies' Website.

2.2.5. Provisioning and Cessation

The Provision and Cessation defined in [2.1.42.1.4](#) shall apply mutatis mutandis to SLU.

2.3. Tie Cables and Rack Connection Facilities

Depending on the Colocation type, Tie Cables and Rack Connection Facilities are required to connect cables terminating at POST Technologies MDF and ODF to the Operator's equipment in its Colocation Space. These services are part of the Colocation Services and their description can be found in the applicable Reference Colocation Offer (RCO).

2.3.1.1. Description

~~At the POST Technologies Local Exchange, the copper wires are terminated in the MDF. The Operator's access to the copper wire will be established with tie cables from the MDF of the Local Exchange to the Operator's Co-Location area in or adjacent to that same POST Technologies' Site.~~

~~The Co-Location Equipment Room may be situated inside POST Technologies' building or in a shelter outside the building.~~

~~The Operator will order the tie cables prior to the request of MPF. The procedure covering forecasts are described in Schedule 3; the ordering process is described in Schedule 3. If, at a certain point in time, no more free wires are available in the tie cables, the specific orders for MPF will be rejected.~~

~~The tie cables will be supplied in increments of 100 pairs. The type of cable provided is twisted~~

~~pair broadband cable.~~

~~2.3.1.2. Boundary conditions and prerequisites~~

~~Co-Location is a prerequisite for the implementation of these LLU Services. As long as an Operator does not have approved Co-Location facilities, no order for tie cables can be executed.~~

~~The Operator shall provide, at its own expenses, in the specified Co-Location area, suitable accommodation for POST Technologies' equipment associated with the tie cables.~~

~~The tie cable will have, associated with it, termination blocks provided by POST Technologies. The termination blocks are installed at the MDF and at the HDF provided by the Operator. The HDF is for the sole use of the Operator within the specified Co-Location area.~~

~~Tie cables for voice band or narrow band data will be terminated on LSA plus connection blocks with a possibility to disconnect or to do intrusive measurement~~

~~All installations shall be done by POST Technologies or by POST Technologies' subcontractors in the most optimised way. The routing of the tie cables shall be at POST Technologies' sole discretion.~~

~~POST Technologies shall be responsible for the installation and maintenance of the cable and termination blocks. The handover point shall be the termination block on the HDF.~~

~~The Operator shall be solely responsible for any loss, theft, destruction of, or damage to POST Technologies' equipment in the accommodation housing the tie cable at the accommodation provided by the Operator, howsoever caused, occurring at any time while such POST Technologies' equipment is so located.~~

~~For normal provisioning, POST Technologies does not need to intervene on the HDF termination blocks. Therefore, the Operator is entitled to lock access to the HDF.~~

~~In case of presumed interference or other problems on the tie cable as described in Schedule 3, POST Technologies may request the Operator to enable temporary access to a locked HDF at no expense for POST Technologies.~~

~~2.3.1.3. Provisioning And Cessation~~

~~The procedure for tie cables provisioning is described in Schedule 3.~~

2.3.2. Tie cables management

~~2.3.2.1. Tie cables shall at all times be filled before a new tie cable is deployed for the provision of additional MPF; the Operator shall be responsible for ensuring this.~~

~~2.3.2.2. The Operator shall therefore submit MPF provisioning for partially filled Tie Cables in preference to empty tie cables.~~

~~2.3.2.3. In case of capacity constraints on the MDF and partially used tie cables, a rearrangement may need to be performed to de-fragment the use of cables and to eliminate gaps within the tie cable pair allocation thus eliminating unused pairs in excess of 50% of active pairs.~~

~~2.3.2.4. This activity will be done in cooperation with the Operator, while POST Technologies will do the rearrangement, pair by pair, at the MDF and the Operator at the HDF.~~

~~2.3.2.5. POST Technologies will bill this rearrangement activity to the Operator.~~

2.4. ~~Fiber~~ **FTTH** Access (**FA**) – Local Loop Unbundling

2.4.1. General description

~~In POST Technologies' point-to-point FTTH network, FTTH~~ The Fibre Access (**FA**) – ~~Local Loop~~ means a single mono-mode fibre between POST Technologies' Optical Distribution Frame (ODF) at POST Technologies' Fibre POP and the Fibre Optical Network Termination Point (FO-NTP), at which point the POST Technologies' FTTH access network ends.

~~In POST Technologies' point-to-multipoint FTTH network, FTTH Fibre Access means a single mono-mode fibre between POST Technologies' Sub-Loop Concentration Point (SLCP) and the Fibre Optical Network Termination Point (FO-NTP), which is connected to a fibre optic splitter installed within the SLCP. Up to 16 FTTH point-to-multipoint fibres will be connected to a single splitter and extended via a backhaul fibre to the Optical Distribution Frame (ODF) inside a Fibre POP within POST Technologies' network.~~

At POST Technologies' Fibre POP, optical fibres are terminated at the ODFs. The Operator's access from Operator's rack to the optical fibres will be established by means of a direct fibre patch between the ODF and the Operator's Rack (Fibre POP type A, also referred to as Area POP) or by means of a fibre connection between the ODF and the Operator's rack through a RCF (Fibre POP type B and C) in the Co-Location Equipment Room or the Co-Location Shelter.

The Operator shall gain access to an end-to-end optical fibre connection within POST Technologies' point-to-point and/or point-to-multipoint FTTH access network. In case of point-to-multipoint fibres, the Operator gains access to the backhaul fibre connected to the splitter within the SLCP.

It is further required that the optical circuit is existing and can be provided without new construction of physical optical cables or splicing in the network (except for the required splicing within the SLCP to connect the existing fibre to the splitter allocated to the Operator).

The construction of new optical circuits is outside the scope of this RUO but a new FO-NTP can be ~~requested~~asked by the Operator (on behalf of the End User) and shall be provided by POST Technologies, under this RUO, if technically feasible and if the physical address is located in a zone already covered by POST Technologies' point-to-point and/or point to multipoint FTTH network.

2.4.2. Network Termination Points

2.4.2.1. The ~~FTTH Fibre Access~~ **FA**-Service covers a single mono-mode fibre circuit, starting ~~either~~ from the ODF at the Fibre POP ~~or at an SLCP~~ and terminating on the FO-NTP at the End User's site.

2.4.2.2. The FO-NTP type depends on the End User's site:

- In Multi-End Users' apartment buildings, the FO-NTP is the cross-connectable distribution box in the building where the fibre optic outdoor cable ends.

- In single-unit houses, the FO-NTP is the first distribution box inside the End User's house where the fibre optic outdoor cable ends.

2.4.2.3. The End User has full responsibility for installation, repair and necessary extensions of the in-house cabling system to the different telephone plugs. Therefore the in-house cabling is private propriety.

It has to be stressed that POST Technologies' responsibility ends at the FO-NTP. No action or measurements will be done by POST Technologies on the in-house cabling neither in case of the installation of a new line nor in case of faults clearance.

2.4.3. Boundary Conditions and Prerequisites

2.4.3.1. Co-Location is a prerequisite for the implementation of these [FTTH Fibre AccessA](#) Services.

Provisioning and maintenance of Co-Location Services will be offered by POST Technologies to the Operator as specified in the applicable RCO.

2.4.3.2. In case of Fibre POPs type B and C, the existence of spare capacity in the RCF is a prerequisite for the implementation of [FTTH Fibre AccessA](#) Services.

2.4.3.3. The Operator undertakes to receive from the End User a signed request for each telecommunications service to be provided on a [FTTH fibreA](#) prior to ordering FA Services.

In case of inconsistency, doubt, audit complaint or dispute with the End User, POST Technologies may ask to receive a copy of the above-mentioned request, while the Operator shall keep and archive the said request for the minimum time period specified by applicable Luxembourg laws.

2.4.3.4. POST Technologies shall not support customer handling/care services for the Operator's End Users. Requests from Operator's End Users due to inadequate handling of those requests by the said Operator shall be dismissed by POST Technologies, unless otherwise expressly agreed between the Parties.

2.4.4. Provisioning and Cessation

The ~~Schedule 3~~ [Schedule 3](#) Procedure describes the procedures applicable to [FTTH Fibre AccessA](#) provisioning and ~~FA~~ cessation.

2.4.5. Technical Specifications of POST Technologies' ~~point-to-point~~ FTTH infrastructure

2.4.5.1. Network

The figure below gives a schematic representation of POST Technologies' [point-to-](#)

point FTTH network for FTTH Fibre Access Services.

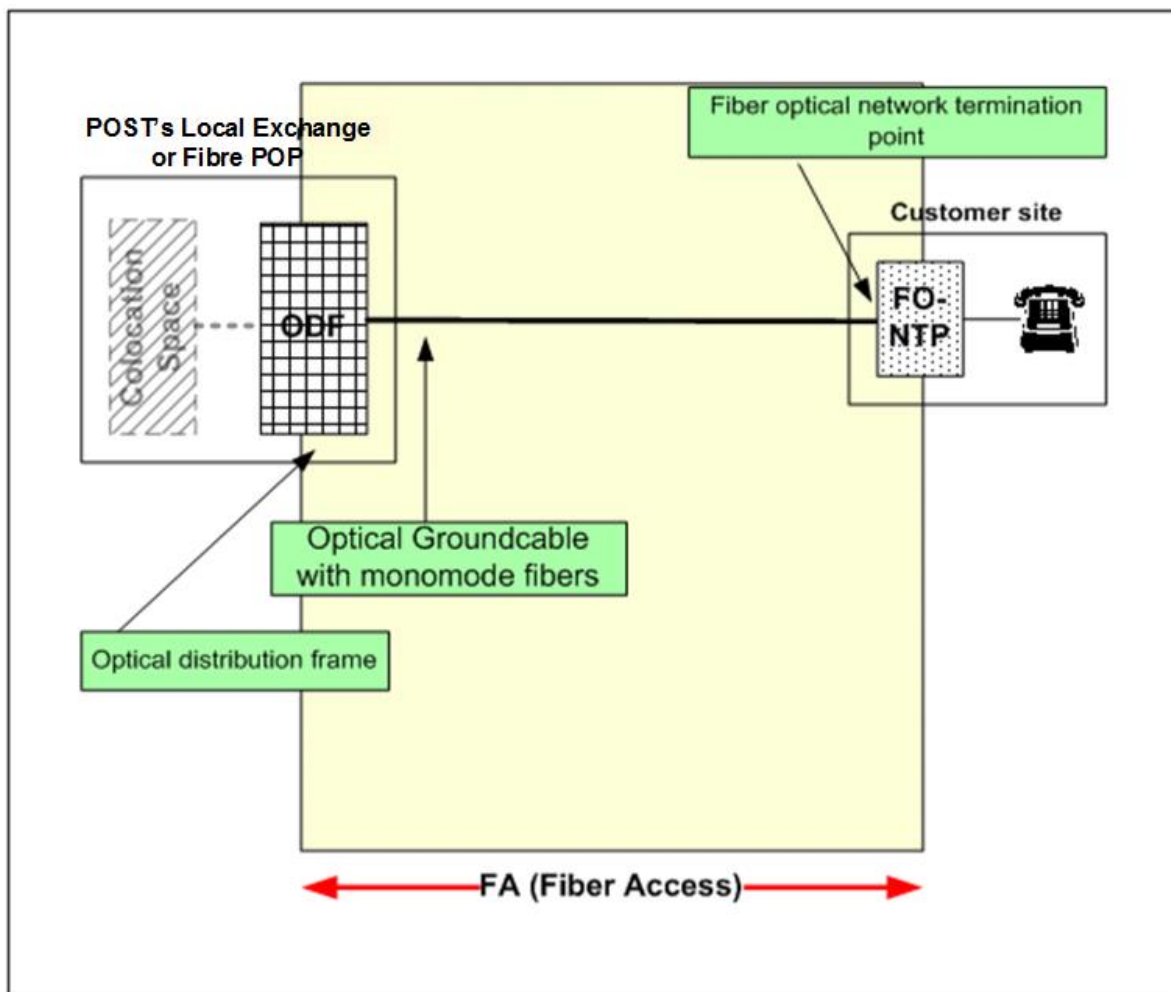

Figure 22 : FTTH Fibre Access (FA) Service in the point-to-point FTTH network

In point-to-multipoint networks there are not enough fibres between the SLCP and the Fibre POP in order to connect each fibre in a 1:1 ratio through to the ODF inside the Fibre POP. Therefore optical splitters are used in a 1:16 ratio in order to connect up to 16 FTTH fibres to one backhaul fibre which connects the SLCP to the Fibre POP. The figure below gives a schematic representation of POST Technologies' point-to-multipoint FTTH network for FTTH Fibre Access Services.

Backhaul connections are provided on a FTTO infrastructure as described in Schedule 3. It has to be noted, that for each 16 ordered fibre access — sub loop unbundling services, the operator receives in relation to Schedule 10, one Backhaul fibre connectivity.

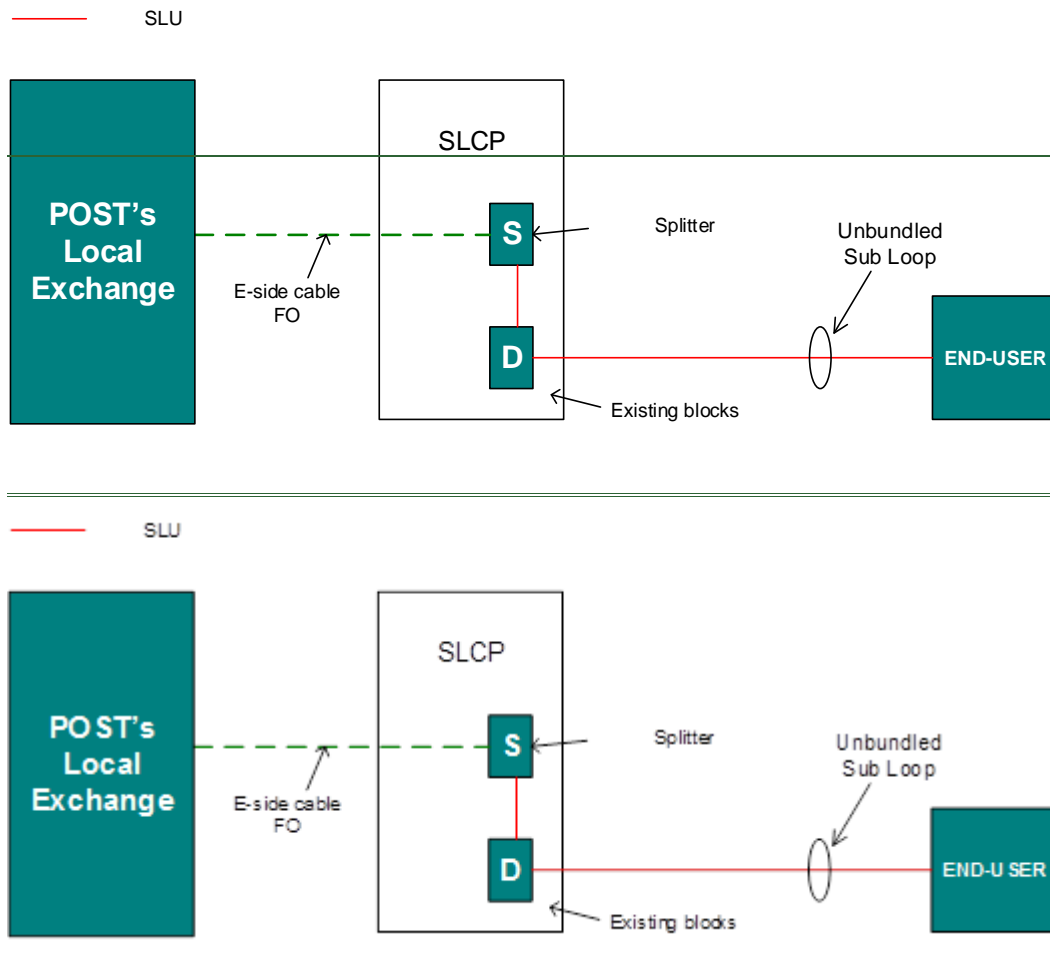

Figure 33 : Backhaul Connection of a Sub-Loop Connection Point (SLCP)

2.4.5.2. Fibre Cable Properties

The optical fibres used are monomode fibres 9/125 μm according to ITU-T G.652D or G.657A. The maximum attenuation is 0,34 dB/km at 1310nm and 0,21 dB/km at 1550nm. The fibres are terminated at the ODF and at the FO-NTP with tuned SC-APC 9° connectors.

~~2.5. Fiber Access (FA) – Sub-Loop Unbundling~~

~~2.5.1. General description~~

~~The Fibre Access (FA) – Sub-Loop means a single mono-mode fibre between POST Technologies' Optical Distribution Frame (ODF) at POST Technologies' SLCP and the Fibre Optical Network Termination Point (FO-~~

~~NTP), at which point the POST Technologies' FTTH access network ends. Those SLCPs are defined in a separate document published on POST Technologies' Website.~~

~~It is further required that the optical circuit is existing and can be provided without new construction of physical optical cables or splicing in the network.~~

~~The construction of new optical circuits is outside the scope of this RUO but a new FO NTP can be asked by the Operator (on behalf of the End User) and shall be provided by POST Technologies, under this RUO, if technically feasible and if the physical address is located in a zone already covered by POST Technologies' point to point and/or point to multipoint FTTH network.~~

~~2.5.2. Network Termination Points~~

~~NTPs at End User's premises are defined in the same way as specified in Schedule 2.~~

~~2.5.3. Boundary Conditions and Prerequisites~~

~~The conditions and prerequisites defined in paragraph 2.4.3 shall apply mutatis mutandis to FA Sub-Loop Services. For the connection of Operator's splitter, housed in the SLCP an Operator-specific tie cable shall be provisioned by POST Technologies.~~

~~2.5.4. Provisioning and Cessation~~

~~The rules specified for the FA service in paragraph 2.4.4 shall apply mutatis mutandis to FA Sub-Loop services.~~

~~2.5.5. Backhaul Connections in the context of a FA Sub-Loop~~

~~Backhaul connections are provided on a FTTO infrastructure as described in Schedule 3. It has to be noted, that for each 16 ordered fibre access sub-loop unbundling services, the operator receives in relation to Schedule 10, one Backhaul fibre connectivity.~~

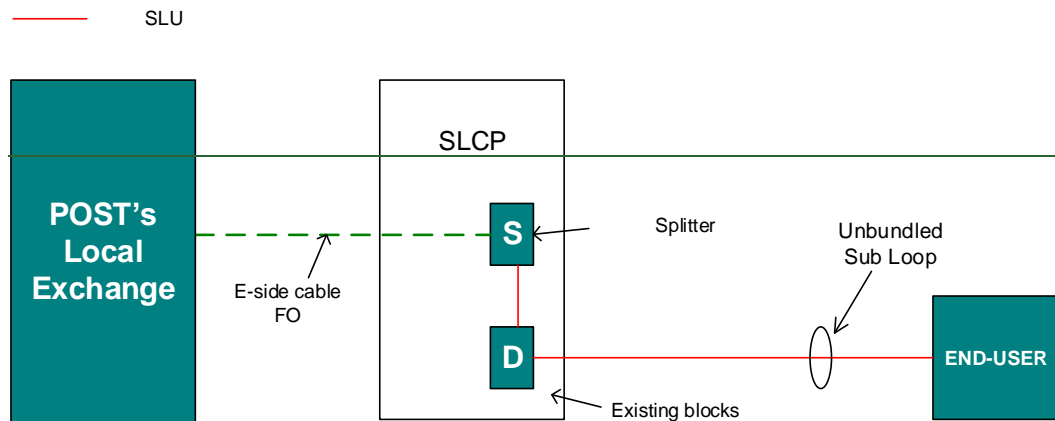

Figure 3 : Backhaul Connection of a Sub-Loop Connection Point (SLCP)

2.5.6. Technical Specifications of POST Technologies' point-to-point FTTH infrastructure

Fibre Cable Properties

The optical fibres used are monomode fibres 9/125 μm according to ITU-T G.652D or G.657A. The maximum attenuation is 0,34 dB/km at 1310nm and 0,21 dB/km at 1550nm. The fibres are terminated at the ODF and at the FO-NTP with tuned SC-APC 90° connectors.

2.6.2.5. Operator Rack Connection

The Operator rack connection physically represents the connection from Operator rack to ODF to grant Operator access to the terminating segment of POST Technologies' point-to-point FTTH infrastructure.

2.6.1.2.5.1. Principles

In case the ODF is located in an Area POP, the Operator rack connection (connection between the ODF and Operator's rack) is done after POST Technologies receives an order for FTTH Fibre Access Services. This means that the Operator rack connection is not a prerequisite as in the case of Fibre POPs type B and C.

2.6.1.1.2.5.1.1. Area POP specificities

As specified before, no dedicated RCF (Rack Connection Facility, also referred to as Tie Cable) is required in case of an Area POP (Fibre POP type A). The Operator rack

connection is the direct fibre optic patch between the ODF and the Operator rack implemented during the FTTH Fibre Access FA-Service provisioning. The patch is provided by POST Technologies and has the following characteristics:

Both ends will be terminated with an SC-APC 9° connector to be connected to the ODF and on the other end to be connected to the Operator's rack. The connector type may be changed by POST Technologies with future technologies.

The fibre patch will be installed by POST Technologies and connected to the ODF. On the Operator side the end of the patch will be available near the Operator rack with sufficient length to allow the Operator to connect the patch to its equipment. The marking on the patch cord shall be done by POST Technologies on site and shall contain the ODF number and the F FTTH Fibre Access A-service number.

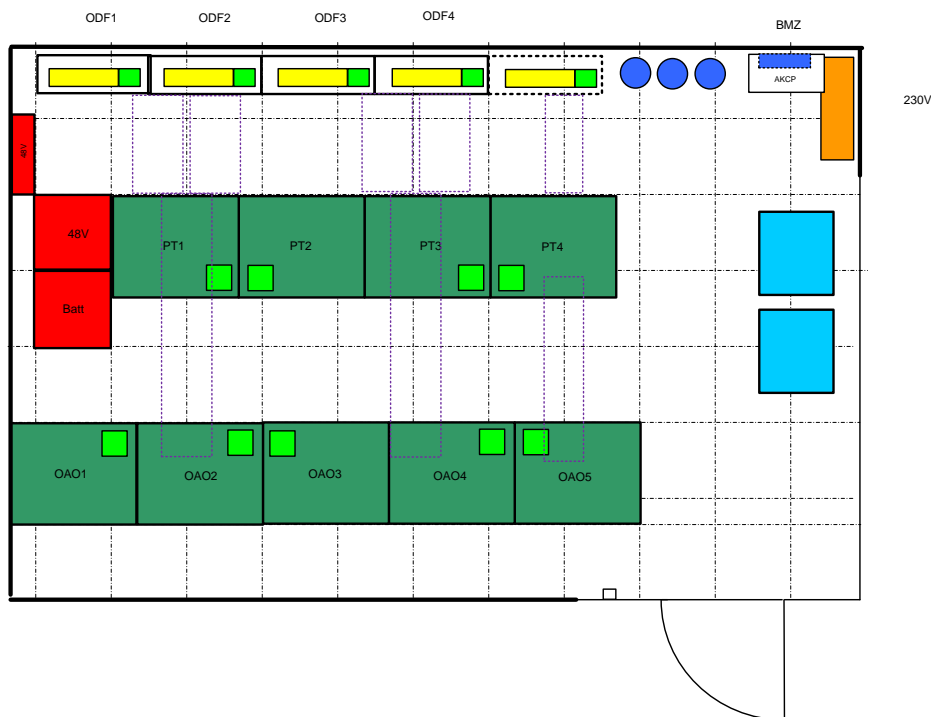

Figure 44 : Typical configuration of an Area POP

Note: Exact configuration might differ for some Area POPs

2.6.1.2.2.5.1.2. Operator rack connection in Fibre POPs type B

In case the ODF is located in a Fibre POP type B (Local Exchange with dedicated Co-Location Equipment Room), the Operator rack connection (connection between the ODF and the Operator's rack) is done by means of a RCF (Rack Connection Facility, also referred to as Tie Cable). This RCF is a prerequisite for the implementation of FTTH Fibre Access FA-Services. The RCF consists of 2 parts: (i) an optical cable between POST Technologies' main ODF and the Co-Location ODF (also referred to hereafter as "FO-VZ") in the Co-Location Equipment Room to be provided and installed by POST Technologies and (ii) a break-out cable of 24 fibres between the

~~FO-VZ in~~ the Co-Location ~~ODFroom~~ and ~~the~~ Operator's racks to be provided, installed and connected to Operator's rack by the Operator.

The RCF will be documented in POST Technologies' cable management database and when Operator requests a new FTTH Fibre Access FA-Service, it will receive the information which fibre of its RCFs has to be used. If, at a certain point in time, no more free fibres are available in the RCFs, the specific orders for FTTH Fibre Access FA will be rejected. In this case, the Operator gets the information that a new RCF needs to be ordered by the Operator. The RCFs have to be installed prior to the request of FTTH Fibre Access FA-Services to be terminated at the ODF of this site.

2.6.1.2.2.5.1.2.1 ODF – FO-VZ part of RCF

POST Technologies will handle the cabling between ODF and FO-VZ in the Co-Location Equipment Room. POST Technologies ensures that upon order of an RCF the necessary fibre connections between ODFs and the FO-VZ are installed.

2.6.1.2.2.5.1.2.2 FO-VZ - Operator rack part of RCF

The Operator provides and installs the break-out cable in a way that one end is close to the FO-VZ installed in the Co-Location Equipment Room. The end of the break-out cable close to the FO-VZ shall have SC-APC 9° connectors and each one of the 24 dropped-out single cable elements on this side must have a length of 2,6m. In a second step, POST Technologies will physically connect the break-out cable to the FO-VZ. The Operator is responsible to physically connect the other side of the break-out cable to equipments installed in its rack.

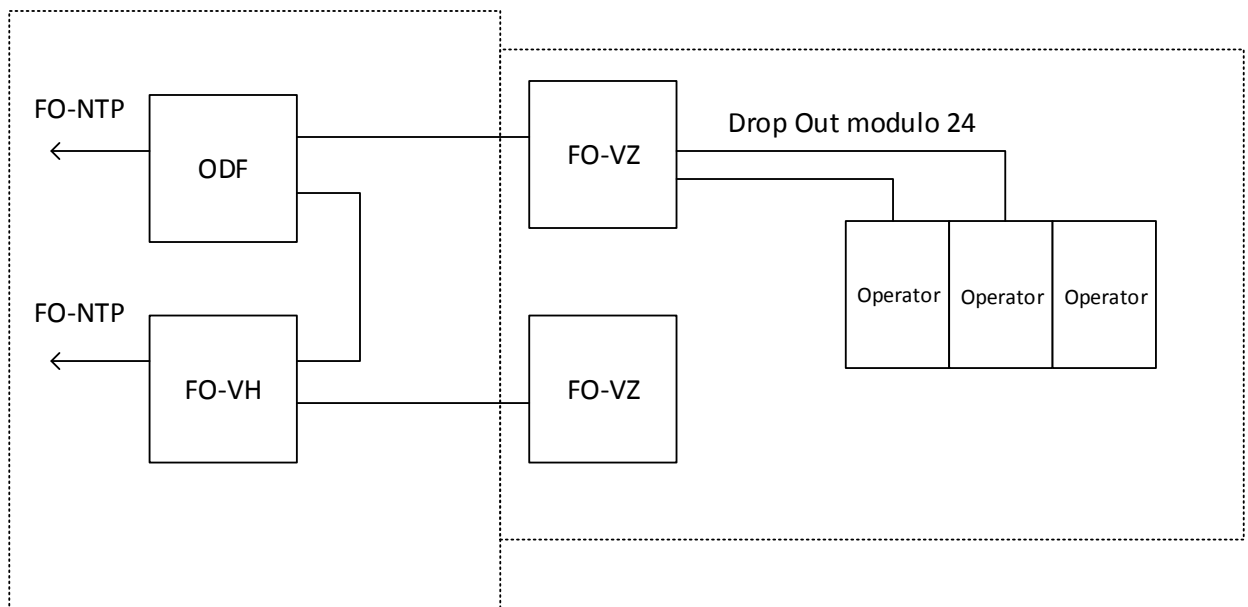

Figure 55 : Rack Connection Facility (RCF)

2.6.1.3.2.5.1.3. Operator Rack Connection in Fibre POP type C

The Operator rack connection between the ODF and Operator's Racks installed in outside shelters in the near vicinity of the POST Technologies technical building is done by means of a RCF, consisting of an optical cable between the ODF and the

outside shelter. POST Technologies provides and installs this optical cable. The termination panel in ODF and the OHDF ([Optical Handover Distribution Frame](#)) in the Operator's outside shelter form an integral part of this RCF. POST Technologies connects both ends of the RCF to ODF and OHDF.

RCFs will be documented in POST Technologies' cable management database and have to be ordered from POST Technologies and installed by POST Technologies prior to the request of [FTTH Fibre Access FA](#)-Services to be terminated at this site.

The patching between OHDF and the Operator's equipment in the outside shelter is the sole responsibility of the Operator.

2.6.2.2.5.2. Boundary conditions and prerequisites

Co-Location as defined in the applicable RCO is a prerequisite for the implementation of Operator rack connections. As long as an Operator does not have approved Co-Location facilities, no order for Operator rack connections can be accepted.

POST Technologies shall be responsible for the maintenance of the cable and termination panels in the ODF. The handover point shall be the Operator rack side end of the optical patch in case of an Area POP or a given fibre on Operator rack side of the break-out cable as defined in [2.5.1.22.5.1.22.6.1.2](#) or a given port on the OHDF in Operator's rack in an outdoor shelter as defined in [2.5.1.32.5.1.32.6.1.3](#).

The Operator shall be solely responsible for any loss, theft, destruction of, or damage to POST Technologies' equipment in the accommodation housing the RCF at the accommodation provided by the Operator, howsoever caused, occurring at any time while such POST Technologies' equipment is so located.

In case of normal provisioning, POST Technologies does not need to intervene in the Operator's rack. Therefore, the Operator is entitled to lock access to its rack.

In case of problems arising on the RCF, POST Technologies may request the Operator to enable temporary access to a locked rack where the RCF is terminated at no expense for POST Technologies.

2.5.3. Provisioning

2.6.3.

The procedure for Operator Rack Connection provisioning is described in [Schedule 3Schedule 3](#).

2.6. VULA Services

2.6.1. The Need for a Substitute Product

[The new FTTH network that POST Technologies currently deploys and for which a large number of Fibre POPs have been built is based on a point-to-point \(P2P\) topology, meaning that each](#)

connected fibre within an End User site will be directly connected to a Fibre POP and available for unbundling services at said Fibre POP.

Parts of POST Technologies fibre network, however, is still built on infrastructure which already existed at the time when the roll-out for a nationwide P2P FTTH network started. In order to activate this existing fibre infrastructure as quickly as possible and give End Users access to high speed broadband services, these existing infrastructures had to be connected in a point-to-multipoint (P2MP) topology. Existing fibre cables coming from End User sites were terminated in street cabinets, which were not yet equipped with sufficient backhaul fibre capacity to allow a 1:1 connection of each End User fibre through to the Local Exchange.

As the expansion of the P2P FTTH network continues, it will become possible to convert existing P2MP networks into a P2P topology and connect those fibres to the new purpose-built Fibre POPs. This conversion into P2P topologies of existing P2MP networks is carried out in parallel with the deployment of new FTTH networks and also depends on its progress. As P2P is the target topology, which allows for easy unbundling of fibre infrastructures, further investments into building new adjacent street cabinets or expanding existing ones in order to temporarily enable fibre unbundling in street cabinets, where current space and backhaul capacity as well as legacy fibre termination technologies do not allow for straightforward unbundling of these P2MP fibres, need to be considered as economically unacceptable and would also slow down the progression of the FTTH P2P roll-out by requiring additional resources for these transformations.

Therefore an additional product – VULA (**V**irtual **U**nbundled **L**ocal **A**ccess) has been defined and is made available to all Operators on the existing P2MP fiber infrastructure.

2.6.2. Service Description

The VULA Service (**V**irtual **U**nbundled **L**ocal **A**ccess) is a broadband service which is provided as a substitute product for the physical unbundling of a P2MP fibre.

This VULA Service allows the Operator to connect to POST Technologies' GPON access networks and offer value-added broadband services to its customers by implementing its own service access profiles adapted to the specific needs of its End Users.

The VULA Service is made up of two components :

- (i) The Access component, from the ONT (Optical Network Terminal) at the End User's premises to the OLT (Optical Line Terminal), which serves as the termination point for all VULA circuits which will be built using the GPON technology
- (ii) The VULA Interconnection component, an Ethernet interface in the OLT which serves as the PoI (Point of Interconnection) between POST Technologies and the Operator

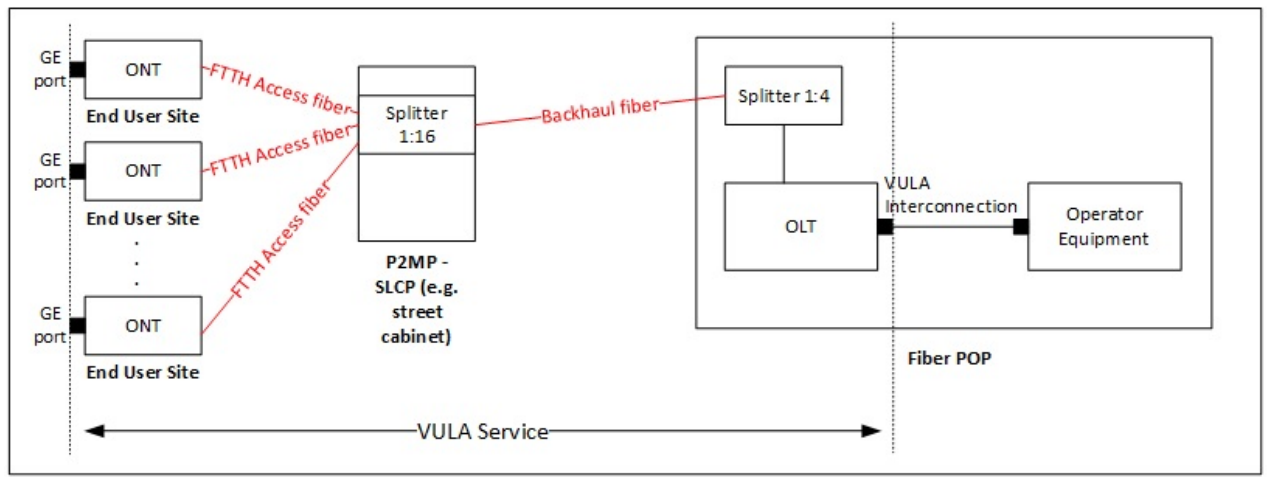

VULA circuits will be based on an optical GPON infrastructure, the termination point and demarcation point for the VULA Service at the End User's premises is the ONT installed by POST Technologies. The ONT offers a Gigabit Ethernet interface (RJ45) according to IEEE 802.3ab.

The currently deployed GPON technology delivers 2,5 Gbps downstream and 1,25 Gbps upstream on a single port on the OLT which will be shared by all the ONTs connected through splitters to this same OLT port. POST Technologies currently uses a splitter ratio of max. 1:64 per OLT port (in two steps – 1:16 in the street cabinets and 1:4 in the Fibre POPs). Bandwidth profiles for the VULA Service will currently be limited to 1 Gbps down/500 Mbps up. Future deployment of new PON technologies in the access network of POST Technologies will allow to increase capacity and offer additional VULA profiles with higher bandwidths which will then be added to an amended reference offer.

As the VULA Service acts as a substitute for fibre unbundling, it should be provided in a way which comes closest to the one of an unbundled fibre, offering transparent connections with no unreasonable limitations to the service provided. However, in order to allow for capacity planning and guarantee a low contention ratio in this shared environment, bandwidth profiles closest to the ones actually sold to and used by the End User need to be defined to enable POST Technologies to manage the contention ratio by reducing, if required, the applicable splitter factor in order to comply with net neutrality requirements and guarantee values for the announced normally available speeds.

POST Technologies will propose multiple bandwidth profiles to the Operator of which he will choose the ones most adapted to his needs. The Operator will act in good faith and order the profile matching most closely the requirements of the product purchased by the End User.

<u>Profile</u>	<u>VULA 100</u>	<u>VULA 200</u>	<u>VULA 300</u>	<u>VULA 400</u>	<u>VULA 500</u>	<u>VULA 600</u>	<u>VULA 700</u>	<u>VULA 800</u>	<u>VULA 900</u>	<u>VULA 1000</u>
<u>Downstream (Mbps)</u>	100	200	300	400	500	600	700	800	900	1000
<u>Upstream (Mbps)</u>	50	100	150	200	250	300	350	400	450	500

The VULA Service is transparent to all Layer 3 protocols. The maximum MTU size is 1548 bytes. Layer 2 and Layer 3 QoS markings configured by the Operator will be transmitted between the End User and the OLT in a transparent way without any alterations.

The traffic of all VULA Services terminating on the same OLT will be passed on to the Operator via the VULA Interconnection interface. The standard interface provided will be one 10 Gigabit Ethernet interface (10GBase-LR LAN PHY 1310 nm) per OLT. Optionally, if required, the Operator might also ask for the deployment of a 100 Gigabit Ethernet interface (100GBase-LR4, 1310 nm).

All the VULA Services will be delivered in a Mono-VC configuration allowing for a single VLAN to be configured at Interconnection level. The same VLAN will be used on all VULA Interconnections configured for a single Operator throughout all the Fibre POPs in which the Operator has opted for the VULA Service. If an Operator has also subscribed to the ROB (Reference Offer for Broadband Services) and purchases Bitstream Services from POST Technologies, the VLAN-ID used for the VULA Services must be different from the ones already implemented for the Bitstream Services.

No volume-based billing will be applied in regard to the VULA Services.

Operators requiring the support of Multicast traffic, mostly used for optimizing capacity usage when distributing IPTV services across the network, may choose between two solutions :

- (i) Implementing Multicast support on the VULA Interconnection or
- (ii) Implementing routing of Multicast traffic to the central Multicast RHD interconnection already used in the context of Bitstream services

In case of choosing the first option, a tailor-made offer will be provided for the implementation of the Multicast configuration according to the Operator's requirements. In case of choosing the second option, the existing conditions for the Multicast option as defined ~~for~~within the Bitstream product will apply to VULA as well.

2.7. Fibre-To-The-Office (FTTO) Services

2.7.1. Service Description

The Fibre-To-The-Office (FTTO) Service means a single mono-mode fibre between POST Technologies' Optical Distribution Frame (ODF) at POST Technologies' Local Exchange and the Fibre Optical Network Termination Point (FO-NTP), at which point the POST Technologies' FTTO network ends.

POST Technologies' Fibre to the Office Access Network is a dedicated fibre optic network specially designed to meet the expectations of professional customers. Due to its design, repair times are far lower than for ordinary FTTH Networks.

At POST Technologies' Local Exchange, optical fibres are terminated at the ODFs. The Operator's access from the Operator's rack to the optical fibres will be established by means of a fibre connection between the ODF and the Operator's rack through an Operator Rack Connection depending on the type of the Fibre POP-RCF.

The Operator shall gain access to an end-to-end optical fibre within POST Technologies' point-to-

point FTTO access network.

As the technical feasibility check is done on a case by case basis, it could be that some civil works have to be carried out in order to deliver the circuit. The Operator will thus receive for each request of a FTTO Service a tailor-made offer.

2.7.2. Network Termination Points

2.7.2.1. The FTTO Service covers a single mono-mode fibre circuit, starting from the ODF at a Local Exchange and terminating on the FO-NTP at the End User's site. From the ODF at the Local Exchange, the service will be prolonged via internal Tie cable to the Operator's Rack.

2.7.2.1. Some Local Exchanges terminating FTTO cables will be closed in the course of the POST Technologies' copper phase-out program. Those FTTO cables will then be terminated in one of the Fibre POP's built for the FTTH network and mostly located in the vicinity of the Local Exchange. In such a case, FTTO fibres terminating at the Local Exchange may also be extended to the Fibre POP in which the FTTO cables will terminate after the Local Exchange has been closed. The list of Local Exchanges and related Fibre POPs will be published on POST Technologies' Website.

2.7.2.2. The FO-NTP type depends on the End User's site:

- In multi-dwelling units like apartment buildings or in industrial buildings, the FO-NTP is the cross-connectable distribution box in the building, where the fibre optic outdoor cable ends. In the case where multiple FO-NTP exist for one customer side, the Operator has to specify the desired FO-NTP.
- In single-unit houses, the FO-NTP is the first distribution box inside the End User's house where the fibre optic outdoor cable ends.

2.7.2.3. The End User has full responsibility for installation, repair and necessary extensions of the in-house cabling system to the different telephone plugs. Therefore the in-house cabling is private propriety.

It has to be stressed that POST Technologies' responsibility ends at the FO-NTP. No action or measurements will be done by POST Technologies on the in-house cabling neither in case of the installation of a new line nor in case of faults clearance.

2.7.3. Boundary Conditions and Prerequisites

2.7.3.1. Co-Location is a prerequisite for the implementation of these FTTO Services. Provisioning and maintenance of Co-Location Services will be offered by POST Technologies to the Operator as specified in the applicable RCO.

2.7.3.2. The existence of spare capacity in RCF is a prerequisite for the implementation of FTTO Services.

2.7.3.3. The Operator undertakes to receive from the End User a signed request for each telecommunications service to be provided on a FTTO fibre prior to ordering a FTTO Services.

In case of inconsistency, doubt, audit complaint or dispute with the End User, POST Technologies may ask to receive a copy of the above-mentioned request, while the Operator shall keep and archive the said request for the minimum time period specified by applicable Luxembourg laws.

2.7.3.4. POST Technologies shall not support customer handling/care services for the Operator's End Users. Requests from Operator's End Users due to inadequate handling of those requests by the said Operator shall be dismissed by POST Technologies, unless otherwise expressly agreed between the Parties.

2.7.4. Provisioning and Cessation

The ~~Schedule 3~~ Procedure describes the procedures applicable to FTTO provisioning and FTTO cessation.

2.7.5. Technical Specifications of POST Technologies' point-to-point FTTO infrastructure

Fibre Cable Properties

The optical fibres used are monomode fibres 9/125 µm according to ITU-T G.652D or G.657A. The maximum attenuation is 0,34 dB/km at 1310nm and 0,21 dB/km at 1550nm. The fibres are terminated at the ODF and at the FO-NTP with tuned SC-APC 9° connectors.

2.7.6. Exceptions regarding POST Technologies' FTTO infrastructure

While the FTTO access network has been designed to mainly connect office, administrative and industrial buildings, in some exceptional cases existing FTTO cables have also been used to connect nearby residential buildings while no FTTH project had reached the immediate deployment phase in that area. In this case these fibres, which may be part of POST Technologies' FTTO access network, will be offered at the same financial conditions as the FTTH Fiber Access Services in the nearest connected Fibre POP. The available fibres will therefore be listed in the files published on POST Technologies' Website specifying all addresses eligible for FTTH Fiber Access Services.

All free fibres in single-family homes connected in this way will be available for unbundling purposes to the Operators. As the tailor-made FTTO access network of POST Technologies often offers a lesser density in multi-dwelling units which may not be sufficient to connect each unit or apartment with a dedicated access fibre, a few restrictions have been defined in order to allow every Operator to have access to regulated wholesale broadband products in these buildings :

- For every subset of 16 units in such multi-dwelling buildings, POST Technologies will reserve one fibre to enable the non-discriminatory provision of broadband services (e.g. Bitstream Services as specified in the ROB reference offer) to any Operator. This fibre will not be available for unbundling purposes.
- POST Technologies will reserve a maximum of 2 fibres for maintenance issues (e.g. fibre cut) in order to troubleshoot existing active services (incl. Operator's Unbundling services). These fibres will not be available for unbundling purposes.

The following example is used to give a better understanding of these allocation rules.

Residential multi-dwelling building consisting of 36 units, but only connected via 8 fibres to POST Technologies' FTTO access network :

- 3 fibres will be reserved for broadband services
- 2 fibres will be reserved for maintenance purposes
- 3 fibres will be freely available for FTTH Fibre Access Services.

~~2.8. Duct Sharing Service (DSS)~~

~~2.8.1. Service Description~~

~~The Wholesale Duct Sharing Service offered by POST Technologies grants the Operator physical access to POST Technologies' underground infrastructure such as ducts and sub-ducts. This enables an Operator to lay their own fibre or copper cable and provide telecommunications services to its End Users.~~

~~2.8.1.1. Types of offered ducts~~

~~The following lines are offered in the DSS:~~

- ~~Duct with inner diameter 32mm/26mm — External/Internal variation: +/- 2mm~~

- ~~Micro Tube with inner diameter 14mm/10mm – External/Internal variation: $\pm 0.1\text{mm}$~~

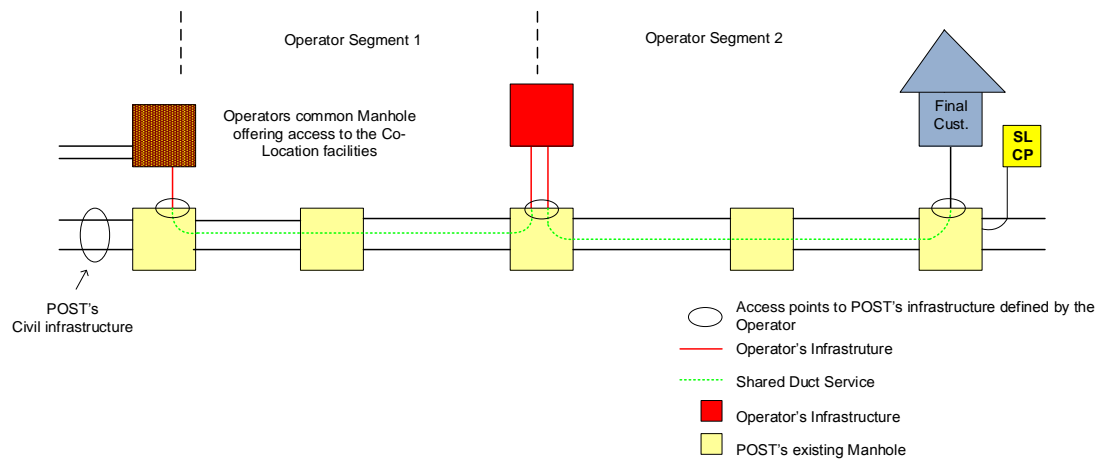

Figure 6 : Components of the Duct Sharing Service

The ducts may be used for the installation of cables/micro-cables or the installation of sub-ducts or micro-tubes. Once an Operator has contracted the DSS, they have full access of the duct allocated to them and they are free to use it as they like within the framework of this RUO and in respect of the technical constraints as specified on POST Technologies' Website.

It is to be noted that a link between two endpoints can only be made in a continuous way, fragmentations are not permitted. The duct is connected between two POST Technologies chambers and is equipped with a gear that enables pulling through the ducts $> 26\text{mm}$.

Generally the chambers of the existing network are either manholes accessible by a ladder with the following dimensions $> 2,0\text{m} \times 1,5\text{m} \times 2,0\text{m}$ (length X width X depth) or chambers with the following dimensions $\leq 1,5\text{m} \times 0,75\text{m} \times 1,3\text{m}$ (length x width x depth)

Due to limited availability of some ducts in some cases, the requested connection cannot be offered for the requested duct diameter and will be adapted to the availability of lines of existing routes.

The installation length of the cables, sub-ducts or micro-tubes depends on the bending angle of the routes and the situation of the ducts has to be considered on a case to case basis.

2.8.1.2. Availability of ducts

It has to be noted that due to maintenance, safety and technical reasons, POST Technologies also requires unoccupied ducts that cannot be taken into account for the duct sharing services. The general rule is POST Technologies requiring 20% unoccupied ducts for normal ducts laid in sand pipes and in concrete pipes. In any case, at least one (1) duct shall be kept vacant as a maintenance duct and as an alternative to any damages one(s).

Sharing shall be based on practicability, technical feasibility and availability. However there

might be smaller ducts available than the ones requested.

However, for the Operator, reservations of ducts are not possible. If for any reason the requested trench route is not available anymore by the time a formal order has been submitted by the Operator, a new analysis needs to be completed before offering the Operator an alternative route to avoid congestion and bottlenecks (rod, rope test)

2.8.2- Availability of ducts

The availability of a duct for a requested connection can take 4 different scenarios:

- immediately available
- Available with civil works or preliminary installations
- Available with preliminary installations
- not available (Alternatively a dark fiber connection may be provided upon request)

The availability date may vary depending on the case. However unexpected occurrences during the period of analysis will extend the availability date. Information related thereto shall be transmitted to the Operator indicating the cause and an expected date of availability.

In case two Operators ask for the same duct route in a situation where availability of ducts is limited, the orders will be processed on a 'first come – first served' basis.

The DSS offer shall be expressly limited to the availability of existing spare capacity in POST Technologies' Network. POST Technologies shall not be responsible for expanding, modifying and/or conditioning in any way POST Technologies Infrastructure to provide DSS to other Operators, and POST Technologies shall not be obliged thereto.

POST Technologies will deploy its best efforts to keep the response time of 95% of the survey requests (Tariffs Schedule 10) within 3 weeks' time. POST Technologies' response will include information about the type and scope of the works to be completed (if applicable) before the operator gets access to the duct requested as well as an estimation of the costs and an estimation of the time of completion of the order.

However, for ducts laid in sand there is no guarantee for availability and quality during the quoting phase as some ducts might be damaged and will have to be repaired in order for the operator to be given access. The repair costs pertaining to that particular duct service request will be charged to the operator.

2.8.3- Maintenance

Every intervention in the aim of inspection, maintenance or for replacing cables, micro tubes of a duct under a DSS contract, must be requested to POST Technologies at least 10 days in advance, in order to schedule the monitoring of the related works.

For the inspection or maintenance of the cables or micro tubes of a duct under a DSS contract, the conditions under paragraph 3.8 are to be observed.

When POST Technologies has planned installation works or maintenance works on the same segment for the period requested by an Operator, the Operator's requested work has to be postponed in order not to interfere with POST Technologies' works.

~~2.8.4. Cessation~~

~~In case of termination of the lease of one section, the duct must be in its initial condition in respect of the conditions under paragraph 3.8.~~

~~The POST Technologies chambers with an interconnection to those of the Operator need to be in their initial condition.~~

~~POST Technologies technicians need to be informed at least ten (10) Working Days in advance, in order to schedule monitoring of the related work.~~

~~2.8.5. Non-compliance of facilities~~

~~In case of non-compliance of the facilities following the instructions from paragraph 3.8, POST Technologies will ask the Operator to become compliant within fifteen (15) Working Days.~~

~~If the Operator has failed to bring into compliance the equipment (joints, fibre closures, cables, micro-tubes) or the network facilities after the said period, POST Technologies will proceed to bringing into compliance the network facilities. The cost of services incurred by this will be charged to the Operator.~~

~~2.8.6. Damages~~

~~POST Technologies shall not be liable in case of force majeure events or where the installation of the Operator will be damaged by vandalism or by a third party.~~

~~Notwithstanding article 1.9.5., if an installation of POST Technologies is damaged during the execution of works, the costs for the repair of facilities and the financial consequences of POST Technologies' operational loss or of another operator, will be at the cost of the Operator.~~

~~2.8.7. Terms and conditions~~

~~DSS shall be provided for a minimum one (1) year lease period. After expiry of this 1st year, the Operator may cancel the DSS upon a one (1) month prior written notice.~~

~~The applicable tariffs are specified in Schedule 10.~~

~~In case the existing infrastructures (being either POST Technologies' and/or Operator's ones) have to be moved or ceased in whole or in part due to external constraints or to POST Technologies' decision to cease a given duct segment, the Operator shall bear the costs related to the changes on its infrastructure.~~

~~In any such case, POST Technologies shall not be liable nor be held liable to pay any compensation or indemnity to the Operator.~~

~~2.8.8. Access to Area POPs~~

~~Each half rack of the Co-Location cabinets inside the Area POP buildings is connected to the Co-Location chambers through two micro-tubes of a diameter of 14mm/10mm.~~

~~The connections between the POP's can only be achieved by micro-cables compatible with the micro-tube 14mm/10mm.~~

~~The micro-tubes are marked in the Co-Location chambers and in the Co-Location cabinets.~~

The Operator or its subcontractor must proceed to:

- the extension of the micro tubes in the Co-Location chamber with a suitable connector.
- make sure the duct in the POST chamber connected to his own chamber is sealed by installing TDUX inflatable duct seals.
- to the replacement of the protective cap of the micro tube by a single line seal guaranteeing the cables/micro tubes are sealed. The sealing sleeve is attached to the micro tube in the Co-Location cabinet.
- to the installation of the micro cable in the micro tube.

~~2.8.9.~~ Access to the Co-Location Equipment Room at the Local Exchange

~~2.8.9.1.~~ Connection with cables

The Co-Location Equipment Room inside the Local Exchange building is connected to the Co-Location chamber with micro tubes with a diameter of 14mm/10mm. The connection to the Co-Location Equipment Room can only be achieved by a micro cable compatible with the micro tube of 14mm/10mm.

The Operator or its subcontractor must proceed to:

- the extension of the micro tubes in the Co-Location chamber with a suitable connector.
- make sure the duct in the POST chamber connected to his own chamber is sealed by installing TDUX inflatable duct seals.
- installing a single line seal guaranteeing the cables/micro tubes are sealed.
- the installation of the micro cable in the micro tube.

~~2.8.9.2.~~ Connection with standard fiber optic cables

When the Co-Location chamber is linked to the Co-Location Equipment Room through tubes of 40mm/50mm, the installation work of the cables leaving the Co-Location chamber to the Co-Location Equipment Room are to be carried out by the Operator or its subcontractor.

In case there is no separate connection between the Co-Location chamber and the Co-Location Equipment Room, the cable will be installed by POST Technologies and will be charged to the Operator accordingly.

2.8. Service Termination

~~2.9.~~

In case of a network migration that causes POST Technologies to abandon existing infrastructures, close existing sites (e.g. Local Exchanges, street cabinets) and to terminate the delivery of existing Unbundling Services delivered via these sites and specific infrastructures, POST Technologies will notify the concerned Operators one (1) year in advance in case of a site where no Operator is

present and five (5) years in advance in case of sites where an Operator is present. The list of the concerned sites is published on POST Technologies' Website and is updated regularly. It is the responsibility of the Operator to regularly consult POST Technologies' Website in this respect.

Schedule 3. Planning, Ordering and Provisioning

3.1. Coordination between parties

- POST Technologies shall put into place the required organisation in order to manage provisioning of Metallic Path Facility Services, FTTH Fibre Access Services, FTTO Fibre Access Services and VULA~~Duct Sharing~~ Services in POST Technologies' network. A single point of contact handling questions regarding the operational management of Unbundling ~~and Duct Sharing~~ Services will be available to the Operator. This single point of contact will be accessible during Business Hours.
- The Operator undertakes to contact only the POST Technologies single point of contact as specified here above and to provide its own single point of contact for the management of LLU ~~and DS~~ Services, including for questions regarding operational matters.
- POST Technologies' and the Operator's respective single points of contact in relation to this RUO and to the provision of the LLU ~~and DS~~ Services are or, as the case may be, will be specified in the concerned Unbundling Agreement.

3.2. Preliminary exchange of information

POST Technologies will provide to the Operator as soon as reasonably practicable, but not later than five (5) working days~~T51 (timeframe as defined in Schedule 11 - Parameter Schedule)~~ from the date of signature of the non-disclosure agreement for the LLU Services a web login and password for the protected area of POST Technologies' Website to enable the Operator to view:

- ~~The~~ location of MDF or ODF sites,
- ~~A module to find~~ for each postal address the corresponding MDF, SLCP or ODF sites,
- for each postal address connected by FTTH fibre whether these fibres are part of the point-to-point or point-to-multipoint FTTH network and whether the unbundling of the point-to-multipoint fibre is technically feasible or if local access can only be provided via a VULA Service,
- migration plans for the transformation of point-to-multipoint fibre networks into point-to-point networks, i.e. planned dates for SLCP conversion as well as the Fibre POP the fibres will be connected to after the conversion
- ~~A module to find~~ for each service number if the current route is on fibre or copper and, if so, an indication regarding the length of the copper access line,

- ~~F~~for each MDF or ODF Site the type of Co-Location foreseen and the actual status of deployed Co-Location at each location.

The data is provided for the sole purpose of enabling the Operator to consider whether to request services from POST Technologies pursuant to this offer.

3.3. Electronic Information exchange

Except for the ~~DSS and~~ FTTO Fibre Access Services, the exchange of ordering information shall be exclusively done by means of electronic messaging transfer ~~of XML files~~ via Web service ~~in SOAP (Simple Object Access Protocol) format~~.

To be accepted, the structure of the files transmitted shall comply with POST Technologies' specifications and instructions. For this purpose, a complete documentation describing the Web service ~~/ SOAP~~ interface and the procedures for message exchange between an Operator and POST Technologies in relation to LLU Services will be published and timely updated as appropriate on POST Technologies' Website.

Before the first data transmission can take place, the Operator has to perform transmission tests with POST Technologies. A period of maximum twenty (20) working days~~T52~~ is foreseen between the Operator's declaration of its interest in LLU Services and the first file to be accepted.

3.4. Forecasting

Providing new MPF, FTTHA, FTTO or VULADS Services to Operators is a very labour intensive activity. The volume of activity depends mainly on the commercial activity of the different Operators without any direct influence of POST Technologies. To allow proper planning of POST Technologies' production capacity and of its work force allocation as well as to respond to the demand within the indicated time limits and to avoid bottlenecks, an accurate forecasting from the historical data of the systems used by POST Technologies and in some cases from concerned Operators of the required provisioning is essential.

- 3.4.1.1. MPF Services delivered as provision type « Swap Express » (see paragraph ~~3.5.33.5.33.7.3~~) will be realized within a time frame D+3 and D+7 after the positive survey response sent by POST Technologies. No appointment has to be taken on the booking manager system. In principle these lines are not covered by the following forecast rules. Nevertheless, to allow POST Technologies to respect the above mentioned delays, the Operator should inform POST Technologies in advance if the quantity for a given period exceeds by more than 30% (i.e. in case a new Co-Location site is taken in service by the Operator) the average number of orders placed during the last 3 months period.

3.4.1.2. To dimension its work staff, POST Technologies will use a rolling forecast based on the orders received via the online booking manager system during the last 3 months period. No committed forecasts have to be provided by the Operator. POST Technologies will respect the installation time as specified in [this RUO Schedule 11](#) if the deviation of the aforementioned rolling forecast is less than 10%.

3.4.1.3. In case an Operator foresees a substantial increase of MPF, [FATTH](#), FTTO or [VULADSS](#) orders, POST Technologies will do every possible effort to respect the installation time as specified in [this RUO Schedule 11](#) by increasing the necessary workforce as far as the Operator informs POST Technologies by mail hereof at least 3 months in advance.

~~3.4.1.4. During the first six (6) months after the Operator has signed the Unbundling Agreement it will not be possible to use rolling forecasts. During this phase POST Technologies will accept up to 20 orders per month per Operator.~~

~~3.4.1.4. In case an Operator foresees a higher number of orders during the initial phase, POST Technologies will do every possible effort to respect the installation time as specified in [this RUO Schedule 11](#).~~

3.5. Provisioning of Operator Rack connections

3.5.1. General

Each order for an RCF to be passed by the Operator for a given Fibre POP shall be done according to these rules:

- ~~• Forecasts and ordering shall be done by the Operator per Local Exchange.~~
- ~~• All Forecasts and firm orders shall be submitted by email to ordering.technologies@post.lu.~~
- ~~• Irrespective of the terms and conditions stated below, POST Technologies reserves the right to reject any Forecasts for a given Local Exchange in case the volumes requested by the Operator for the concerned Local Exchange in the said Forecasts are not in line with reasonable market demands.~~
- ~~• Subject to priority agreed forecasts, POST Technologies shall make reasonable endeavours to provide the ordered internal tie cables within T30 to the Operator.~~

~~3.5.1.1. Specificities for an Area POP~~

~~As described in 2.6.1.1, no Operator rack connections are needed prior to ordering a FA Service.~~

~~3.5.1.2. Operator rack connection in a Co-Location Equipment Room~~

~~In case of a Co-Location Equipment Room, the Operator has to order and install RCF, as specified in paragraph 2.6.1.2.~~

~~The Operator rack connection consists of 2 parts:~~

~~3.5.1.2.1 ODF — FO-VZ part of RCF~~

~~POST Technologies is responsible for providing the cabling in order to have an end-to-end optical connection form ODF to the Operator rack.~~

~~3.5.1.2.2 FO-VZ Operator rack part of RCF~~

~~Break out cables with 24 fibres shall be used for this part of the RCF. The Operator shall only order new RCFs when 75% of previously installed RCF fibres are used. Per order a maximum of 3 x 24 fibres is allowed.~~

~~The marking of the RCF shall be done by the Operator. After ordering a new RCF, the Operator will receive the designations of the different fibres. It is the Operator's responsibility to mark the fibres on the break out cable according to these designations on both ends of the break out cable.~~

~~3.5.1.3. Operator rack connection in case of an Operator's rack installed in a shelter~~

~~POST Technologies will install the RCF, which in this case the RCF consists of a fibre optic cable as specified in paragraph 2.6.1.3, and connect the fibres to the ODF and to the OHDF installed in the Operator's outside shelter. The RCF consisting of a fibre optic cable will be installed in increments of 48 fibres—a new order shall only be placed if 75% of the capacity of all RCFs belonging to a given Operator is used.~~

~~Orders of RCFs will be done in increments of 48 fibres.~~

~~The marking and testing of the RCF shall be done by POST Technologies. To install the termination panels of the OHDF, the Operator shall grant POST Technologies access to its shelter.~~

3.5.2. General principles for ordering RCFs

The Operator can order RCFs through a written firm order, which shall define and detail precisely per used ODF Site the required capacity according to the rules described in 3.5 and specify the Ready for Service Date at which the Operator wants the said RCF to be ready. In any case, the effective Ready for Service Date of RCFs shall not occur before T30 as from the firm order effective date. POST Technologies shall confirm the receipt of every firm order and inform the Operator when the installation of the related RCFs and termination panels is completed.

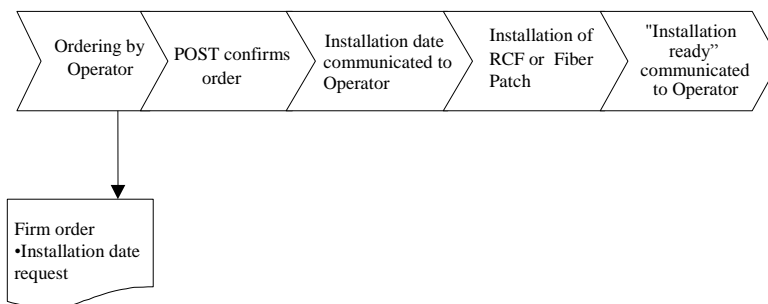

Figure 7 : Overview of the ordering process of tie cables

3.5.3. Term and billing

The minimum period of service for any RCF shall be twelve (12) months as from its Ready for Service Date. If an Operator terminates a RCF service before the end of the said minimum period of service, the Operator shall pay to POST Technologies a sum equal to twenty percent (20%) of the rental charges applicable to

such a RCF, being the rental charges applicable on the Ready for Service Date and calculated for the remaining period of its minimum term of service.

For each RCF and associated products and services ordered by the Operator, the Operator shall pay to POST Technologies monthly in advance the applicable connection and rental charges as specified in Schedule 10.

3.6. Provisioning of tie cable

3.6.1. General

Orders shall relate to Operator's dedicated equipment, which consists in tie cables and associated Operator's termination blocks.

All installations shall be done by POST Technologies directly or by POST Technologies' subcontractors, as appropriate.

Forecasts and ordering shall be done by the Operator per Local Exchange and for each type of tie cable.

In case of missing or incorrect data, the concerned Forecast or order shall be rejected and the reasons for the rejection will be specified in POST Technologies' reply message.

All Forecasts and firm orders shall be submitted by email to ordering.technologies@post.lu.

Irrespective of the terms and conditions stated below, POST Technologies reserves the right to reject any Forecasts for a given Local Exchange in case the volumes requested by the Operator for the concerned Local Exchange in the said Forecasts are not in line with reasonable market demands.

3.6.2. Ordering Procedure

The Operator can order tie cabling through a firm order, which shall define and detail precisely for all concerned Local Exchange(s) all the capacity(ies) requested per type of tie and specify the Ready for Service Date at which the Operator wants the said tie cabling to be ready. In any case, the effective Ready for Service Date of tie cabling shall not occur before T30 as from the firm order effective date. POST Technologies shall confirm the receipt of every firm order and inform the Operator when the installation of the related tie cables and termination blocks is completed.

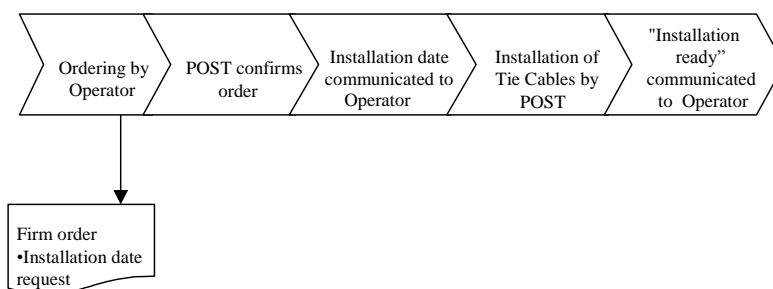

Figure 8 : Overview of the ordering process of tie cables

~~3.6.3. Term and billing~~

~~The minimum period of service for any tie cable shall be twelve (12) months as from its Ready for Service Date. If an Operator terminates the tie cable service before the end of the said minimum period of service, the Operator shall pay to POST Technologies a sum equal to twenty percent (20%) of the rental charges applicable to such tie cable, being the rental charges applicable on the Ready for Service Date and calculated for the remaining period of its minimum term of service.~~

~~For each tie cable and associated products and services ordered by the Operator, the Operator shall pay to POST Technologies monthly in advance the applicable connection and rental charges as specified in Schedule 10.~~

~~3.6.4. Tie cables~~

~~Each order for internal copper tie cables to be passed by the Operator for a given Co-Location Equipment Room shall cover a minimum capacity of (i) one hundred (100) pairs for Unbundling Services while the maximum capacity that may be ordered in one time shall be strictly limited to five hundred (500) pairs.~~

~~The Operator may order additional internal tie cable capacity when the net amount of available connections per internal tie cable type within a given Co-Location Equipment Room is equal or inferior to one hundred (100) pairs.~~

~~Subject to priority agreed Forecasts, POST Technologies shall make reasonable endeavours to provide the ordered internal tie cables within T30 to the Operator. Tie cables can also be provided in relation to a new Co-Location Equipment Room project and shall in such case be part of the related overall planning and timing.~~

3.7.3.5. Provisioning Procedure for Metallic Path Facility

~~3.7.1.3.5.1. Appointment handling~~

The following appointment handling procedure is valid for and applicable to the provision of copper-based LLU Services (including MPF, MPFNP). For the provision of the LLU Services, timely and suitable coordination between POST Technologies, the Operator and the Operator's concerned End User is required in order to fulfil and achieve the installation of the LLU Services.

Each Operator shall take an active part in the POST Technologies booking manager system. This Web based application enables the on-line reservation of available appointment dates for LLU Services. A complete up to date user documentation is available on POST Technologies' Website.

Appointment dates scheduled on the booking manager system are open to all Operators and are available in a non-discriminatory way based on a strict "first come - first served" principle.

The Operator shall arrange an appointment directly with the concerned End User for the provisioning of the LLU Services and shall reserve this appointment on the booking manager system. After receiving a complete and matching order for this appointment from the Operator, POST Technologies will send to the Operator a confirmation message for the reserved appointment via [the Webservice interface SOAP/XML \(Timeschedule\)](#).

Appointments can be reserved on the booking manager system until three (3) Working Days

before the scheduled appointment date. In case the Operator's End User does not respect the fixed appointment more than 3 times for a given installation, the order will be closed. A new order can be placed by the Operator after clarification of the situation with his End User.

In case an appointment validly notified to POST Technologies cannot be respected, the defaulting Party will inform the other Party without undue delay and the Parties shall further agree upon the next step thereof.

The cancellation of an appointment on behalf of the Operator must be notified to POST Technologies at the latest the previous day of the agreed appointment before 16:00. In case POST Technologies receives the cancellation of an appointment later than the above mentioned timeframe, POST Technologies will charge the full connection charge for that type of service as defined in ~~Schedule 9~~Schedule 9~~Schedule 10~~.

In any case, both Parties shall do their best efforts to respect the notified appointments.

3.7.2.3.5.2. Metallic Path Facility without Number Porting (MPF)

3.7.2.1.3.5.2.1. Definition

The ordering procedure for MPF without migration of service covers the following tiered inter-Party activities:

- The Operator has first to ensure via POST Technologies' eligibility tool that MPF service is available at the given address.
- The Operator submits a MPF order (survey request) and POST Technologies replies to that request either in a positive or in a negative way,
- In case of a positive reply (survey success), the Operator can specify an appointment for that specific MPF on the on-line booking manager system, while POST Technologies shall confirm the date on which the MPF line will be activated by sending a time schedule message.
- In case of a negative reply (survey no-success or survey reject), POST Technologies will give to the Operator a valuable reason why this order request was rejected.

3.7.2.2.3.5.2.2. General considerations

POST Technologies shall not accept any order for MPF unless the following prerequisites have been fulfilled:

- An individual Unbundling Agreement has been signed between the Parties,
- A Co-Location Equipment Room on the concerned MDF Site exists and the installation of tie cable has been completed.

The MPF ordering process is Operator-controlled.

This means that:

- End Users shall directly contact the Operator they wish to purchase telecommunications services from,
- Before signature of an order for MPF, the Operator shall fully and precisely inform

the End User about the procedures and responsibilities in case of providing service to the End User through MPF service and about the related impacts on his/her existing telecommunications services,

- POST Technologies shall not accept any orders for MPF issued directly by an End User,
- Only the Operator shall communicate with POST Technologies,
- Submission of MPF survey request shall only be accepted if made by automatic file transfer via Web service in SOAP format.

In case of doubt or of any claim raised by the End User or by an Operator impacted thereby, the new Operator contracting service with the End User shall provide upon first request and within **five (5) working days** due evidence of the End User's valid consent by submitting the original request-form signed by the End User. Such documents shall be kept and archived by the Operator at least for the period specified by applicable Luxembourg law for contractual documents.

An Operator can submit a survey request for provisioning of MPF in those local networks where this Operator has contracted Co-Location **Spaces/Equipment Room(s)**. To determine the relation between the End User address to his/her serving Co-Location Equipment Room or the relevant **Co-Location Shelter/SLCP**, the Operator can refer to POST Technologies' Internet database dedicated to such inquiries.

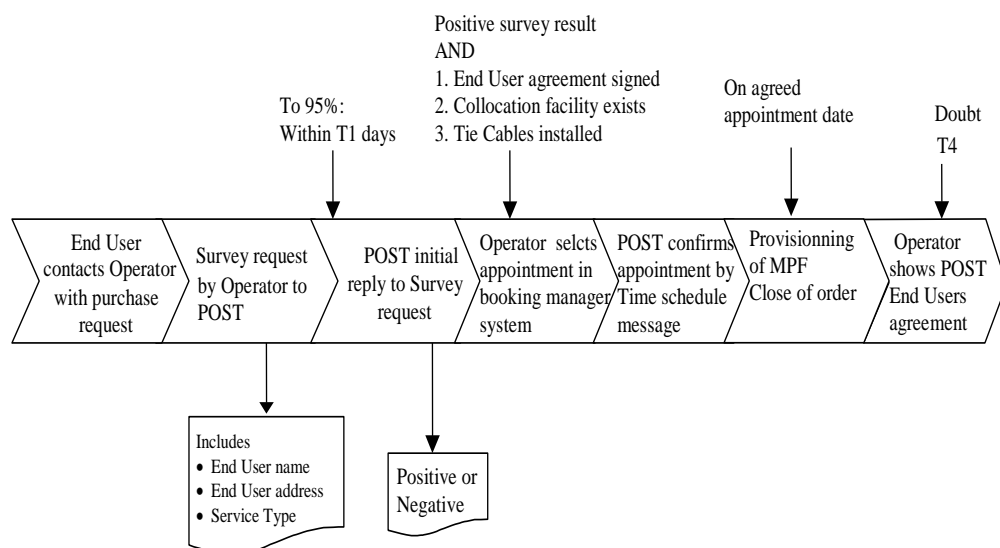

Figure 669 : Ordering process for MPF

3.7.2.3.3.5.2.3. Submission of an MPF survey request

The Operator shall submit an MPF_Survey Request of the provision type "New Line" to POST Technologies

A submitted MPF survey request shall contain at least the following information:

- Operator's Reference Number,
- Full End User's name,

- End User's exact installation address, including relevant floor and flat number indications
- MDF number,
- Provision Type: "New Line",
- Service Type requested (narrow band or broadband).

POST Technologies will respond to such survey request within the timescale defined in ~~this RUO Schedule 11~~ by sending back either (i) a negative survey answer indicating the relevant reasons thereof, or (ii) a positive answer with the relevant technical information on the MPF.

The following reasons will nevertheless lead to a negative survey answer:

- End User's address is not connected to POST Technologies' local network,
- Address is not served by the indicated MDF or SLCP,
- MPF is not available for the requested service quality,
- Unallocated MPF is not available to the End User's address,
- Unallocated MPF is not available in intermediate sections in the local network,
- Unallocated tie cable capacity is not available,
- Allocation of MPF for broadband is inhibited due to interference problems on that section of the network,
- Allocation of MPF for broadband is inhibited due to cable lengths greater than 6000 m on that section of the network.

A complete up to date list of the reasons leading to a negative survey is published on POST Technologies' Website, including the order of the analysis of the parameters of the survey.

POST Technologies will endeavour to reply to ninety-five percent (95%) of the received survey requests within ~~five (5) working days~~^{T1}.

In case the key conditions of MPF submission are met and essential information has been provided, POST Technologies will handle all received valid survey requests in a non-discriminatory way based on the "first come/first served" principle and in the same manner it handles its own internal requests for MPF.

While performing a survey for MPF, POST Technologies will reserve the involved elements of POST Technologies Infrastructure for a period of ~~five (5) working days~~^{T2}, as defined in ~~Schedule 10~~^{Schedule 11}. If in the meantime no appointment date for the line activation has been received from the Operator for provisioning the allocated MPF, the MPF survey shall be cancelled and the reservation of the allocated POST Technologies Infrastructure elements, as set forth here above, be automatically levied.

In case the survey performed by POST Technologies results in:

- a positive answer to a survey for MPF services, POST Technologies will provide to the Operator the cable length information of the reserved MPF as well as POST Technologies' reference number in case of survey success; or

- a negative answer, no other action is taken by POST Technologies as far as the POST Technologies' search engine showed a spare copper route for a specific address. Howsoever, in case the search engine indicated that no copper route is available, POST Technologies shall charge the amount applicable to the negative survey as specified in ~~Schedule 9~~Schedule 10.
- a positive answer and if the Operator does not place a MPF provisioning order in due time, POST Technologies shall charge the amount applicable to the survey as specified in ~~Schedule 9~~Schedule 10.

The Operator shall pay a survey charge in case of a positive answer by POST Technologies followed by a cancellation request of the Operator before the activation date or if no appointment date is taken on booking manager system within due time.

~~3.7.2.4.3.5.2.4.~~ Order for Provisioning of MPF

After notification of a positive survey, the Operator shall coordinate forthwith an appointment date with the concerned End User and formally reserves one of the free time slots in POST Technologies' on-line booking manager system. After proper reservation of the appointment date, the concerned time slot shall no longer be available for other Operators. POST Technologies shall validate the appointment and confirm the activation date by sending ~~an electronic XML~~ message "MPF Time Schedule" to the Operator.

A maximum delay of three (3) months between the current date and the appointment date is allowed.

At the confirmed activation date, POST Technologies will connect the MPF in the network and test the line from the MDF to the NTP at the End User's premises.

In case of positive testing, the end point of the MPF on the MDF will be the jumper to the indicated connection point of the Operator's tie cable.

The Operator shall be responsible for all the services deployed on this line as from the activation date onwards.

Should the requested MPF installation fail for any of the below reasons, POST Technologies shall inform the Operator by the electronic messaging system:

- Failure to meet the relevant test,
- Defect copper pair in a section,
- Discrepancy between data for reserved MPF and physical availability of pairs in the network,
- Damaged cable within a section of the path for that MPF.

POST Technologies will endeavour to find an alternative solution to provide the MPF as ordered by the Operator in ~~a T6~~ five (5) working days time period. If reasonable means do not allow the MPF provisioning to the Operator, POST Technologies shall send a final failure message to the Operator.

A final failure message shall also be sent in case of any of the following reasons:

- No availability of alternative solution to initially reserved MPF routing,
- Incoherence in the allocation of tie cable connection points,
- Mismatch between MPF type and indicated connected equipment type,
- Mismatch between MPF survey request and MPF provisioning order.

3.7.2.5.3.5.2.5. Connection of the in-house cabling at the End User premises

POST Technologies' MPF responsibility terminates at the NTP as described in [Schedule 2](#) ~~Schedule 2~~.

In case the Operator wants to connect additional in-house cabling to POST Technologies' NTP, it is entitled to connect the cables to distribution boxes of single-unit houses or to the cross-connection distribution frame of corporate customers.

In case additional in-house cabling is to be connected to an NTP in a multi-tenant premise, the Operator shall specify it in its order for MPF provisioning. At the moment of MPF installation, POST Technologies will introduce the cable in the NTP box.

If the Operator or the End User wants to deviate from the above-mentioned standard, this shall also be expressly indicated in the order for MPF provisioning. A non-standard connection will normally need a modification at the NTP level and a specific survey will be required. In this case, normal timing as defined for the MPF provisioning shall not apply.

~~3.7.3.~~3.5.3. MPF combined with Number Porting (MPFNP)

~~3.7.3.1.~~3.5.3.1. Definition

This process allows the Operator to migrate ~~take over~~ an active telephony service ~~provided by POST Technologies to an MPF together with the main number and multiple subscriber numbers (MSN) allocated to this line~~ Service. Number porting in itself is considered optional and the process only covers the migration of the copper infrastructure used for the existing telephony service referred to by its phone number. Considering the complexity of combined provisioning, this procedure is limited to the above-mentioned types of service.

A combined MPFNP service can be ordered in two different manners, either as "swap express" or as "swap classic". The search engine "phone search" published on POST Technologies' Website for Operator services allows to check for each phone number if a MPFNP service can be provided as "swap express" or as "swap classic":

3.7.3.2.3.5.3.2. MPFNP can be handled as provision type "swap express", if the existing active line is routed entirely on copper from the network termination point (NTP) on the customer site to the main distribution frame (MDF) on the office site. In this case the swap of the line only requires modifications on the MDF, while no works in the field have to be carried out.

- After the Operators submission of a survey request for the provision type "swap

express", POST Technologies will reply to that request in a positive or negative way

- In case of a positive survey, the swap of the line will be executed by POST Technologies in a time frame between Working Day D+3 and D+7 after the positive survey response "survey success" to the Operator without any further action to be done by the Operator. No appointment has to be reserved through the online booking manager for this provision type.
- POST Technologies will confirm the activation of the MPFNP service by sending an electronicXML message "MPFNP Activated" to the Operator

3.7.3.3.3.5.3.3. MPFNP will be handled as provision type "swap classic", if the existing active line is not an end to end copper circuit. In this case the routing of the line has to be modified requiring works to be done by the POST Technologies in the field.

- After the Operator's submission of a survey request for the provision type "swap classic", POST Technologies will reply to that request in a positive or negative way
- In case of a positive survey, the Operator shall coordinate an appointment date with the concerned End User, and specify this appointment on the on-line booking manager system
- POST Technologies will confirm the activation date by sending an electronicXML message "MPFNP Time Schedule" to the Operator. At the confirmed activation date the swap of the line will be executed by POST Technologies.
- POST Technologies will confirm the activation of the MPFNP service by sending an electronicXML message "MPFNP Activated" to the Operator

3.7.3.4.3.5.3.4. General considerations

POST Technologies shall not accept any order for MPFNP unless the following prerequisites have been fulfilled:

- An Unbundling Agreement has been signed by the Parties.
- ~~An individual agreement for telephony service interconnection and number portability has been signed by the concerned Operator.~~
- A Co-Location Equipment Room or Co-Location Shelter on the concerned MDF or SLCP Site exists and the installation of an tie cable has been completed.

The MPFNP ordering process is Operator-controlled.

This means that:

- End Users shall directly contact the Operator they wish to purchase telecommunications services from,
- POST Technologies will not accept any orders for MPFNP issued directly from an End User,
- Only the Operator shall communicate with POST Technologies,
- The contract(s) relating to currently provided End User services by an Operator shall be terminated in compliance with the terms and conditions applicable to the

said telecommunication services.

- ~~The Operator has to assure that all prerequisites and required formalities in relation to the "Procedure for number portability" as defined by the "Number Portability" working group in May 2000 are respected.~~

In case of doubt or of any claim raised by the End User or by an Operator impacted thereby, the new Operator contracting service with the End User shall provide upon first request and within five (5) working days^{T4} due evidence of the End User's valid consent by submitting the original request-form signed by the End User. Such documents shall be kept and archived by the Operator at least for the period specified by applicable Luxembourg law for contractual documents.

An Operator can submit a survey request for provisioning of MPF in those local area networks where this Operator has contracted Co-Location Equipment Room(s). To determine the relation between the End User address and its serving Co-Location Equipment Room or the relevant SLCP, the Operator can refer to the POST Technologies' Internet database dedicated to such inquiries.

Orders for MPFNP survey request can only be submitted by exchanging electronic XML messages via a Web service ~~in SOAP format~~.

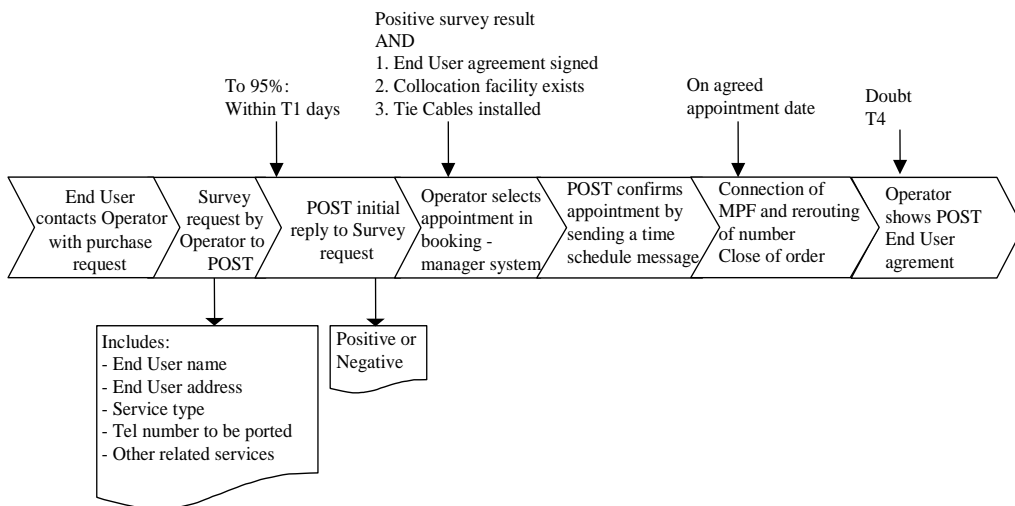

Figure ~~7710~~ : Ordering process for MPFNP

3.7.3.5.3.5.3.5. Submission of an MPFNP survey request

A submitted MPFNP survey request shall contain at least the following information:

- Operator's Reference Number,
- End User's name,
- End User's exact installation address, including precise information about the relevant floor and flat number,
- End User's POST Technologies account number (required for automated process), (this number has to be given by the End User to the Operator, and the End User has the easy possibility to obtain this number by following the procedure

mentioned in ~~Schedule 10~~[Schedule 9](#) of this RUO)

- MDF number,
- Provision Type, "swap express" or "swap classic"
- Service Type Requested (Narrowband, Broadband),
- Service to be migrated and if related services are active on that number or line,
- End User's telephone number(s) to be ported,
- Line Detail (Multi-line without secondary number).

POST Technologies will respond to this survey request within T1 as defined in ~~Schedule 10~~[Schedule 11](#) by sending back either a negative or a positive survey answer, the latter including relevant technical information on the concerned MPF. If the key conditions of MPFNP delivery are met and essential information has been provided, POST Technologies shall not reject a request.

A complete up-to-date list of the reasons leading to a negative survey is published on POST Technologies' Website, including the order of the analysis of the parameters of the survey.

In case of a negative survey answer, POST Technologies shall indicate the relevant reasons thereof, it being specified that the following reasons shall lead to a negative survey answer:

- Presently used MPF is provided through a pair gains system,
- Address is not served by the indicated MDF,
- Unallocated tie cable capacity is not available,
- Allocation of MPFNP for broadband is inhibited due to cable length greater than 6000m on that section of the network,
- Any of the reject reasons as specified in the number portability document from May 2000 as defined by the working group.

In case the survey performed by POST Technologies results in a negative answer, no other action is taken by POST Technologies as far as the POST Technologies' search engine showed a spare copper route for a specific address. Howsoever, in case the search engine indicated that no copper route is available, POST Technologies shall charge the amount applicable to the negative survey as specified in ~~Schedule 9~~[Schedule 9](#)~~Schedule 10~~.

In case the survey performed by POST Technologies results in a positive answer and the Operator does not place a combined provisioning order, POST Technologies will charge the amount for the survey as indicated in the price ~~Schedule 9~~[Schedule 9](#)~~Schedule 10~~.

The Operator shall not pay the survey charge in case of a positive answer followed by a firm provisioning order issued by the Operator.

~~3.7.3.6~~[3.5.3.6](#). Order for provisioning of MPFNP

After notification of a positive survey, the Operator shall, in case of an MPFNP service

ordered with the provision type "swap classic", coordinate an appointment date with the concerned End User and formally reserve one of the free availabilities on the POST Technologies' on-line booking manager system. After proper reservation of the appointment date, the concerned time slot shall no longer be available for other Operators. POST Technologies shall validate the appointment and confirm the activation date by sending a XML message "MPF Time Schedule" to the Operator.

In case of a MPFNP service ordered with the provision type "swap express" the Operator does not need to fix an appointment with the concerned End User. The activation of the MPFNP service will automatically be executed in a time frame of Working Day D+3 and D+7 after the confirmation of the positive survey by POST Technologies. The actual activation of the MPFNP service will be confirmed to the Operator by sending an XML message "MPFNP activated"

The migration shall be achieved in the following way:

- Connection by POST Technologies of the MPF to the indicated connection point of the Operator's tie cable,
- Activation by POST Technologies of the number re-routing in POST Technologies' network to transfer calls to the Operator's network,
- Testing by the Operator of the successful service migration and confirmation of the successful migration by the Operator to POST Technologies,
- As from the activation of the successful migration onwards, the Operator shall be responsible for all services deployed on the concerned line,
- In case migration of service has not been performed successfully, POST Technologies will re-establish the initial situation and both Parties shall then liaise to identify the underlying problem,
- In case of successful migration, the Operator will inform the other Operators that the number porting has taken place in compliance with the procedure for number portability.

Should the migration of the related service not be achievable within the fixed time frame(s) as the End User's line is damaged or not active at the time the said migration should have taken place, POST Technologies shall inform the Operator thereof also by email and endeavour to propose a new migration date, as soon as the re-establishment of the MPF will allow it.

POST Technologies shall nevertheless send a final failure message in case of any of the following situations:

- Incoherence in the allocation information of tie cable connection points provided by the Operator,
- Planned physical change in POST Technologies' local network,

Once rejected, a request shall be closed in the database with the indication of the appropriate reject reason code(s). The combined order for provisioning of MPF and number porting shall be abandoned at this time and appropriate information shall be sent back to the Operator.

3.7.4.3.5.4. Transfer of MPF

3.7.4.1.3.5.4.1. Generalities

An active telephony or broadband service provided through LLU Services, can be subject to a subsequent transfer ~~together with the main number and Multiple Subscriber Numbers (MSN) allocated to this line~~ from a Donor Operator to a Recipient Operator.

The Recipient Operator can cancel the service of a Donor Operator, provided the End User has prior requested such cancellation by formally signing the necessary authorisation form and confirming expressly that it has complied with all its contractual obligations vis-à-vis the Donor Operator.

3.7.4.2.3.5.4.2. Transfer of MPFNP from a Donor Operator to a Recipient Operator

For transfer of an active MPF ~~combined with number porting, the standard procedure for number porting as defined by the working group in the document of May 2000, shall be complied with between the Donor and the Recipient Operators.~~

~~In this respect,~~ the Recipient Operator shall submit a survey request to POST Technologies, which shall handle such request in line with this Schedule 3~~Schedule 3~~.

The subsequent combined order for MPF transfer ~~and number porting~~ shall be handled in the following way:

- Migration shall be done by POST Technologies at the date and time validated on the POST Technologies' on-line booking manager system,
- Disconnection by POST Technologies of the concerned MPF from the previous tie cable of the Donor Operator and its connection to the indicated connection point of the Recipient Operator's tie cable, all this by POST Technologies,
- Information by POST Technologies to the Recipient Operator (via phone or email) of the migration achievement and of the number rerouting activation,
- Testing by the Recipient Operator of the successful service migration and confirmation thereof to POST Technologies,
- Information via an electronic XML message to the Recipient Operator that the line has been activated and to the Donor Operator that the line has been migrated.
- As from the moment of successful migration activation onwards, the Recipient Operator shall be responsible for all services deployed on this line.

In case service migration has not been performed successfully, POST Technologies shall proceed to validate the MPF transfer between tie cables. In case no abnormal situation can be stated at this level, POST Technologies will re-establish the initial situation while the Donor and Recipient Operators shall liaise without undue delay to identify the underlying problem,

~~In case of successful migration, the Recipient Operator shall inform the other Operators that~~

~~the number porting has taken place in compliance with the above mentioned procedure for number portability.~~

~~In case of unsuccessful transfer, POST Technologies shall update its database accordingly and send a closing message back to the Recipient Operator per e-mail.~~

~~In case of a transfer of an active MPF together with number porting, POST Technologies may handle the number porting for practical reasons and if technically feasible.~~

~~3.7.5.3.5.5.~~ **3.5.5. Hand-back Procedure**

In case an End User terminates its services provided by the Operator through MPF, this Operator shall inform POST Technologies within two (2) working days~~T8~~ that the MPF has become available for reallocation.

The Operator shall send this hand-back information by electronic messaging.

To avoid any undue disconnections, the hand-back message shall contain at least the following mandatory information:

- Operator's Cancellation Reference,
- Old Operator's Reference,
- Old POST Technologies' Reference,
- ~~Type of hand-back (MPF or MPFNP),~~
- Tie-cable connection point number,
- Full End User's name,
- End User's address,
- Disconnection Due Date.

POST Technologies shall confirm the hand-back message by an electronic XML message "MPFNP CANCELLATION" sent to the Operator within two (2) working days~~T9~~.

This allows the Operator to re-use the "Tie-Cable Connection point number" from that time onwards (without any further delay managed by POST Technologies).

At the date POST Technologies receives all relevant and correct hand-back information, the rental billed to the Operator for this line shall be terminated. The applicable termination fee shall be charged on the last rental bill.

In case of incoherence of the submitted mandatory hand-back information after validation in POST Technologies' database, this stated incoherence will be indicated in a reply message to the Operator.

The MPF shall not be disconnected until the incoherence has been duly clarified with both Parties' best endeavours. The rental of the MPF billed to the Operator shall continue until the MPF can finally be effectively disconnected.

~~3.7.6.~~3.5.6. Cancellation of an order before activation

If an Operator wants to abandon its request for MPF after submission of a formal order by the electronic messaging system, it shall send a cessation order by e-mail to POST Technologies, which shall specify at least the following information:

- MPF number,
- Tie cable connection point number,
- Full End User's name,
- End User's address.

If the date of receipt of the order cancellation by POST Technologies is more than two (2) working days~~T5~~ ahead to the agreed appointment date with the End User, POST Technologies will cancel the order and the Operator shall pay the MPF charge for order cancellation before activation as well as the related survey charge, as defined in Schedule 9~~Schedule 9~~Schedule 10.

In case POST Technologies receives the cessation order less than two (2) working days~~T5~~ before the agreed appointment date with the End User or in case of a MPFNP order, POST Technologies will cancel the order and charge the full connection charge for that type of service as defined in Schedule 9~~Schedule 9~~Schedule 10, while the survey charge shall not be due.

POST Technologies will send a confirmation message back to the Operator within two (2) working days~~T9~~.

~~3.8. Provisioning Procedure of DSS~~

~~3.8.1. Quoting Process~~

~~A first request needs to be sent by email to quote.technologies@post.lu~~

~~Upon request by the Operator on a specific project, network plans and maps indicating the duct routes and the location of the chambers will be provided to the Operator so it can plan a site survey and organize its work deployment.~~

~~Please note that the plan transmitted to the Operator reflects the infrastructure at the time of the request based on available information and according to the best of knowledge of the POST Technologies staff. However, the availability and the circumstances of the ducts can change over time and may vary between the first request and the final order.~~

~~In order to become familiar with the routes, an onsite inspection of the facilities can be scheduled between a POST Technologies technician and the Operator. The time spent by the POST Technologies technician on the site survey and/or to supply the Operator with the required information will be charged to the Operator on a per hour basis depending on the complexity of the project. The applicable tariffs are specified in Schedule 10.~~

~~The Operator can plan the architecture of their duct routes on their own (based on the plans transmitted by POST Technologies) or leave the design of the routes to POST Technologies. POST Technologies will then proceed to a study period that consists of reviewing all sections and of determining the architecture of the duct routes that are the most suitable, taken into account the technical constraints. If the circuit the Operator requests is not available according to the rules and principles of POST Technologies, an alternative route may be given to the Operator.~~

Once the specifications and the details of request have been fixed, POST Technologies will respond with a formal offer after T1 with the feasibility of the project, the tariffs and an indication of the estimated time of completion. The time of completion however depends on some external factors e.g. construction permit, weather conditions, etc. which cannot be controlled by POST Technologies and may cause an extension to the estimated time of completion. The offer will be valid for 6 weeks upon receipt.

3.8.2. Ordering Process

After the quoting phase the Operator needs to submit a final order by email to ordering.technologies@post.lu

When placing an order for DSS, the Operator shall specify the required access points to POST Technologies infrastructure and the duct routes.

For every prior work done by the Operator, the Operator must inform POST Technologies of which chambers will be interconnected (ingress and egress) and which works will be carried out. Notifications have to be submitted ten (10) days in advance of the planned works to POST Technologies' competent department ("Service de projection et Extension Réseau Fixe") to the following email address: projection_extension@post.lu with the following information:

- Operator
- Contact person
- No phone contact
- No contact email
- Order number
- Plot place / street
- Expected date of the intervention
- Description of intervention
- Name of the sub-contractor

3.8.3. Implementation Process

The Operator or its subcontractor carrying out civil works must be in full possession of all the authorizations required for the execution of the installation work. Whenever the supervision of POST Technologies is required, then the installation works will have to be carried out on Working days within Business Hours.

The installation date of a cable or a micro tube must be communicated to POST Technologies at least ten (10) Working Days in advance.

The Operator is not allowed to install any of their equipment into a chamber belonging to POST Technologies. Joint closures, excess of cables or micro tubes must be accommodated in one of the Operator's separate chambers and, depending on the type of works, on site supervision of POST Technologies might be required.

Opening and accessing the chambers or manholes is strictly prohibited without the presence of a POST Technologies technician, respectively without the prior agreement of POST Technologies. Furthermore, before delivering a duct, POST Technologies will proceed to some tests in order to check if it is interconnected.

The Operator or its subcontractor must ensure that the telecommunications facilities will not be damaged.

All the needed material, tools and safety equipment required for the installation are to be provided by the Operator. The handling of cables, micro-tubes and existing joints and the pulling or blowing of the cables and micro-tubes must be carried out by a company specialized in this field and accredited by the Operator. A formal accreditation of the sub-contractor by POST Technologies is not mandatory however, POST Technologies reserved the right to remove access to a sub-contractor whose competencies POST Technologies judges as insufficient.

For 30-50mm ducts, fiber optic cables or micro-tubes are to be pulled or blown. However, micro-cables must be blown through micro-tubes. Adequate pulling or blowing gears are to be used.

Micro-tubes must be connected in the chambers in a continuous way.

When working with the micro-tubes, the workers need to make sure that the bending radius is not less than 25 cm.

The chambers are to be opened with the appropriate tools or appliances. In no case a pickaxe, hammer, scissors etc. may be used.

Before accessing the chamber, the subcontractor must proceed to gas detection (carbon monoxide, methane, natural gas, etc.) and must install a device that will indicate whether gas has infiltrated during the execution of installation works. In case of gas detection in a chamber, the person in charge at POST Technologies should be contacted immediately and installation works must be interrupted until further notice. The possible depletion of water in the chambers in preparation of the installation work is to be carried out by the sub-contractor.

Putting up signs on the construction site by the Operator or sub-contractor is to be carried out in accordance with the traffic laws ("Code de la Route").

The Operator and its subcontractors remain the sole parties responsible in case of any accidents or damage that may be caused, in particular to third parties. The works of an external subcontractor remains the sole responsibility of the Operator. If necessary, joints, closures, cables or micro-tubes must be moved under the supervision and following the guidelines of a POST Technologies technician in order to give access to the workplace. In the chambers, the cables and the sub-ducts must be placed and fixed according to the guidelines of the POST Technologies technician. In every POST Technologies chamber, cables, micro-tubes/sub-ducts must be labeled indicating the name of the Operator or subcontractor and the contract number.

After the installation work, cables, micro-tubes and POST Technologies joint closures must be put back into the chambers and fixed according to the guidelines and under the supervision of a POST Technologies technician.

After the installation work, the premises must be cleaned and if necessary secured.

The end of the installation work needs to be notified to POST Technologies' 'Service Projection et Extension Réseau Fixe' by email. POST Technologies may request a final inspection of the chambers in order to audit and validate the conformity of the installations through the issuance of an acceptance protocol.

3.9.3.6. Provisioning procedure of FTTH Fibre Access Services

3.9.3.6.1. Definition

The ordering procedure for FTTH Fibre Access Services covers the following tiered inter-Party activities:

- The Operator's submission of an FA activation request and POST Technologies' reply to that request either in a positive or in a negative way,

- In case of a positive answer, POST Technologies will
 - (i) In case of an Fibre Area-POPs type A in a point-to-point FTTH network : install a direct fibre patch between POST Technologies' ODF and Operator's rack within a target time frame of five (5) working days-T2 following the confirmation of the activation request. For 95% of all requests for FTTH Fibre Access Services, this patching will be carried out within said target time frame of 5 working days.
 - (ii) In case of a Fibre non-Area-POP type B and C in a point-to-point FTTH network : install a fibre patch between POST Technologies' ODF and anthrough- existingthe pre-ordered RCF to Operator's rack of the Operator within a target time frame of five (5) working days following the confirmation of the activation requesttime-frame-T2. For 95% of all requests for FTTH Fibre Access Services, this patching will be carried out within said target time frame of 5 working days.
 - (iii) In case of a point-to-multipoint FTTH fibre : carry out the splicing works in order to connect the fibre to an existing splitter dedicated to the Operator within the SLCP within a target time frame of twenty (20) working days following the confirmation of the activation request. For 95% of all requests for FTTH Fibre Access Services, this splicing will be carried out within said target time frame of 20 working days. If no splitter exists or if an additional splitter has to be installed to increase capacity, the said target time frame is not applicable
- In case of a negative answer, POST Technologies will give to the Operator a valuable reason why this activation request was rejected.
- After installation POST Technologies will send a message "FAO_Activated" to the Operator. Billing period will begin at the first Working Day after the sending of the "FAO_Activated" message to the Operator.

3.9.2.3.6.2. General considerations

POST Technologies shall not accept any order for FTTH Fibre Access Services unless the following prerequisites have been fulfilled:

- An individual RUO Agreement has been signed between the Parties.
- A Co-Location Floor Space or Rack Space on the concerned ODF Site exists.
- The installation of a RCF has been completed in case the ODF is located in a Fibre POP type B or C.
- The FTTH Fibre Access ServiceA ordering process is Operator-controlled.

This means that:

- End Users shall contact directly the Operator they wish to purchase telecommunications services from,
- Before signature of an order for an FTTH Fibre Access Service FA-Service the Operator shall fully and precisely inform the End User about the procedures and responsibilities in case of providing service to the End User through FTTH Fibre Access Service FA-Service and about the related impacts on his/her existing telecommunications services. Any End User's existing

service from POST Technologies will continue to be provided and billed unless the End User cancels this Service himself,

- POST Technologies shall not accept any orders for FTTH Fibre Access FA-Services issued directly by an End User,
- Only the Operator shall communicate with POST Technologies.
- Submission of FTTH Fibre Access ServiceFA activation request shall only be accepted if made by automatic file transfer via Web service interface. SOAP format.

In case of doubt or of any claim raised by the End User or by an Operator impacted thereby, the new Operator contracting the service with the End User shall provide upon first request and within five (5) working daysT4 due evidence of the End User’s valid consent by submitting the original request-form signed by the End User. Such documents shall be kept and archived by the Operator at least for the period specified by applicable Luxembourg law for contractual documents.

An Operator can submit a survey request for provisioning FTTH Fibre Access Service of FA Service in those local area networks where this Operator has contracted Co-Location Floor Space or Rack Space. To determine the relation between the End User address to his/her serving ODF site, the Operator can refer to the POST Technologies’ Internet database dedicated to such inquiries.

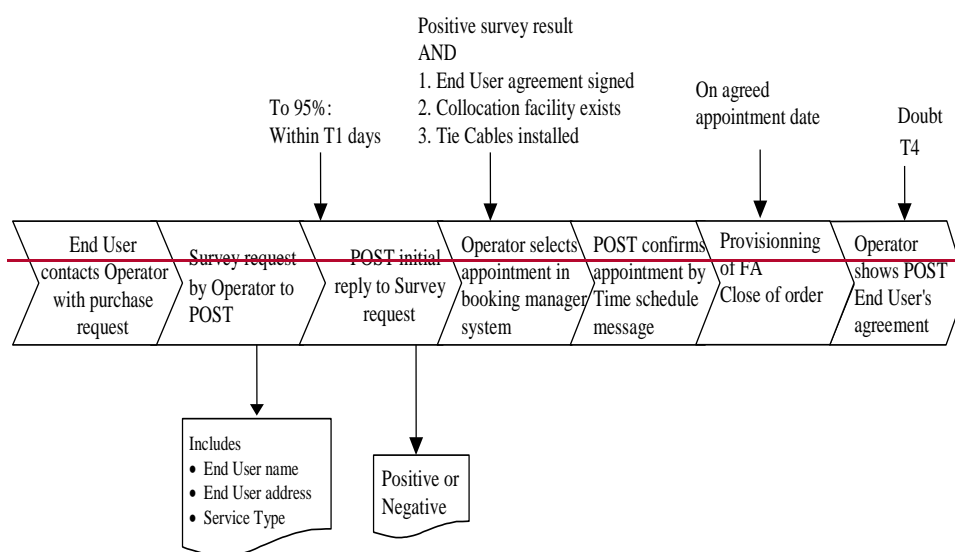

Figure 11 : Ordering process for FA Services

3.9.3.3.6.3. Appointment handling and Provisioning Process of the patch cord in the Fibre POP

The following appointment handling procedure is valid for and applicable to the provision of FA Services. For the provision of the FTTH Fibre Access ServicesFA Services, timely and suitable coordination between POST Technologies, the Operator and the Operator's concerned End User is required in order to fulfil and achieve the installation of the FTTH Fibre Access ServicesFA Services.

After the Operator's transmission of an FTTH Fibre Access Service FA-activation request, POST Technologies will answer in a successful case to the Operator with an ~~XML~~ message of the type "FAO_Activation success" containing all necessary information e.g. order number, circuit number, ODF connection point, etc. Upon this, POST Technologies will install within ~~thea target~~ time frame ~~T2~~ the corresponding fibre patches between POST Technologies' ODF and the Operator's rack or between POST Technologies' ODF through the pre-ordered and installed RCF to the Operator's rack as described in ~~Schedule 2~~Schedule-2 and ~~Schedule 3~~Schedule-3. After installation of the fibre patches, POST Technologies will send to the Operator an ~~XML~~ message of the type "FAO_Activated" and close the FTTH Fibre Access Service FA-order process.

The Operator shall arrange an appointment directly with the concerned End User for the fulfilment of the provisioning of the FTTH Fibre Access Services after receiving the "FAO Activated" message from POST Technologies. POST Technologies will not intervene at the End User premises.

The Operator shall be responsible for all the services deployed on this line as from the installation date onwards.

POST Technologies shall inform the Operator by the electronic messaging system, should the requested FTTH Fibre Access Service installation fail for any of the reasons below :

- Defect optical fibre in a section,
- Damaged cable within a section of the path for that FTTH Fibre Access ServiceA,
- Incoherence in the allocation of tie cable connection points.

3.9.4.3.6.4. Submission of an FTTH Fibre Access ServiceA Activation Request

The Operator shall submit a FTTH Fibre Access Service Activation Request of the provision type "FAO New" to POST Technologies ~~in the form of a XML message using the Web service interface~~ as described in the documentation published on POST Technologies' Website.

A submitted FTTH Fibre Access Service FA-Activation Request shall contain all mandatory data as described in the above-mentioned documentation.

POST Technologies will endeavour to reply to ninety-five percent (95%) of the received Activation Requests within the timescale ~~of one (1) working day T1 defined in Schedule 11~~ by sending back either (i) a negative answer (FAO ActivationNoSuccess) indicating the relevant reasons thereof, or (ii) a positive answer (FAO ActivationSuccess) with the relevant technical information on the FTTH Fibre Access ServiceFA.

The following reasons will nevertheless lead to a negative survey answer:

- Mandatory ~~electronicXML~~ file information is missing or incorrect,
- End User's installation address is not complete or cannot be determined,
- End User's address is not connected to POST Technologies' ~~point-to-point~~-FTTH local

network,

- Address is not served by the indicated ODF,
- Unallocated RCF capacity is not available.

A complete up-to-date list of the reasons leading to a negative answer is published on POST Technologies' website, including the order of the analysis of the parameters of the survey.

In case the key conditions of [FTTH Fibre Access Service FA](#)-submission are met and essential information has been provided, POST Technologies will handle all received valid Activation Requests in a non-discriminatory way based on the "first come/first served" principle and in the same manner it handles its own internal requests for [FTTH Fibre Access Service FA](#).

In case the Activation Request results in:

- a) a positive answer to an Activation Request for [FTTH Fibre Access FA](#)-Services, POST Technologies will provide to the Operator a POST Technologies service order number reference number of the circuit as well as the connection point in the ODF. POST Technologies will install the fibre patches in the Fibre POP between POST Technologies' ODF and the Operator's rack within ~~the specified target time frame~~[a time frame of T2](#) and send afterwards a ~~XML~~-message "FAO_Activated" back to the Operator. The billing period for the [FTTH Fibre Access Service FA Service](#) will start on the first Working Day following the sending of the activated message.
- b) a negative answer, no other action is taken by POST Technologies as far as the POST Technologies' search engine showed a spare [FTTH Fibre Access Service FA](#)-route for a specific address. However, in case the search engine indicated that no fibre route is available, POST Technologies shall charge the amount applicable to the negative answer as specified in ~~Schedule 9~~[Schedule 9](#)~~Schedule 10~~.

~~3.9.5.~~[3.6.5.](#) Connection of the in-house cabling at the End User premises

The Operator will proceed to the installation at the End User's premises and is responsible for any related connection and installation.

To get familiar with the different types of FO-NTPs and avoid service interruptions at the End User's premises, the Operator has to follow a mandatory training course on fibre management and installation at POST Technologies' offices ~~at 2 rue Emile Bian, L-1235 Luxembourg~~. This course handles the theory and practice of the fibre management and installation of pigtails and patch cords on all of ~~POST~~ Technologies' FO-NTP types. ~~The related phone number for an appointment is 4991-5779 and t~~[The applicable fee is specified in ~~Schedule 9~~\[Schedule 9\]\(#\)~~Schedule 10~~](#).

The instructions given during this introduction must be applied in the field when handling a POST Technologies FO-NTP.

In case the Operator has problems to successfully finish the connections on the FO-NTP or has damaged one or more fibres, the procedure described in [4.1.24-1-2](#) applies. POST Technologies' [FTTH Fibre Access Service FA-service](#) responsibility terminates at the FO-NTP described in [Schedule 2](#)~~Schedule 2~~. All eventually necessary in-house cabling as well in single-unit houses as in multi-dwelling buildings have to be realised under the responsibility of the Operator. It is not allowed to disconnect any equipment on the End User's premises until the End User has cancelled the services delivered by this equipment.

Before the Operator submits an [FTTH Fibre Access Service FA](#)-survey request for a multi-dwelling building, it has to check if an optical fibre in-house cabling exists and is terminated inside the concerned End User's premises. The Operator transmits this information during [FTTH Fibre Access Service FA](#) activation request to POST Technologies.

In multi-dwelling buildings where the Operator detected a fully installed optical fibre in-house cabling connected to the FO-NTP and connected inside the End User's premises, POST Technologies will realise inside the FO-NTP the connection between incoming optical fibre and the fibre optical in-house riser cable.

In multi-dwelling buildings without a fully installed optical fibre in-house cabling, POST Technologies will install an SC-APC 9° hand-over connector outside the FO-NTP that allows the Operator to interconnect the requested fibre to an in-house cabling or equipment he intends to install or has already installed.

If the Operator decides to install itself the optical fibre in-house cabling of the multi dwelling building, it should connect all the apartments of the building, thus avoiding the blocking of the mounting in-house infrastructure only for the cabling of a single End User.

The Operator is responsible for any connection and installation inside the End User's premises.

3.9.6.3.6.6. Hand-back Procedure

In case an End User terminates its services provided by the Operator through [FTTH Fibre Access Services FA Services](#), this Operator shall inform POST Technologies that the [FA Service FTTH Fibre Access Service](#) has become available for reallocation.

The Operator shall send a FAO_deletion request to POST Technologies in the form of an [electronic XML](#) message as described in the documentation published on POST Technologies' Website.

A submitted FA _deletion request shall contain all mandatory data as described in the above-mentioned documentation.

POST Technologies shall confirm a valid FAO deletion request by sending a XML message "FA Deleted" to the Operator within [five \(5\) working days](#)~~T1~~.

This allows the Operator to re-use an eventual "[RCF Tie-Cable](#) Connection point number" from that time onwards.

The rental billed to the Operator for this line shall be terminated at the due date indicated by the Operator in its FAO_deletion message. The indicated due date cannot be prior to the receiving date of the deletion message. If the indicated due date is not a Working Day, the first Working Day following the indicated due date will be taken into account.

In case of incoherence of the submitted mandatory hand-back information after validation in POST Technologies' database, this stated incoherence will be indicated in a reply message to the Operator.

The FTTH Fibre Access Service FA shall not be disconnected until the incoherence has been duly clarified with both Parties' best endeavours. The rental of the FTTH Fibre Access Service FA billed to the Operator shall continue until the FA-FTTH Fibre Access Service can finally be effectively disconnected.

3.9.7.3.6.7. Cancellation of an order before activation

If an Operator wants to abandon its request for FA-FTTH Fibre Access Service after submission of a formal order by the electronic messaging system, it shall send a FAO_cancellation request to POST Technologies in the form of an electronic-XML message as described in the document-ation published on POST Technologies' Website.

A submitted FTTH Fibre Access Service FA-cancellation request shall contain all mandatory data as described in the above-mentioned documentation.

POST Technologies shall confirm a valid FAO_cancellation request by a XML message "FA_Cancelled" sent to the Operator within one (1) working day~~T1~~.

In case the time stamp of POST Technologies receiving the cancellation order from the Operator is later than the time stamp of sending an "FAO_Activated" message by POST Technologies to the Operator, POST Technologies will charge the full connection charge for that type of service as defined in Schedule 9~~Schedule 9~~Schedule 10.

If no information was available at the time of ordering on existing in-house cabling compatible with fibre-based services at the End User premises or if the available information given by POST Technologies was incorrect, the FTTH Fibre Access Service order may be cancelled free of charge until the time of installation and replaced with an MPF order, if a copper infrastructure is still operational at the End User premises.

3.7. Provisioning procedure of VULA Services

3.7.1. Ordering and provisioning

POST Technologies will provide to the Operator via its Website access to a regularly updated database as well as an online tool to check the feasibility and availability of the VULA Services for the End Users.

For VULA Services, POST Technologies' Website will also provide detailed information about the evolution of POST Technologies' P2P migration planning consisting mainly of

- (i) Sub-Loop Connection Point (SLCP)/Street Cabinet of the P2MP network currently serving the End User location;
- (ii) Fibre POP which the SLCP is currently connected to and where the VULA Services for the End User location will be delivered;
- (iii) Fibre POP to which the End User location will be connected after P2P transformation;

(iv) Planned completion dates for the P2P transformation of the SLCP

This information will allow the Operator to decide whether or not to purchase VULA Services at a specific Fibre POP.

When ordering a VULA Interconnection for a Fibre POP, this order has to be sent by the Operator to the following e-mail address

order.technologies@post.lu

and shall contain at least the following information:

- (i) Operator's name;
- (ii) Operator's contact point for this specific project including related e-mail address and telephone number;
- (iii) Address of the location/Fibre POP where the VULA Interconnection shall be provided;
- (iv) Interface to be used;

POST Technologies shall confirm within five (5) business days the receipt of every firm order for an VULA Interconnection and shall indicate an estimated ready for service date.

POST Technologies shall inform the Operator by e-mail as soon as the VULA Interconnections are ready for service on POST Technologies' side.

When ordering individual VULA Services, the exchange of information related to the ordering process for these services shall be done exclusively by means of a Web Service Application using the same interfaces which are already in use for Unbundled FTTH Fibre Access and Bitstream Service ordering.

An order will be rejected if it contains incomplete information or if the physical infrastructure is unavailable at the time of ordering (e.g. already unbundled to another operator).

The Operator may decide whether to carry out all installation services at the End User's premises by himself ("One Technician" method) or to ask for the installation service up to the ONT to be carried out by POST Technologies. When choosing the latter, the Operator will use the Booking Manager application provided by POST Technologies to choose an available time slot for the intervention of a POST Technologies technician.

When choosing the "One Technician" option, POST Technologies aims to complete any required installation works within the Fibre POP (e.g. patching) within a time period of 5 working days following the successful confirmation of an activation request.

As for Unbundled FTTH Fibre Access, the Operator may change his order to a copper-based Unbundling Service or Bitstream Service without any additional costs if he discovers on arrival at the End User's premises that compatible in-house cabling does not exist or cannot be installed.

The following table gives an overview of the lead times in relation with VULA Service fulfilment.

Order type	Lead time
Response time (validation/rejection) to a VULA Service activation request	1 Working Day
Earliest activation date (or booking manager slot) for a VULA Service following from the date of confirmation of a successful activation request	5 Working Days
Installation of a VULA Service with on-site intervention by POST Technologies' field technicians	95 % of all installations will be carried out on the due date as requested by the Operator
Time period for executing 95 % of all VULA requests under the "One Technician" program not requiring any modification of the physical access line apart from patching connections in the Fibre POP	5 Working Days
Time period for executing 95 % of change requests for VULA Services not requiring any modification of the physical access line nor any on-site intervention	5 Working Days
Implementation of a VULA interconnection	60 Working Days

[Using forecasts based on the amount of orders received during the previous 3-month period, POST Technologies aims to provide sufficient time slots for on-site interventions by POST Technologies' field technicians so as to accomplish 95% of all on-site VULA installations in less than 20 Working Days.](#)

[Urgent orders can be prioritized by using the available rush order process for guaranteed installation within a maximum of 2, 5 or 10 days \(cf. ~~Schedule 7~~Schedule-7\).](#)

[3.7.2. Cancellation of an order before activation](#)

[If an Operator wants to abandon its request for a VULA Service after submission of a formal order by the electronic messaging system, it shall send a cancellation request to POST Technologies in the form of an electronic message as described in the documentation published on POST Technologies' Website.](#)

[A submitted VULA Service cancellation request shall contain all mandatory data as described in the above-mentioned documentation.](#)

[POST Technologies shall confirm a valid cancellation request within one \(1\) working day.](#)

[If the order cancellation is received by POST Technologies not later than 16:00 of the last business day before the date of the intervention of the POST Technologies technician, POST Technologies will cancel the order and the Operator will be charged according to the tariff for cancellation of an order before activation as defined in ~~Schedule 9~~Schedule-9.](#)

[In case POST Technologies receives the cancellation later than 16:00 of the last business day before the date of the intervention, POST Technologies will cancel the order and the Operator will be charged the full installation tariff for a VULA Service as defined in ~~Schedule 9~~Schedule-9.](#)

[If no information was available at the time of ordering on existing in-house cabling compatible with fibre-based services at the End User premises or if the available information given by POST Technologies was incorrect, the VULA Service order may be cancelled free of charge until the time of installation and replaced with an MPF order, if a copper infrastructure is still operational at the](#)

End User premises.

3.7.3. VULA Decommissioning after ~~Point-to-Point~~ Network Transformation

Apart from the regular service cancellation which the Operator will transmit via the Web service interface, VULA Services will also have to be cancelled after a Fibre-SLCP providing part of the access circuit of the VULA Service has been converted from a point-to-multipoint into a point-to-point topology. The VULA Service, being a substitute product for unbundled point-to-multipoint FTTH Fibre Access Services, is provided only as a temporary solution while the transformation into a P2P network continues. In order to provide a continuous service to his End User, the VULA Service needs to be converted into a regular ~~Point-to-Point~~ FTTH Fibre Access Service.

When the infrastructure works required for the transformation of a SLCP or street cabinet from a P2MP into a P2P topology have been completed, any Operator with active VULA Services at this SLCP will be contacted in order to coordinate the works and interventions and to reduce the duration of the service outages during transformation.

The Operator will have to convert its VULA Services provided through this SLCP into an Unbundled Fibre Service. A pre-requisite for this is the presence of the Operator within the Co-location facilities of the Fibre POP in which the P2P connection will be terminated after transformation. While for some SLCPs the Fibre POP will remain unchanged, for others the P2P connections will terminate in a different Fibre POP.

For each SLCP transformation a detailed migration plan for all VULA Services will have to be established in close collaboration with the Operator. Depending on the quantity of subscribed VULA Services to be migrated to unbundled services at a new POP location, the migration plan may be adapted to suit the particular needs of the situation. A temporary re-routing to a centralized Bitstream RHD might be a solution, a temporarily provided VULA Service on the new P2P infrastructure might be another in order to decouple SLCP conversion from transformation of VULA Services into Unbundling Services which may also require on-site interventions at the End User's premises. On average, less than 10 VULA Services per Operator per SLCP are expected to be impacted by a single SLCP conversion. The temporary solutions should therefore be converted to the definitive unbundling services within approximately one month. Provisional intermediate configurations (e.g. re-routing to Bitstream RHD) will be delivered at no extra costs.

When converting VULA Services into Unbundling Services, the Operator can opt to acquire the ONT equipment installed at the End User site. This option will be available on a commercial basis and take into account the depreciation of the equipment.

3.10.3.8. Provisioning Procedure of FTTO Services

3.10.1.3.8.1. Quoting Process

Prior to any Operator ordering a FTTO Fibre Access Service, the availability of a spare fibre to the concerned FO-NTP has to be checked by POST Technologies.

For this purpose, the Operator shall submit a request by email to the following address: quote.technologies@post.lu, such request having to contain at least the following information:

- Operator's name;
- Operator's contact point for this specific project, including related e-mail address and telephone number;
- Concerned FO-NTP or exact End User's address.

POST Technologies will endeavour to reply to ninety-five percent (95%) of the valid survey requests received within fifteen (15) Working Days.

In case of a positive answer, POST Technologies will provide to the Operator a tailor-made offer with standard installation fees, standard monthly rental fee based on a price per km, and, as the case may be, transparent supplementary costs in order to deliver the FTTO Fibre Access Service at the earliest possible date.

Upon request, POST Technologies may provide a tailor-made offer for the internal cabling at the End User's premises as well.

With each request, a reservation of the available fibre will be made for 3 months.

3.10.2.3.8.2. Ordering

Any Operator's order for an FTTO Fibre Access Service has to be sent by the Operator to the following address: ordering.technologies@post.lu, and shall contain at least the following information:

- Operator's name;
- Operator's contact point for this specific project, including related email address and telephone number; and
- POST Technologies' reference of the answer to the concerned request; and
- POST Technologies shall confirm the receipt of every firm order for FTTO Fibre Access Services and indicate POST Technologies' target RFS date.

3.10.3.3.8.3. Hand-back Procedure

In case an End User terminates its services provided by the Operator through FTTO Fibre Access Services, this Operator shall inform POST Technologies thereof by sending an email to the following address: ordering.technologies@post.lu, which shall contain at least the reference number of the concerned FTTO Fibre Access Service.

POST Technologies shall confirm the termination by mail sent to the Operator within five (5)

Working Days~~T1~~.

The rental billed to the Operator for this FTTO Fibre Access Service shall be terminated at the due date indicated by the Operator. The indicated due date cannot be prior to the receiving date of the deletion message. If the indicated due date is not a Working Day, the first Working Day following the indicated due date will be taken into account.

In case of incoherence of the submitted mandatory hand-back information, this stated incoherence will be indicated in a reply message to the Operator.

The FTTO Fibre Access Service shall not be disconnected until the incoherence has been duly clarified with both Parties' best endeavors. The rental of the FTTO Fibre Access Service billed to the Operator shall continue until the FTTO Fibre Access Service can finally be effectively disconnected.

~~3.11~~3.9. Key Performance Indicators

POST Technologies will measure applicable Unbundling Services Key Performance Indicators (KPI) and inform the ILR in compliance with Regulation ~~14/180~~/ILR/T19/1 from 13th March 2019.

~~3.12~~3.10. Non-standard Requests

In case of non-standard requests related to Unbundling Services which demand either a feasibility study including a detailed analysis of the Operator's requirements as well as an evaluation of the technical and financial aspects of a tailor-made implementation and the potential impact on processes and operations or any other special requests, POST Technologies will bill the supplementary efforts on an hourly basis as defined in ~~Schedule 9~~Schedule 9~~Schedule 10~~ and will, subject to the outcome of the feasibility study or its assessment, make its best efforts to conclude an agreement with the Operator within a maximum of 3 (three) months after receiving from the Operator all the information required.

Schedule 4. Fault Repair

4.1. Fault Reporting and Repair

4.1.1. Generalities

Prior to submitting a Fault Report, the Operator shall have to ensure that a genuine fault exists and that every effort has been made in advance to check that the fault resides within POST Technologies' area of responsibility.

4.1.1.1. POST Technologies FCP and Operator FCP

The Operator shall send a Fault Report to POST Technologies FCP (Fault Contact Point) at the following email address:

bo_acc_derBO_ACC_DER@post.lu.

In case of a MPF, FTTH, FTTO or VULA Service covered by a Business SLA (cf. ~~Schedule 6~~Schedule 6), e-mails should be sent to

noc@post.lu

for immediate handling of the fault ticket.

Upon receipt of a valid Fault Report compliant to the minimum terms set forth in points ~~4.1.2.14-1.2.1~~ below, as applicable, POST Technologies shall send an e-mail to the Operator to inform it first of the Incident Ticket Opening and last of the Incident Ticket Closing.

To do so, the Operator shall provide POST Technologies with an e-mail address for the exchange of such notification messages.

~~All related phone calls should be directed via the POST Technologies FCP: +352 4991 5868.~~

~~Phone number outside business hours: 1 24 24~~

Operator's Fault Reports may be addressed to POST Technologies 24/7.

In case of a fault occurring to any service supplied by and under control of POST Technologies, POST Technologies shall commence to resolve the fault within the time frame as defined in Schedule 11 after Incident Ticket Opening. POST Technologies attempts to achieve service restoration for 95% of one Operator's validly submitted Fault Reports for services not covered by a Business Service Level Agreement during the business day following the acceptance of a valid Fault Report, while either the concerned fault and/or the restoration delay are within POST Technologies' sole responsibility.

To be valid, a Fault Report shall contain the minimum information and data requested in the below paragraphs according to the Services concerned.

Expenses incurred for the repair will be charged to the Operator.

Any unplanned intervention that caused damages to facilities must be reported to the POST Technologies staff in charge who will judge, whether it is necessary to monitor installation works going forward.

~~In case of a damage to several ducts and cables, POST Technologies will coordinate the repair of ducts so that Operators can install their sub-ducts, micro-tubes or cables for repair.~~

POST Technologies' intervention on faults shall be strictly limited to POST Technologies Infrastructure. In no case POST Technologies will undertake any fault clearance on the Operator's infrastructure, including the Operator's segments used to access POST Technologies Infrastructure.

~~In case of a fault on a DSS caused by POST Technologies, POST Technologies will re-establish end-to-end connectivity of the DSS between the access points at its own costs and will arrange, if necessary, with the Operator the reactivation of its services.~~

~~In case of a fault on a DSS located within POST Technologies' area of responsibility, caused by a third party, POST Technologies will re-establish end-to-end connectivity of the DSS between access points. All other aspects regarding the reestablishment of Operator's services have to be initiated and controlled by and under the Operator's sole responsibility.~~

4.1.1.2. Fault clearance interventions

Fault clearance will be performed during Business Hours.

Special conditions and tariffs apply for fault clearance outside Business Hours.

Fault clearance interventions are billed by POST Technologies to the Operator as defined in ~~Schedule 9~~[Schedule 9](#)~~Schedule 10~~.

Fault reporting and repair have to be performed and achieved in compliance with the specific terms, conditions and time schedules specified per type of service in the related paragraphs below.

Upon receipt of a valid Fault Report, POST Technologies will confirm the due receipt thereof and the starting of POST Technologies' fault clearance intervention in relation thereto by sending an Incident Ticket Opening to the Operator.

For the avoidance of doubt:

- (i) only Fault Reports confirmed by an Incident Ticket Opening will be treated; and
- (ii) the time computation relating to POST Technologies' SLA shall start to count as of the date and time of the Incident Ticket Opening and end at the date and time of the related Incident Ticket Closing as specified in detail in chapter ~~4.1.24~~[4.1.24](#)~~4.1.2~~.

4.1.1.3. Wrongful repair request

A wrongful Fault Report occurs when POST Technologies has done all necessary measurements on the line and test results prove that the quality of the service concerned by the Fault Report is not the cause of service interruption or service degradation.

In case the reported fault does not lie within the scope of POST Technologies' responsibility for the concerned part(s) of the Services under this RUO or in case of a

wrongful Fault Report, all the costs related to works and travelling already performed by POST Technologies in relation to such Fault Report will be charged to the Operator.

4.1.1.4. Feedback on requested repair

In case the Operator contacts POST Technologies in writing about an ongoing repair action related to a Fault Report, POST Technologies will inform the Operator of the current repair status of the said fault. Upon Operator's express request, a report confirmation will be sent by fax or by e-mail.

4.1.2. Fault reporting and repair for MPF, ~~FTTHA~~, FTTO and VULA Services and ~~DSS~~

4.1.2.1. Fault reporting to POST Technologies by the Operator

Fault Reports affecting the MPF, FA, FTTO or ~~VULA~~~~DSS~~ will be exchanged between the Operator's FCP and POST Technologies' FCP.

The Operator shall provide sufficient information with each Fault Report to allow the diagnosis of the reported fault and to enable the progression of the fault until resolution. Therefore, all Fault Reports should be done using the Service Portal by filling in all the required elements. ~~a predefined fault report form that can be downloaded from POST Technologies' Website, and fulfil all items referred to in the said form.~~

Fault Reports are nevertheless also accepted via simple e-mail containing at least the following data:

1. POST Technologies' reference number of the disturbed Services and precise type of Services affected;
2. Contact point and phone number of the concerned End User, unless the Operator does not approve of POST Technologies entering into direct contact with the End User. In this case the Operator indicates its own contact point and phone number for further investigations;
3. Full address of the concerned End User;
4. Operator's contact point (including phone and fax numbers as well as e-mail address) for the given Fault Report and related fault clearance;
5. If applicable, specification that the Service(s) affected are covered by a Business SLA and the reference thereof;
6. Precise description of the reported fault; and
7. Date and description of the intervention of the Operator's technician, including the result of an attenuation measurement between the Operator's connection point and the NTP/FO-NTP.

The Operator may pass any additional information it considers relevant to the Fault Report while POST Technologies shall not be obliged to use such additional information, whichever may be the reason.

Upon receipt of a valid Fault Report, POST Technologies will send an Incident Ticket

Opening to the Operator as well as afterwards the Incident Ticket Closing. This automatically sent notification messages are triggered by the POST Technologies' reference number of the line. If this field is not indicated in the Operator's Fault Report, no Incident Ticket Opening will be sent to the Operator, while the concerned Fault Report will be deemed as invalid.

4.1.2.2. Fault reporting to POST Technologies by the End User

The Operator has to inform the End User about the Operator's responsibility and timely communicate the Operator FCP to the End User in order to prevent any abuse of POST Technologies' support services.

POST Technologies will not accept any Fault Report from the Operator's End Users. POST Technologies has no obligation to report to the Operator a fault that an End User would have directly reported to POST Technologies.

4.1.2.3. POST Technologies and Operator liabilities for the fault clearance

The Operator is requested to transmit to POST Technologies all measurement data from tests the Operator has already performed on MPF, FTTHA, FTTO or VULADSS.

These measurements should include, if applicable, the following items:

- Resistance measurements,
- Capacity measurements,
- Attenuation
- In case the Operator encounters problems on xDSL services offered through an MPF line, the following additional information is required:
 - DSL line synchronised or not synchronised,
 - PPPoE OK or not OK,
 - DSL bit rate values up/down,
 - Noise margin.

If requested by POST Technologies, the Operator shall disconnect the terminal equipment at the End User's site in order to allow the testing of the MPF, FTTHA, ~~or~~ FTTO or VULA Services. POST Technologies can also request to the Operator a timeframe for isolating the MPF, FTTHA, ~~or~~ FTTO or VULA Service in the Operator's Co-Location facilities to do the necessary measurements.

Any Operator's refusal to timely comply with such request will prevent POST Technologies from verifying the concerned Services and the related Fault Report will be deemed as being wrongful. Both parties shall co-operate in good faith to find suitable timings.

If the Operator's Fault Report received by POST Technologies is valid and contains all minimum information requested, POST Technologies will issue an Incident Ticket Opening and starts fault localisation and fault clearance process during normal working hours. Upon detection of a fault on the MPF, FTTHA, ~~or~~ FTTO or VULA Service, POST Technologies will use all reasonable endeavours to repair the fault as soon as reasonably practicable.

~~95% of all The~~ fault clearance is to be achieved within ~~one (1) Working Day~~~~F40~~. The applicable tariffs are specified in ~~Schedule 9~~~~Schedule 9~~~~Schedule 10~~.

The Operator shall cooperate with POST Technologies' reasonable requests in an effort to locate and if possible resolve any fault. In case contact with the End User is necessary for fault location and/or restoration, POST Technologies reserves the right to contact and make an appointment with the Operator's End User for the repair of the MPF, FA, FTTO or ~~VULAS~~ Services if the Operator has submitted the related End User contact information in its Fault Report. In case no such information was provided, POST Technologies will contact the Operator using the contact information provided in the Fault Report in order to fix an appointment at the End User's premises for further investigation and fault resolution. The time elapsed between the contact with the Operator and the scheduling of an appointment will not be considered for the fault repair time computation.

When POST Technologies has sufficient technical proof that the fault has been cleared an Incident Ticket Closing will be sent to the Operator. The Operator may challenge the closing of ticket within ~~twenty-four (24)~~ working hours. POST Technologies may give the ticket a different status within their systems. Except if the Operator rejects the concerned Incident Ticket Closing within ~~twenty-four (24)~~ working hours after receipt, the Incident Ticket and the related Fault Report will be closed automatically by POST Technologies.

Any Incident Ticket Closing of POST Technologies will contain detailed information on the fault and the resolution.

If the Operator rejects the Incident Ticket Closing as specified above, it shall specifically provide the following information:

- The reason why the Operator reasonably believes that the circuit is unsuitable for use as a MPF, ~~FTTHA~~, FTTO or ~~VULADS~~ Service,
- Whether or not the Operator believes that the MPF, ~~FTTHA~~, FTTO or ~~VULADS~~ Service is within the agreed specifications,
- All additional information that the Operator reasonably considers suitable to assist in understanding and diagnosing any underlying fault in the MPF, ~~FTTHA~~, FTTO or ~~VULADS~~ Service.

The Operator must cooperate with POST Technologies to carry out further tests, even on Operator's equipment when reasonably requested to do so. POST Technologies may carry out additional works upon the Operator's request and approval, while the costs thereof shall be invoiced to the Operator, only in case of a wrongful repair request.

Both Parties recognize and acknowledge that the fault repair time will commence when POST Technologies issues the Incident Ticket Opening and will end with the Incident Ticket Closing, if it is not rejected by the Operator.

4.2. End Users' liabilities

The Operator shall ensure that the concerned End User(s) will timely grant POST Technologies' technician access to the NTP/FO-NTP within his/her premises as often as this is necessary for the clearance of the concerned fault. In case of any problems, POST Technologies will report this to the Operator, who will have to contact forthwith the End User and take the necessary arrangements to grant access to POST Technologies.

In case the End User is absent during POST Technologies' technicians' visit, POST Technologies will leave a card in the mailbox requesting the End User to contact POST Technologies' helpdesk to schedule an appointment. In such case, the normal intervention periods cannot be respected and the intervention time computation shall be automatically suspended until the End User contacts POST Technologies' helpdesk and an arrangement has been achieved for a new visit.

Schedule 5. Quality of Service - Service Level Agreement (SLA)

Within the frame of this RUO, POST Technologies offers the following service level parameters for the MPF, ~~FTTHA~~, FTTO and ~~VULADSS~~ Services.

POST Technologies offers two different service levels for the Services, i.e.:

- a Standard service level ("Standard SLA"), which applies for any Services to be provided under this RUO without additional fee to be paid for by the Operator, and
- a Business service level ("Business SLA"), which may be specifically opted in by the Operator per Service for the benefit of professional End Users, while any such option shall lead to the application of the corresponding Business SLA fees as set forth in ~~Schedule 9~~~~Schedule 10~~ and ~~Schedule 6~~~~Schedule 6~~ attached hereto.
- If an Operator wants a higher level of service for a particular Service (Premium Service Level Agreement), POST Technologies has to provide upon written request of the concerned Operator a draft offer for the specific SLA as required by the Operator, which shall be in line with POST Technologies' network technical specifications and capabilities. This offer shall be submitted, with the details about POST Technologies' network and capabilities, to the Operator and to the ILR, which shall accept or amend the proposition of POST Technologies, after consultation of both POST Technologies and the requesting Operator.

Schedule 6. Business SLA

6.1. Definitions related to the Business SLA

The following definitions apply to the SLA in relation to the LLU Services.

6.1.1. Business SLA Agreement

The specific agreement specifying all procedures, contact points, terms and conditions for LLU Services specifically covered by a Business SLA at the express Operator's option, to be entered into by and between the Parties in case the Operator wants to opt in for Business SLA, it being specified that:

- (i) a Business SLA agreement may only be entered into by the Parties provided the concerned Operator has prior entered into an Unbundling Agreement as specified in POST Technologies' RUO in force
- (ii) in case the Parties already entered into a Unbundling Agreement prior to the entry into force of this RUO, the Business SLA Agreement that the Operator will further execute shall automatically amend the said Unbundling Agreement.

6.2. Terms and conditions of the Business SLA

The Business SLA Agreement shall be provided for a minimum one (1) year lease period. After expiry of this 1st year, the Operator may terminate the Business SLA Agreement upon a one (1) month prior written notice.

In any case, the minimum duration for the Services to be specifically covered by a Business SLA is one (1) month.

The applicable contact points and detailed procedures be complied with any Fault Report related to Services covered by a Business SLA are specified in the Business SLA Agreement.

The intervention window is 24/24 hours and 7 days/7.

The applicable fees are as follows:

	Business SLA
SLA Business monthly lump sum fee covering up to 100 circuits in addition to the monthly fee for each Service concerned <u>allowing access to Business Service Level ordering for MPF, FTTH, FTTO and VULA Services</u>	<u>12.000,-</u> EUR
Business SLA - A <u>activation fee per 1 MPF, or FTTH or VULAA Service</u>	9,- EUR
Business SLA - Monthly rental fee per 1 MPF, or <u>FTTH or VULA Service</u> in addition to (i) the monthly fee as from the first circuit concerned and (ii) the monthly fee applicable for the concerned Service.	9,- EUR
Business SLA - A <u>activation fee per 1 FTTO Service</u>	100,- EUR
Business SLA - Monthly rental fee per 1 FTTO Service in addition to (i) the monthly fee as from the first circuit concerned and (ii) the monthly fee applicable for the concerned Service.	<u>2550,-</u> EUR

For the avoidance of doubt, the terms and conditions of a Business SLA shall only apply provided the Fault Report in relation to a fault concerning LLU Services covered by a Business SLA:

- (i) contains all required minimum information as applicable to the type of LLU Service(s) concerned,
- (ii) expressly specifies the term "SLA" in the subject line of the Fault Report email,
- ~~(iii) expressly specifies the reference number of the concerned Business SLA, and~~
- ~~(iv)~~ (iii) has been submitted to POST Technologies' contact point as specified in the Business SLA Agreement.

Fault clearance under Business SLA conditions will be free of charge for the Operator independent on the Intervention Time, provided the fault reported in the Fault Report duly lies within the section of the Service for which POST Technologies is responsible. In case the fault lies outside the section of the Service for which POST Technologies is responsible, the tariffs as specified in ~~Schedule 9~~ Schedule 9 ~~Schedule 10~~ will be charged to the Operator.

Any fault validly reported by the Operator shall be deemed as duly cleared if the Operator fails to reject the related Incident Ticket Closing submitted by POST Technologies within twenty-four (24) hours after receipt thereof.

6.3. Business SLA fault reporting and repair

Faults regarding LLU Services covered by a Business SLA have to be reported to a special FCP and in compliance with the procedures defined in the Business SLA Agreement.

Both Parties recognize and acknowledge that the Intervention Time shall commence when POST

Technologies issue the Incident Ticket Opening relating to the validly received Fault Report.

6.4. Business SLA characteristics

6.4.1. MPF, ~~and FTTH~~ and VULA Services

	Business SLA
Intervention Time	4,5 hours
Call-back Delay	0,5 hour

6.4.2. FTTO Services

	Business SLA
Intervention Time	4,5 hours
Call-back Delay	0,5 hour

6.5. Penalties

In case POST Technologies does not conform to a given Business SLA and provided the conditions applicable thereto as set forth in the applicable RUO have been duly complied with, a Penalty shall be paid by POST Technologies, upon Operator's written express valid request, per concerned LLU Services covered by a Business SLA on the following basis.

6.5.1. MPF, ~~and FTTH~~ and VULA Sservices

Intervention Time (I)	Penalty
$I \leq 4,5h$	0
$4,5h < I \leq 8h$	40 EUR
$8h < I$	80 EUR

6.5.2. FTTO services

Intervention Time (I)	Penalty
$I \leq 4,5h$	0
$4,5h < I \leq 8h$	1 monthly fee recurring cost
$8h < I$	2 monthly recurring cost fees

Schedule 7. Rush Orders

An Operator may ask for a rush order for [MPF, FTTH and VULA Services Unbundling Services](#) (~~MPF new line, MPFNP swap or FA services~~) under the condition that the Operator has first submitted a valid survey request for this line to POST Technologies and that POST Technologies has positively replied to this request. POST Technologies' shall reply to the Operator's survey request within one (1) Working Day for requests received through the [Web service interface](#). ~~XML/SOAP procedure.~~

After reception of a ~~XML/SOAP~~ message "survey success" the Operator should reply to POST Technologies by sending a "rush order" as defined in the applicable documentation on POST Technologies' Website. Every Operator has the right to submit up to three (3) rush orders per month to POST Technologies. Every other submission of a rush order is subject to the availability of POST Technologies' workforce. [Orders for FTTO Fibre Access Services are often based on tailor-made quotes which require additional works in the network \(e.g. splicing\) to deliver the requested service. The ordering process is currently not handled via the Web service interface, but rush order requests will also be accepted for these services at the time of ordering. In case of feasibility and if no additional works have to be carried out in the network, the same rush order conditions are applicable to FTTO services as are to MPF, FTTH and VULA services.](#)

[POST Technologies offers 3 types of Rush Orders:](#)

- (i) [Type 1: Activation within 2 Working Days after the related Rush Order request has been received by POST Technologies](#)
- (ii) [Type 2: Activation within 3 and 5 Working Days after the related Rush Order request has been received by POST Technologies](#)
- (iii) [Type 3: Activation within 6 and 10 Working Days after the related Rush Order request has been received by POST Technologies](#)

~~A valid rush order should be executed by POST Technologies in a time frame of S+8WH and S+24WH, where "S" is the date and time of the receipt by POST Technologies of a rush order submitted by an Operator and "WH" are the Working Hours which should be counted from Monday to Friday between 8:00 and 12:00 to and 13:00 to 17:00.~~

The Operator may propose an appointment within the before mentioned time frame which POST Technologies should respect under the condition that POST Technologies labour force is available at the proposed time. If that is not the case, POST Technologies will fix another appointment within the same timeframe.

POST Technologies will reply to the Operator's rush order request within a timeframe of [4foru Working Hours](#). ~~"S+4WH"~~. The message will contain the definitively retained date and time of the rush order appointment.

Rush order installations will only be executed during normal working hours, that is from Monday to Friday between 8:00 and 12:00 to and 13:00 to 17:00.

The Operator has to assure that the End User is informed of the exact date and time of the rush order installation, that access, [if required](#), to the network termination point (NTP or FO-NTP) is

guaranteed and that the internal cabling at the End User's premises is ready. If the installation cannot be executed by POST Technologies' staff, for reasons beyond POST Technologies' control (e.g. End User's absence, no access to the NTP or FO-NTP, internal cabling not ready) despite the appointment fixed with the End User, the rush order will be stopped and POST Technologies will duly report the stop of the rush order to the Operator. The order should in this case be executed as normal unbundling order after the Operator has fixed a new appointment on a free available time slot on the booking manager. The supplementary costs of the rush order will be charged to the Operator as defined in [Schedule 9Schedule-9Schedule-10](#).

In case of serious doubt, the Operator may request proof of the effective need for the rush order stop, and POST Technologies will respond to that request within one (1) Working Day.

All rush order installations will be charged to the Operator as defined in [Schedule 9Schedule-9Schedule-10](#)- Tariffs.

Schedule 8. ~~How to transmit the "Demande de raccordement souterrain"~~ Request for an Underground to POST Technologies by the Operator, Connection on behalf of the End User

8.1. Request

A standard form for an connection to POST Technologies' underground copper and/or fibre network ("Demande de raccordement souterrain") is available on POST Technologies' Website or at the Operator's simple request.

The Operator signs on behalf of the End User a duly completed form and transmits it to POST Technologies, provided that the Operator has been effectively mandated by the End User in this respect. The Operator will explicitly indicate in a document to be signed by the End User that charges will be due for the realisation of the "raccordement souterrain" (underground connection).

The Operator is not obliged to provide automatically POST Technologies with a written proof of the mandate when transmitting a signed and completed "Demande de raccordement souterrain". However, the Operator will provide POST Technologies with a written proof at POST Technologies' simple request.

8.2. Invoicing

Within a delay of five Working Days (5) days after the day of receipt of the "Demande de raccordement souterrain", the End User on behalf of whom the Operator has transmitted to POST Technologies the request, will receive a letter from POST Technologies indicating the charges for realising the "raccordement souterrain" according to its price list in force, unless a site survey is required in order to propose a tailor-made quote for the requested underground connection.

8.3. End User contact for the realisation of the "raccordement souterrain"

Within a delay of fifteen (15) days after the day of receipt of the "Demande de raccordement souterrain", POST Technologies' Fixed Infrastructures Department will contact the End User directly in order to realise the "raccordement souterrain".

Before the actual beginning of the "raccordement souterrain", the End User will be required to confirm its consent to the applicable charges, as indicated in the letter within the meaning of paragraph 8.28.2 above.

~~Schedule 9. Access to POST Technologies's End User account numbers~~

The POST Technologies "account number" and the POST Technologies "customer number" are indicated on every POST Technologies' monthly telephone bill.

This information can also be accessed by End Users and Operators through a special search engine published on POST Technologies' Website covering Operator services in the unprotected area of POST Technologies' Website.

To obtain the required information the phone number and the date of birth of the account owner have to be provided:

If the provided data match the data stored in POST Technologies' database, the search engine will provide the "account number" and the "customer number" of the account owner.

If the combination of the provided information does not match, the search engine will return the message "Phone number and date of birth do not match, please check your data before trying again"

If the phone number submitted does not exist in POST Technologies' database (e.g. the number has already been ported to another operator), the search engine will indicate the message "Phone number does not exist in POST Technologies database"

If the provided phone number exists but no data regarding the birthday of the account owner is available in POST Technologies' database, the search engine will indicate the message "Date of birth not available in POST Technologies' database, please contact POST Technologies no.8002-8004". In this case the Operator or the End User can request the required information by phone. The account and customer number information will be transmitted by POST Technologies after receiving by fax (no.: 8002-8005) a copy of the account owners identity card.

If the phone number provided is not stored in POST Technologies database as an number for residential customers, the search engine will indicate the message "You are not listed as a residential customer in POST Technologies database"

~~Schedule 10.~~ **Schedule 9. Tariffs**

This schedule presents the specific tariffs applicable to [this RUO Services](#).

[These tariffs are only applicable to all services with a minimum contract duration of 6 months.](#)

~~10.1.~~ **Fibre Tie cables**

Item	Euro
Connection charge for RCFs with 24 fibres Area POP type B)	1.179,-
Connection charge for RCFs with 48 fibres Area POP type C)	2.358,-
Monthly charge for RCFs — per 24 fibres	3,17

9.1. FTTH Fibre Access Service (FA Service)

~~10.2.~~

Item	Euro
Migration of an existing ORATH or ROB service to an FA (using the same fiber)	62,06
Connection charge for a new or modified FTTH Fibre Access connection not requiring any intervention at end customer's premises	77,84
Connection charge for a new or modified FTTH Fibre Access FA connection and measurement, <u>intervention</u> at ODF and <u>end at</u> customer's premises, including travel <u>costs</u> <u>sling</u>	124,13
Migration of an existing FTTH Fibre Access from Donor to Recipient Operator not requiring any intervention at end customer's premises	85,84
Conversion of an existing VULA or fibre-based Bitstream Service to a FTTH Fibre Access Service not requiring any intervention at end customer's premises	7785,84
Conversion of an existing VULA or fibre-based Bitstream Service to a FTTH Fibre Access Service requiring an intervention at end customer's premises, including travel costs	124,13
Monthly rental for a FTTH Fibre Access SA-service	19,007,75
Monthly rental for a FA sub-loop service	17,75
Monthly rental for a Back haul fibre link in the context of FA sub-loop services	Free of charge
Connection charge for a Back haul fibre link in the context of FA sub-loop services	Free of charge
Costs of a Rush order	250,-
Training course for the fibre management and installation works at the FO-NTP	300 ¹ ,-

¹ This training strives at preparing the operator's own technicians to connect their own fiber access lines for their end-user under the prevailing RUO. The aim is for every operator to install a fiber line without the intervention of any EPT technician. The basic training consists of getting familiar with the technical constraints and guidelines, the security measures, the quality of the work to be performed, various configurations and procedures and fault detection. Complying with technical principles and following the rules is mandatory in order to maintain the integrity of the network and the quality of the service.

The training is supported by various illustration and pictures to facilitate comprehension. The broad lines that will be covered in this training are the following (not exhaustive) :

- Which types of cables to be used
- What network connector types to be used
- Pigtail cleaning
- What kinds of pigtails to use in what cases and how to use them
- Measurement of loss of signals
- Configurations of ONT's

Negative answer to an FTTHFA order* or cancellation of an order before activation	15,51
FTTH Fibre Access A Hand-back charge	16,32,-
FA Migration	145,33
FA Wrongful Repair Request	Actual costs based on the actual man power fees
POST Technologies manpower for special works required by the Operator – per hour	See paragraph 10.4

*Only applicable in case POST Technologies' search engine showed clearly that the specific address is not yet served by POST Technologies' [point-to-point](#) FTTH network.

- Different types of in-house cabling
- Illustration of different boxes in old and new buildings and how to deal with special cases
- Multi-End-User building FO-NTP configuration
- Procedures for connections with splicing
- Secure sealing with cable ties,
- Connections in POP's
- Fault localization and according to what scenario the corresponding solutions

9.2. VULA Service

<u>Item</u>	<u>Euro</u>
<u>Connection charge for a new or modified VULA connection carried out remotely without any intervention at POP or SLCP level or at end customer's premises</u>	<u>10,79</u>
<u>Connection charge for a new or modified VULA connection, intervention only at POP or SLCP level, -not requiring any intervention at end customer's premises</u>	<u>77,84</u>
<u>Connection charge for a new or modified VULA connection, intervention -and measurement at ODF and end customer's premises, including travel costs</u>	<u>124,13</u>
<u>Migration of an existing VULA Access from Donor to Recipient Operator carried out remotely without any intervention at POP or SLCP level or at end customer's premises</u>	<u>16,91</u>
<u>Conversion of an existing point-to-multipoint fibre-based Bitstream Service to a VULA Service carried out remotely, not requiring any intervention at end customer's premises</u>	<u>10,79</u>
<u>Conversion of an existing VULA Service into a FTTH Fibre Access Service after P2MP => P2P network/SLCP transformation not requiring any intervention at end customer's premises</u>	<u>77,84</u>
<u>Conversion of an existing VULA Service into a FTTH Fibre Access Service after P2MP => P2P network/SLCP transformation requiring an intervention at end customer's premises, including travel costs</u>	<u>124,13</u>
<u>Monthly rental for a VULA Service</u>	<u>20,1018,85</u>
<u>Connection charge for a VULA Interconnection (per Local Exchange/Fibre POP)</u>	<u>1.400,-</u>
<u>Monthly rental of a 10GE VULA Interconnection (per 10GE port)</u>	<u>13,30</u>
<u>Monthly rental of a 100GE VULA Interconnection (per 100 GE port)</u>	<u>41,78</u>
<u>Negative answer to an VULA order* or cancellation of an order before activation</u>	<u>15,51</u>

*Only applicable in case POST Technologies' search engine showed clearly that the specific address is not served by POST Technologies' point-to-multipoint FTTH network.

~~10.3.9.3.~~ FTTO Fibre Access Service

Item	Euro
Connection charge FTTO - connection and measurement at ODF and at End User's premises including travelling	720,-
Monthly rental for a FTTO service	48,- per km Up to a maximum of 288,-€ per FTTO service ^{*)}
Training course for the fibre management and installation works at the FO-NTP	300 ² ,-
Survey + Request for quote and reservation of fibre for a duration of 3 months (per fibre)	120,-
Site survey	140,-
FTTO Hand-back charge	32,-
FTTO Wrongful Repair Request	Actual costs based on the actual manpower fees
POST Technologies manpower for special works required by the Operator – per hour	See paragraph 10.4

^{*)} Sites connected by the FTTO network are mostly connected to more than one Local Exchange in order to allow for redundant setups. The price cap as mentioned before, which equals to a maximum billed length of 6 km (6km*48€/km =288€), is only valid if the FTTO Fibre Access Service terminates within the nearest Local Exchange or within a Local Exchange proposed by POST Technologies. If the Operator for some reason chooses a different Local Exchange (e.g. diverse routing, no colocation presence), the entire fibre length will be billed if it exceeds the length of 6 km.

Please also note that a minimum length of 1 km will be invoiced even if the actual fiber length is only a fraction of one km.

~~10.4.1.1. Actual POST Technologies Manpower fee – per hour~~

~~All actual manpower fees are published on POST Technologies Website.~~

~~10.5. Copper tie cable~~

Item	Euro
Connection charge for tie cables – per 100 pairs	2.053,54
Monthly charge for tie cables per 100 pairs	3,17
POST Technologies manpower for special works required by the Operator – per hour	See paragraph 10.4

² Cf. Note 1

10.6.9.4. Metallic Path Facility (MPF)

~~(SAME CHARGES FOR MPF combined with NP)~~

Item	Euro
Migration of an existing RDSLO or or ROB service to an MPF (using the same copper pair)	53,12
Survey charge for a non-active local loop including length provisioning in case of no firm order	27,59
Survey charge for an active local loop including length provisioning in case of no firm order	15,51
Connection charge MPF including survey charge - non-active local loop	106,91
Connection charge MPF including survey charge - active local loop	53,12
Costs of a Rush order	250,-
Monthly rental MPF	
From 01/11/2018 to 31/12/2018	8,26
From 01/01/2019Up to 31/12/2019	8,43
From 01/01/2020_on	8,60
Monthly rental SLU	
From 01/12/2018 to 31/12/2018	5,25
From 01/01/2019Up to 31/12/2019	5,34
From 01/01/2020_on	5,44
MPF Hand-back charge	19,37
Re-activation of a ceased MPF	18,24
MPF loop resistance measurement	179,29
MPF order cancelled before activation	7,84
MPF Wrongful Repair Request	183,85
POST Technologies manpower for special works required by the Operator – per hour	See paragraph 10.4

9.5. Rush Order Fees for MPF, FTTH, FTTO and VULA Services

<u>Item</u>	<u>Euro</u>
Rush Order type 1 (within 2 Working Days)	1.000,-
Rush Order type 2 (within 5 Working Days)	750,-
Rush Order type 3 (within 10 Working Days)	500,-

9.6. Fault Repair Fees for MPF, FTTH, FTTO and VULA Services

<u>Item</u>	<u>Euro</u>
During business hours (8:00 – 17:00), fault in POST Technologies' Network	Free of charge
During business hours (8:00 – 17:00), fault in the Operator's Network	Invoiced per hour
Priority intervention Monday to Friday 7:00 – 19:00, Saturday 8:00 – 12:00, fault in POST Technologies' or the Operator's Network	Invoiced per hour Min. 250,- EUR per intervention^{*)}
Priority intervention Monday to Friday 19:00 – 7:00, Saturday 0:00 – 8:00 and 12:00 – 24:00, Sundays and public holidays, fault in POST Technologies' Network or the Operator's Network	Invoiced per hour Min. 500,- EUR per intervention^{*)}

^{*)} Minimum charge will not apply if the Operator has chosen the Business Service Level for its MPF, FTTH, FTTO or VULA Service

9.7. ~~Actual~~ POST Technologies Manpower Fee – per hour

[The current ~~All actual~~ tariffs for manpower fees are published on POST Technologies Website and will be applied in case of carrying out additional works requested by the Operator, but not covered by any of the aforementioned fixed price services.](#)

~~10.7. Duct Sharing Services (DSS)~~

<u>Item</u>	<u>Euro</u>
Survey request	350,84
Connection charge for a DSS	Actual costs based on the actual man power fees
Monthly rental for a DSS (30 mm inside diameter) per meter	0,11/m/month
POST Technologies manpower for special works required by the Operator—per hour	See paragraph 10.4

Schedule 11. Parameter Schedule

11.1. Provisioning of MPF

Timer	Value	Description
T1	5 Working Days	Response time to the survey request
T2	20 Working Days	Maximum time period for MPF reservation as from the date the positive survey request has been send by electronic mail
T3	3 Working Days	Time period between the date the positive survey has been send by electronic mail and the date the Operator submits a firm activation order for the MPF
T4	5 Working Days	Delivering by Operator to POST Technologies of the original MPF request form signed by the End User in case of doubt
T5	2 Working Days	Order cancellation before agreed appointment date for installation of the service
T6	5 Working Days	Time period to submit an alternative solution in case the reserved resources in POST Technologies' network are not usable to provide MPF
T8	2 Working Days	Time period as from the moment service has been terminated to inform POST Technologies that MPF has become available for re-use
T9	2 Working Days	Confirmation by POST Technologies to hand-back message or Cancellation of Order before activation time period to provide the hand-back message to POST Technologies

11.2. Provisioning of tie cables

Timer	Value	Description
T30	35 Working Days	Provision of ordered tie cables

11.3. Fault Reporting and Repair

Timer	Value	Description
T40	1 Working Day after the issuance day of a Fault Report	Time period to achieve 95% of fault repair requests.
T41	4,5 hours as from the Incident Ticket Opening	Time period to be complied with in case of Business SLA.

11.4. Other

Timer	Value	Description
T50	4 Working Days	Notification period for appointments sent to POST Technologies
T51	5 Working Days	Provision of an internet address and password to the Operator to access the MDF information
T52	20 Working Days	Maximum period between the declaration of an Operator that it is interested in Local Loop Unbundling Services and the acceptance of first electronic exchanged file