



Reference Unbundling Offer

Entreprise des Postes et Télécommunications

01/01/2009 – 31/12/2010

Prices in Euro

DOCUMENT SUBMITTED TO APPROVAL TO ILR AND NOT APPROVED BY ILR

Date	Status
22.10.08	Version dated October 08 transmitted to ILR for review and approval.
11.12.08	Version updated further to ILR's request dated 04.12.08 to amend in schedule 5 (i) point 5.2.3 "Operators' information in case of failure" of the RUO 2007-2008, applied <i>mutatis mutandis</i> to this draft RUO 2009-2010 as well as (ii) point 5.4 "Mixture of CO and RT deployments".
21.01.09	Version updated further to include BFL services in point 2.6.4.1 and related schedules.
19.02.09	<i>Version adapted with a special reference to the document "xDSL Network Downstream Power Backoff Definition for Luxembourg" in schedule 5 point 5.4</i>
20.03.10	<i>Version updated further to ILR's request dated February 2010</i>
27.05.10	<i>Version updated further to ILR's request dated 20.04.2010</i>
05.08.10	<i>Version updated further to ILR's request dated 26.07.2010</i>
20.10.10	<i>Version updated further to ILR's request dated 18.10.2010 (2.6.1. Backhaul Connections in the context of SLU – Generalities)</i>

Table of content

1	Introduction	4
1.1	Purpose	4
1.2	Services covered	4
1.3	Minimal terms	5
1.4	No content liability	5
1.5	Term	5
1.6	Amendments	5
1.7	Interpretation rules	5
1.8	Prices	6
2	Definitions	7
3	The RUO Principles	12
3.1	Service Description	12
3.2	Responsibilities	13
3.3	EPT's General Power	15
3.4	Quality of Service – Service Level Agreement (SLA)	17
3.5	System protection	23
3.6	Configuration and technical constraints	23
3.7	Scheduled System Alteration	24
3.8	Works or intervention due to a network failure or an emergency case	26
3.9	Network upgrade for efficiency purposes	27
3.10	Coordination between the Parties	28
3.11	Financial conditions	28
3.12	Relations with end-Users and branding	29
4	Property rights	30
5	General terms and conditions	31
5.1	Confidentiality	31
5.2	Force Majeure	31
5.3	Limitation of Liability	32
6	Procedure for reaching a LLU Agreement	33
7	Schedules 1 to 10	33
Schedule 1 - Service Description - Metallic Path Facility		34
1.1	Description	34
1.2	Types Of Offered Loops	34
1.3	Network Termination Points	35
1.4	Boundary Conditions And Prerequisites	35
1.5	Provisioning and Cessation	37
Schedule 2 - Service Description - Sub-Loop Unbundling (SLU)		38
2.1	Description	38
2.2	Types Of Sub-Loops Offered	38
2.3	Network Termination Points	39
2.4	Boundary Conditions And Prerequisites	39
2.5	Provision Of SLU	39
2.6	Backhaul Connections in the context of SLU	39
2.6.1	Generalities	39
2.6.2	BTC Services	40
2.6.3	Duct Sharing Service (DSS)	41
2.6.4	BFL Services	44
Schedule 3 - Service Description - Shared Local Loop Service (SLLS)		46
3.1	Description	46
3.2	Types Of Offered Loops	47
3.3	Network	47
3.4	Boundary Conditions And Prerequisites	49
3.5	Provisioning and Cessation	50

Schedule 4 - Service Description - Tie cables.....	51
4.1 Internal tie cables.....	51
4.2 External tie cables.....	52
4.3 Tie cables management.....	53
Schedule 5 - Technical specifications for Transmission Equipment In The Local Loop	54
5.1 Introduction	54
5.2 Cable Pair Management and Network Characteristics.....	54
5.3 Power Spectrum Management Of The Equipment To Be Connected To The Metallic Path Facility.....	59
5.4 Mixture of CO and RT deployments.....	62
Schedule 6 - Planning and Operation.....	64
6.1 Preliminary exchange of information	64
6.2 Electronic Information exchange.....	64
6.3 Forecasting	64
6.4 Fault Reporting And Repair.....	65
Schedule 7 - Ordering and Provisioning Procedure	76
7.1 Appointment handling	76
7.2 Provisioning of tie cable	76
7.3 Provisioning procedure of Metallic Path Facility.....	78
7.4 Provisioning Procedure of Shared Local Loop Services (SLLS)	92
7.5 Provisioning Procedure of Backhaul services in the context of SLU	99
Schedule 8 - Tariffs.....	102
8.1 Internal tie cable.....	102
8.2 External tie cable	102
8.3 Metallic Path Facility (MPF)	102
8.4 Shared Access.....	104
8.5 Backhaul services in the context of SLU	104
8.5.1 Backhaul Transmission Capacity (BTC Services).....	104
8.5.2 Duct Sharing Services (DSS).....	104
8.5.3 Backhaul Fibre Link (BFL Services).....	104
8.6 Fault Repair – Standard SLA	105
8.6.1 The fault repair is achieved within T40.....	105
8.6.2 The Operator wishes that the fault repair be done prior to another End-User's request or outside working hours. In this case, the following prices are applicable:	105
8.6.3 Manpower fees	105
8.7 Fault Repair – Business SLA	106
8.7.1 EPT's intervention is to be done within T41 for a LLU Service covered by a Business SLA (24/24h, 7/7d).....	106
8.7.2 Manpower fees	106
8.8 Manpower fees	106
Schedule 9 - Parameter Schedule.....	108
9.1 Provisioning of MPF	108
9.2 Provisioning of SLLS.....	108
9.3 Provisioning of tie cables	109
9.4 Fault Reporting and Repair.....	109
9.5 Other.....	109
Schedule 10 – Business SLA	110
10.1 Definitions related to the Business SLA	110
10.2 Terms and conditions of the Business SLA.....	110
10.3 Business SLA fault reporting and repair.....	111
10.4 Business SLA characteristics.....	112
10.5 Penalties	112

1 Introduction

1.1 Purpose

This Reference Unbundling Offer (“RUO”) defines the unbundling terms and conditions, which shall apply and be granted by EPT to Other Alternative Operators (“Operator”) for the provisioning of EPT’s (“Entreprise des P&T Luxembourg”) Local Loop Unbundling services (“LLU Services”), as required by Regulation 08/132/ILR of July 18, 2008 and its subsequent amendments.

All Schedules attached to this RUO form an integral part hereof and detail the different LLU Services and their respective applicable provisioning terms offered by EPT under this RUO.

The Co-Location services as from time to time referred to in this RUO are part of and subject to the applicable Reference Co-Location Offer (“RCO”) and shall be provided by EPT to the Operators in compliance with the specific terms and conditions of the said RCO.

This RUO does not purport to diminish the rights of Operators to seek additional services, or EPT’s obligation to provide additional services under applicable law.

Apart from this RUO, EPT’s commercial offers are still available at the simple demand of the Operator.

1.2 Services covered

The LLU Services covered by this RUO are:

- Unbundled metallic path facility service,
- Shared access service,
- At the Operator’s choice, backhaul transmission capacity service (“BTC Services”) or duct sharing service (“DSS”) in strict relation to SLU, subject to the specific prerequisites and conditions set forth in this RUO. Apart from this RUO and other Reference Offers, all EPT’s, commercial offers are still available at the simple demand of the Operator.
- Backhaul fibre link (“BFL”) in case EPT cannot provide BTC or DSS and

provided BFL is technically feasible. Apart from this RUO, EPT's commercial offers are still available at the simple demand of the Operator.

1.3 Minimal terms

This RUO defines the minimal unbundling terms and conditions which EPT will grant to other Operators. Nevertheless, EPT reserves the right to provide more beneficial terms and conditions, in accordance with the applicable regulatory framework, including the principle of non-discrimination.

1.4 No content liability

No Operator (including EPT) shall be responsible for the content of calls or transactions passed through its own or an unbundled Operator's network. Laws and regulations regarding confidentiality and access by legal authorities to calls on the Operator's and EPT's network will apply.

1.5 Term

This RUO is valid as from date of approval by ILR unless:

- A new RUO is approved or adopted by the ILR, as defined in Clause 2 below, or
- A material change occurs in the laws or regulations, governing telecommunications in Luxembourg.

1.6 Amendments

The content of this RUO may be timely reviewed and amended in order to comply with applicable rules and regulations.

Furthermore, ILR has the right to request or impose on EPT modifications to the applicable RUO or the adoption of a new RUO to be undertaken by EPT in compliance with the applicable procedural rules and regulations.

1.7 Interpretation rules

Unless expressly defined otherwise hereafter (in particular in article 2 – Definitions below), the terms used in this RUO shall be construed and interpreted in accordance with the provisions of the Regulations of the European Parliament

and the European Council on Unbundled Access to the Local Loop EU Regulation (EC) No. 2887/2000.

1.8 Prices

All prices mentioned in this RUO, including those specified in the Appendices attached hereto, are in EURO (€) and exclusive of Value-Added Tax (VAT) or any other legal taxes, which will be added where applicable.

2 Definitions

(in the event of doubt, the description in the relevant text prevails to the definition given here)

Defined Terms	Meaning
Active Local Loop	Continuous copper pair in the local loop between the Network Termination Point (NTP) and the Main Distribution Frame (MDF) providing service to the End-User.
Active Sub Loop	Continuous copper pair in the local loop between the Network Termination Point (NTP) and a concentration point or a specified intermediate access point providing service to the End-User.
ADSL	Asymmetrical Bit-Rate Digital Subscriber Line, being ADSL 1, ADSL 2 or ADSL 2+.
BTC	Backhaul Transmission Capacity.
BTC Service(s)	The services for BTC that EPT offers to provide to the Operator in relation to SLU under the terms and conditions of this RUO.
BFL	Backhaul Fibre Link.
BFL Service(s)	The BFL services that EPT offers to provide to the Operator, subject to the terms and conditions of this RUO, in strict relation to SLU and limited to a situation where BTC or DSS is not available.
Business Hours	From Monday to Friday, 08:00-12:00 and 13:00-17:00 CET, except on public, legal or usage holidays in Luxembourg.
Cancellation Request for Low Bandwidth Service	A request from an End-User to EPT in order to cancel Low Bandwidth Service provided by EPT.
Calendar	Time sheet defining for each Operator the maximum number of appointments per day agreed with EPT for MPF activation/migration, it being specified that this Calendar shall be used by the Operator to exchange the End-User's appointments with EPT.
CO	Central Office location.
Co-Location	The provision by EPT of physical space and technical facilities necessary to reasonably accommodate and connect the relevant equipment of an Operator.
Co-Location Equipment Room	Physical space in EPT site allocated for Co-Location purposes.
Co-Location Space	Specific physical space(s) reserved by EPT in a given Co-Location Equipment Room for a given Operator according to the needs expressly specified by the latter.
Commencement Date	Forecasting term for a date when e.g. a Service will start.
Confidential Information	Information that shall not be shared, in whole or in part, with third parties other than EPT and the relevant Operator, including in particular financial information, technical data, discoveries, know-how, techniques, designs, sketches, photographs, plans, drawings, blueprints, diagrams, specifications, marketing plans, studies, results, goals, sales figures, or other business information as well as any combination thereof.
CPM	Cable Pair Management Plan.

Disclosing Party	The party in a LLU Agreement handing over Confidential Information.
Distribution Cable	The copper cable located behind the street cabinet in the direction of the relevant End-User's Premises.
DS	Duct Sharing.
DSS	The DS services that EPT offers to provide, subject to the terms and conditions of this RUO, to the Operator in strict relation to SLU.
End-User	Any natural or legal person with whom EPT or Operator(s) has entered into an agreement for the provision of publicly available telecommunication services.
EPT	Entreprise des Postes et des Télécommunications, an autonomous " <i>Etablissement public</i> " created by the " <i>Loi du 10 août 1992 portant création de l'Entreprise des Postes et Télécommunications</i> ".
EPT Access Point	The physical interface within EPT's network at which the interconnection services as referred to and defined in the RIO can be obtained.
EPT FCP	The Fault Contact Point provided by EPT to the relevant End-User and the Operator for addressing Fault Reports.
EPT Infrastructure	The civil infrastructure of EPT's network used in relation to of for the purpose of electronic communications, including ducts, splicing chambers, manholes, street cabinets, Co-Location Equipment Rooms, etc.
EPT's Website	EPT's interconnect Web site at: http://www.pt.lu
ETS	European Telecommunication Standards.
FCP	Fault Contact Point.
Fault Report	As the case may be, either written report sent by Operator to EPT in case of faults discovered within the Local Loop Unbundling (LLU) service or fault notification made per telephone to EPT by the End-User in case of faults discovered within the Low Bandwidth Service in the context of Shared Local Loop Service (SLLS).
Feeder Cable	The copper cable between the Main Distribution Frame (MDF) at the EPT Local Exchange and the street cabinets.
Forecast	The process of Operator's forecasting future demands of LLU services or SLLS.
FTTC/FTTB	Fibre to the Curb / Fibre to the Building.
HDF - Handover Distribution Frame	The HDF will be located in the Operator specified Co-Location area. The HDF includes only the "iron work" and will be provided by the Operator, while the termination blocks of the tie cables to be fixed on the HDF will be provided by EPT together with the ordered tie cables.
HDSL	High Bit-Rate Digital Subscriber Line.
High Bandwidth Problem	An existing or presumed fault declared by the End-User as fault via a Fault Report concerning the functionality of the High Bandwidth Service of SLLS.
High Bandwidth Services	xDSL services offered by an Operator to the End-User (s) via SLLS.
ILR - Institut Luxembourgeois de Régulation	The national regulatory authority in Luxembourg.
Incident Ticket	The written confirmation notice to be sent by EPT to Operator FCP (i) upon

	opening of an incident ticket after receipt of a valid Fault Report communicated by the Operator to relevant EPT FCP and specifying EPT's reference number of the concerned incident ticket ("Incident Ticket Opening") and afterwards (ii) upon closing of the relating incident ticket, either after remedy of the concerned fault or after closure of the Fault Report for any other valid reason ("Incident Ticket Closing").
ISDN	Integrated Services Digital Network.
LLU	Local Loop Unbundling.
LLU Agreement	The agreement between EPT and the concerned Operator, including the schedules and – if relevant – amendments thereto, covering LLU Services and which: (i) has already been executed prior to the entry into force of this RUO and will shall be automatically amended thereby, or which (ii) will be later on executed for the purpose of and in compliance with this RUO, which shall be an integral part thereof.
LLU Services	Unbundling services, including as the case may be (i) metallic path facility, (ii) sub-loop unbundling services, (iii) shared local loop services, as well as provided no copper cable is available in the context of SLU (iv) BTC Services or DSS, at the Operator's choice, in context of SLU provided no copper cable is available.
Local Exchange	The telephony exchange closest to a given End-User.
Local Loop	The physical twisted metallic pair circuit connecting the network termination point at the relevant End-User's premises to the main distribution frame or equivalent facility in the fixed public telephone network.
Local Sub-Loop	A partial local loop connecting the network termination point at the relevant End-User's premises to a concentration point or a specified intermediate access point in the fixed public telephone network.
Low Bandwidth Problem	An existing or presumed fault declared by the End-User as being a fault via a Fault Report concerning the functionality of the Low Bandwidth Service of SLLS.
Low Bandwidth Services	PSTN or ISDN services offered by EPT to the End-User via SLLS.
MDF - Main Distribution Frame	The termination point of the raw copper circuit in EPT's Local Exchange building.
MPF - Metallic Path Facility	A twisted pair of fully metallic continuous unequipped copper wires on the section between EPT's MDF at the EPT Local Exchange and the relevant End-User's address connected on a Network Termination Point if it exists or if it is possible to provide .
MDU	Multi Dwelling Unit (Apartment blocks)
MPFNP	MPF combined with Number Porting
MSN	Multiple Subscriber Numbers.
Non-Active Local Loop	A Local Loop that is not actively used by EPT to provide a telecommunication service to a specific End-User before the unbundling of the Local Loop is requested.
Non-Active Local Sub Loop	A Local Sub Loop that is not actively used by EPT to provide a telecommunication service to a specific End-User before the unbundling of the Local Sub Loop is requested.
NTP - Network Termination Point	The termination point of the raw copper section at the relevant End-User's premises at which point the EPT's access network ends.

Operator	Any legal or natural person exploiting telecommunications networks and/or providing telecommunications services in Luxembourg.
Operator Access Point	The physical interface within the Other Alternative Operator's System at which the Interconnection Services can be obtained.
Operator FCP	The Fault Contact Point provided by the Operator for the relevant End-User and EPT.
Order Forecast	Written plan to be submitted by the relevant Operator to EPT and stating Operator's future orders for LLU Services or SLLS provided by EPT.
Party	As the case may be, either EPT or the Operator with which a LLU Agreement for the provisioning of raw copper or SLLS in the local loops of EPT is (being) concluded.
Parties	EPT and the Operator with which a LLU Agreement for the provisioning of raw copper or SLLS in the local loops of EPT is (being) concluded.
POTS	Plain Old Telephone System.
PRI	Primary Rate Interface.
PSD	Power Spectral Density.
PSM	Power Spectrum Management.
PSTN	Public Services Telephone Network.
RCO - Reference Co-Location Offer	The applicable EPT's reference offer for Co-Location services in force.
Ready for Service Date	Date at which a given LLU Service should be ready for commercial launch.
RDSLO - Reference DSL Offer	The applicable EPT's reference offer for DSL services in force.
Receiving Party	The Party in an agreement receiving Confidential Information.
RFS	Ready for Service.
RLO - Reference Line rental Offer	The applicable EPT's reference offer for line rental services in force.
RT	Remote Terminal location
RUO - Reference Unbundling Offer	The present reference offer for LLU Services.
Schedule(s)	The schedule(s) attached to this RUO, as listed in its table of contents
SDSL	Symmetric Single pair High Bit Rate Digital Subscriber Line.
SLA- Service Level Agreement	The standard SLA offered by EPT for the LLU Services under this RUO or, upon the Operation's express option for professional End-Users only, the Business SLA.
Shelter	Building or container housing telecom equipment
Short Term Forecast	Forecast covering next coming 1 – 6 months as of the date of its issuance.
Site	Physical building housing telecom equipment.
SLCP(s) - Sub Loop Connection Point(s)	The relevant Sub Loop Connection Point(s) referred to under this RUO are defined in a separate document published on EPT's Website.
SLLS	Shared Local Loop Service offered by EPT as defined in this RUO.

SLU	Sub Loop Unbundling.
SPOC	The Single Point Of Contact provided by either Party to the other for the purpose and within the frame of the LLU Agreement and related LLU Services.
Street Cabinet	The distributor allowing cross-connection between the feeder cable pairs and the distribution cable pairs.
Sub loop MPF like	A twisted pair of fully metallic continuous unequipped copper wires on the section between an EPT's concentration point or a specified intermediate access point and the relevant End-User's address connected on a Network Termination Point if it exists or if it is possible to provide .
xDSL	ADSL1, ADSL2, ADSL2+, VDSL2 and other xDSL when applicable

3 The RUO Principles

3.1 Service Description

3.1.1 The LLU Services shall:

- (i) be provided by EPT to an Operator in accordance with the terms and conditions of this RUO;
- (ii) consist of the following services:
 - Provisioning by EPT to an Operator of a MPF (or a Sub Loop MPF like) to enable the Operator to provide telecommunications service(s) to End-Users, or
 - Transfer of an existing metallic pair from EPT to the Operator, provided this is part of an active loop or an active sub loop;
 - Provisioning of shared access services, or
 - Provisioning of BTC Services or DSS, at the Operator's choice, or
 - Provided no BTC Services or DSS are available, provisioning of BFL Services if technically feasible.(if not technically feasible, the proof has to be fully provided by EPT to the requesting operator and to ILR, within a time frame of maximum five working days from the day of request by the operator) ;
- (iii) only be used for the delivery by the relevant Operator to End-Users of LLU Services, which are compliant with the specifications as referred to in the relevant Schedules; and
- (iv) only be provided in conjunction with the EPT's Co-Location Service for MPF-access as defined in the applicable RCO.

3.1.2 The EPT LLU Services shall only be provided on a line where:

- (i) A NTP exists and is in service in the relevant End-User's premises, or where a NTP doesn't exist but is technically possible and has been asked for. (in this case, the "demande de raccordement souterrain" may be transmitted to the EPT by the Operator, on behalf of the mutual client, following the terms of schedule 12.)

- (ii) The Operator has ordered the required HDF and tie cables, and
- (iii) As regards to the transfer of an existing metallic pair from EPT to the Operator, the concerned End-User has prior requested that the contract(s) for the existing End-User service(s) in force at that time between the said End-User and EPT to be terminated, all this in accordance with EPT's respective applicable terms and conditions. For this purpose, the concerned End-User may empower in writing the concerned Operator for cancelling on the End-User's behalf all existing telecommunication services provided by EPT to the End-User and carried by the existing metallic pair to be transferred. It being specified that in such case the Operator will be responsible for evidencing upon first request its valid empowerment, if required at that time or later on by EPT.

3.2 Responsibilities

3.2.1 EPT's responsibilities

EPT shall be responsible for:

- (i) The access network used to provide the LLU Services.
- (ii) Providing BTC or DS, at the Operator's choice..
- (iii) Providing BFL provided BFL is technically feasible and where EPT cannot provide BTC or DS.
- (iv) Connecting or disconnecting tie cables and individual access lines in response to Operator confirmed orders submitted to EPT in accordance with Schedule 6 - Planning and Operation.
- (v) Providing billing information, as specified hereafter in article 3.11 - Financial conditions.
- (vi) Conducting tests, if need be, in the context of cable and spectrum management as defined in Schedule 5 - Technical specifications for Transmission Equipment In The Local Loop to protect the integrity of the access network.
- (vii) Informing Operator on system alteration to be made in the network and having a potential effect on the services offered by the Operator,

all these subject to the terms and conditions of as well as to the extend of this RUO.

EPT shall not be responsible for:

- (i) Expanding, modifying or conditioning in any way EPT's access network (or part of it,) to provide EPT LLU Services, and EPT shall in no case be obliged thereto, unless where a NTP doesn't exist but is technically possible and has been asked for (in this case, the "demande de raccordement souterrain" may be transmitted to the EPT by the Operator, on behalf of the mutual client, following the terms of schedule 12.). and only to the strict extend as specifically needed.
- (ii) The performance and follow-up of any service that the Operator operates on a line and provided as part of the LLU Services, as long as EPT does not alter its network in such a way that could have a negative impact on the quality of service on a line and as guaranteed as part of the LLU Services.

3.2.2 Operator Responsibilities

The Operator shall be responsible for:

- (i) Ordering or terminating, as the case may be, a line in accordance with Schedule 7 - Ordering and Provisioning Procedure.
- (ii) Using exclusively telecommunications terminal equipment compliant to "*Règlement grand-ducal du 4 février 2000 concernant les équipements hertziens et les équipements terminaux de télécommunications et la reconnaissance mutuelle de leur conformité*"
- (iii) Ensuring that all its staff and subcontractors intervening in relation to LLU Services or this RUO had the relevant experience and be appropriately skilled and trained to properly and timely comply with the terms and conditions of this RUO.
- (iv) Conducting appropriate fault testing and producing associated Fault Reports to evidence faults in the EPT's network in accordance with Schedule 6 - Planning and Operation.
- (v) Informing the relevant End-User about all technical modifications required on his/her existing installation and the service impacts that might occur.

- (vi) Properly informing EPT for the purpose of and in relation to the LLU Services and this RUO.
- (vii) Tracking EPT's system alteration activities in order to make sure that the End-User's services are maintained. In order to allow the Operator to do so, EPT will provide, in actual real time changes (journally), information regarding such alteration activities to the Operator in the file "concentration points" published on EPT's Website. Furthermore, new projects are announced by EPT in due time by mail.
- (viii) Cooperate with EPT's reasonable requests for and/or in relation to the provisioning of the LLU Services.

3.3 EPT's General Power

3.3.1 Occasionally, EPT, acting reasonably, may suspend services as described in this RUO for any of the following reasons:

- (i) If required by a duly authorised national or international authority duly authorised and empowered to do so, or
- (ii) For the purpose of repair, maintenance and/or improvement of any of EPT's telecommunication systems and telecommunications apparatus.

3.3.2 Wherever possible, EPT will give the Operator reasonable written notice before performing any of the actions related to the above and EPT will do its best efforts to restore MPF as soon as possible after the concerned temporary suspension. EPT shall give on the Operator's reasonable request a detailed written technical report after any incident having had an impact on the Operator's services. This shall enable the Operator to clearly understand the source of the issue. In case the information provided by EPT is insufficient, the Operator may request further information. EPT shall reply within maximum five (5) working days after the day of such request.

3.3.3 EPT shall have the right to disconnect the compliant equipment or any part of it without prior reference or notice to the Operator if at such time, in EPT's reasonable opinion it is exposing or could expose any person to any danger of death or injury. EPT shall give a detailed written technical report after any such incident. This shall enable the Operator to clearly understand the source of the issue. In case the information provided by EPT is insufficient, the Operator may

- request further information. EPT shall reply within maximum five (5) working days after the day of such request.
- 3.3.4 Without prejudice to the foregoing clause, EPT shall have the right to request the Operator to disconnect any compliant equipment or any part of it within a reasonable time period, if, at such time, in EPT's reasonable opinion, it is causing, suspected of causing or could cause damage to the MDF Site or EPT's telecommunications apparatus or any other property or if such exposure or damage is or may be imminent. EPT will immediately notify the Operator of the circumstances in which such compliant equipment has to be disconnected. If the Operator has not disconnected the concerned equipment within a reasonable time period, EPT shall have the right to disconnect itself the concerned equipment after prior notification thereof to the Operator.
- 3.3.5 EPT shall not be liable to the Operator for any loss, damage or injury arising due to EPT's action in disconnecting the compliant equipment or for any interruption to the telecommunication service carried out by the Operator using the compliant equipment howsoever caused, except where the loss damage or injury is caused directly due to EPT's gross negligence.
- 3.3.6 In the event of a disconnection in accordance with the above, the Operator shall not reconnect the compliant equipment until the reasons for its disconnection have been fully remedied. In case the danger or threat referred to above is caused directly due to EPT's negligence, then EPT shall reimburse to the Operator the evidenced reasonable direct costs of reconnecting the compliant equipment.

3.4 Quality of Service – Service Level Agreement (SLA)

3.4.1 Generalities

EPT will provide the LLU Services in case of a transfer of an existing metallic pair together with the telecommunication services delivered to the End-User by EPT at the time of such request, or in case of a new MPF provided that a spare copper pair is available (or where a NTP doesn't exist but is technically possible and has been asked for. (in this case, the "demande de raccordement souterrain" may be transmitted to the EPT by the Operator, on behalf of the mutual client, following the terms of schedule 12.)) between the End-User's building and the Operator's SLCP or, as the case may be, MDF, in accordance with this RUO.

Within the frame of this RUO, EPT offers two different service levels for the LLU Services, i.e.:

- (i) a Standard service level ("**Standard SLA**"), which applies for any LLU Services to be provided under this RUO without additional fee to be paid for by the Operator, and
- (ii) a Business service level ("**Business SLA**"), which may be specifically opted in by the Operator per LLU Service for the benefit of professional End-Users exclusively, while any such option shall lead to the application of the corresponding Business SLA fees as set forth in Appendix 8 - Tariffs attached hereto.
- (iii) If an OAO wants a higher level of service for a particular Local Loop Unbundling Service (Premium Service Level Agreement), EPT has to provide upon written request of the concerned OAO a draft offer for the specific Service Level Agreement so required by the OAO, which shall be in line with EPT's network technical specifications and capabilities. This offer shall be submitted, with details about the EPT's network technical specifications and capabilities, to the OAO and to the ILR, which shall accept or amend the proposition of EPT, after consultation of both EPT and the requesting OAO.

For the avoidance of doubt, in case the Operator opts for the Business SLA while the LLU Agreement it entered into with EPT has been concluded prior to the

entry into force of this RUO, the Operator agrees to priory enter into the amendment to the LLU Agreement covering the specific matter of Business SLA. The Operator may choose the applicable type of SLA for any given LLU Service:

- (i) with the relevant order, while in such case the specified SLA shall be applicable as from the activation date of the said LLU Services, or
- (ii) at a later date, while in such case the newly specified SLA shall be applicable as from the first day of the calendar month following the one during which the SLA change has been validly required by the Operator.

3.4.2. Standard SLA and Premium SLA

The Service levels set out in the relevant Schedules attached hereto, match in all cases the service levels granted by EPT to its retail End-Users for similar services, except otherwise agreed between parties.

It is specified, among other things, that:

(1) The provisioning time of LLU Services by EPT is within maximum the number of business days as detailed in the applicable document "conditions générales applicables aux services de télécommunication" for EPT retail customers, where it concerns "un simple raccordement avec point de terminaison existant" following the survey request, except where the required provisioning works are of such importance that they need substantial works to be carried out (e.g. civil works). In the latter case, EPT has to inform the Operator about the substantial works to be carried out for the first time within two (2) business days and will agree with the Operator upon the provisioning time.

For the sake of clarity and avoiding misunderstandings, the "provisioning time" includes the time period needed for the survey and the time period for the delivery of service after a firm order . This means that the "provisioning time" begins at the moment when the Operator submits a survey request and ends when the LLU (or SLU) service is delivered (= provided) and the order is closed after confirmation by EPT to the Operator, provided that EPT has issued a positive reply to the survey and that the Operator has done an effective order. Therefore, the period of time existing between the positive reply of EPT and the effective order of provisioning by the Operator, is not included in the term

"provisioning time". If the Operator has not taken the first available appointment date in the booking manager system, the period between the first available appointment and the effective appointment taken by the Operator will not be considered as "provisioning time".

In case no works have to be carried out in the field (outside of the MDF) by EPT staff, the provisioning time as listed here above is strictly guaranteed.

In case works have to be carried out in the field (outside of the MDF) by EPT staff, the provisioning time shall be handled through the appointment handling procedure as referred to in this RUO, but the provisioning time as listed here above is also to be followed, and EPT has to foresee the possibilities of appointments through the appointment handling procedure in accordance to this provisioning time.

For the above mentioned periods:

(a) the specified time period shall automatically stop in case the concerned provisioning requires an appointment with the End-User, while for reasons beyond EPT's control (e.g. End-User's absence or unavailability) such appointment could not be fixed in due time with the End-User.

If EPT's staff, for reasons beyond EPT's control (e.g. End-User's absence or unavailability), could not intervene in due time despite the appointment fixed with the End-User, the "stop" of the specified time has to be duly reported, in detail, by EPT to the Operator, and is only effective after this reporting. In case of serious doubt, the Operator may request of proof of the effective need of the "stop", and EPT has to respond to that request in a delay of one (1) working day.

(b) the specified time period shall only restart as of the time at which the event(s) specified in point (a) have been duly remedied and EPT's staff could duly and timely intervene to perform provisioning of the LLU Service. The "restart" of the specified time begins with a new appointment fixed in the online booking manager by EPT to the Operator, and is only effective after this reporting. In case of doubt, the Operator may request why the "restart" has not yet been given, and EPT has to respond to that request in a delay of one (1) working day.

(2) EPT will re-establish LLU Services within one (1) business day maximum following

the day at which a Fault Report has been validly submitted, except where the required clearance works are of such importance that they need substantial works to be carried out (e.g. civil works). In this case, EPT has to inform the Operator about the situation for the first time within a time frame of one (1) business day maximum following the day at which a Fault Report has been validly submitted, and every two (2) business days thereafter and on request by the Operator EPT will provide an indication regarding the nature of the fault and the expected repair time. If during the repair works it occurs that the initially expected time for restoration can not reasonably be maintained, EPT shall inform the Operator immediately hereof and specify the reasons thereof.

For the above mentioned periods:

(a) the specified time period shall stop in case the concerned fault clearance requires an appointment with the End-User, while for reasons beyond EPT's control (e.g. End-User's absence or unavailability) such appointment could not be fixed in due time with the End-User or if EPT's staff could not intervene in due time despite the appointment fixed with the End-User. The "stop" of the specified time has to be duly reported by EPT to the Operator, and is only effective after this reporting. In case of serious doubt, the Operator may request of proof of the effective need of the "stop", and EPT has to respond to that request in a delay of one (1) working day.

(b) the specified time period shall only restart as of the time at which the event(s) specified in point (a) above have been duly remedied and EPT's staff could duly and timely intervene to clear the concerned fault. The "restart" of the specified time begins with a new appointment fixed in the online booking manager by EPT to the Operator, and is only effective after this reporting. In case of doubt, the Operator may request why the "restart" has not yet been given, and EPT has to respond to that request in a delay of one (1) working day Operator.

(3) If EPT fails to provision or to re-establish one or several LLU Services within the above mentioned time period while either the installation time, or the concerned fault clearance and/or the restoration delay are within EPT's sole responsibility, the Operator will be granted upon written request with a financial indemnity equivalent to a one month fixed fee of the concerned LLU Service(s). Should either the installation time, or the concerned fault clearance and/or the restoration delay fall beyond fifteen (15) calendar

days after the installation or restoration time fixed in this SLA, the said indemnity will be increased to be equivalent to three-month fixed fee of the concerned LLU Service(s).

The above indemnity shall not apply in case:

(a) of a Force Majeure event (where the reasonable proof of these event has to be given by EPT); or

(b) the Operator claims for the above-mentioned financial indemnity later than one hundred eighty (180) calendar days as from the day after which the warranted provisioning or restoration time elapsed; or

(c) (in the case of provisioning failing only) of the requests which are significantly (by 10 %,) in excess of the number of monthly by EPT realized requests of the Operator calculated from an average of the three previous months; or

(d) EPT has been prevented in whole or in part to intervene in due time to comply with the warranted provisioning or restoration time, notably due to the Operator's and/or the concerned End-Users act or omission (where the reasonable proof of such prevention has to be given by EPT).

(4) Fault clearance outside Business Hours or with priority handling is possible for exceptional cases, provided the Operator has prior accepted, for each relevant exceptional case, the respective fees set out in points 6.4 of Schedule 6 and 8.5 of Schedule 8 attached to this RUO. In such case, the terms and conditions of the Standard SLA shall not apply, while, according to the event concerned, the Parties will agree upon a reasonable time schedule applicable to such provisioning or fault clearance. The procedure to provide, and publish in the RUO, the contact EPT's 24/24 7/7 Fault Contact Point is: (Phone number) and: (Fax number described chapter 6.4.1number).

(5) If an Operator wants a higher level of service for any particular Local Loop Unbundling Service/LLU Services (Premium Service Level Agreement), EPT has to provide upon written request of the concerned Operator a draft offer for the specific Service Level Agreement so required by the Operator, which shall be in line with EPT's

network technical specifications and capabilities. This offer shall be submitted, with details about the EPT's network technical specifications and capabilities, to the Operator and to the ILR, which shall accept or amend the proposition of EPT, after consultation of both EPT and the requesting Operator it may opt for a Business SLA as described in Schedule 10 of this RUO.

3.4.2 Business SLA

If an Operator wants a higher level of service for a particular LLU Service, it may expressly opt for a Business SLA as specified in article 3.4.1 above.

Nevertheless, the opting for a Business SLA under this RUO is subject to the signature by both Parties of a specific Business SLA Agreement as referred to in Schedule 10 – Business SLA. Such a Business SLA Agreement shall be provided for a minimum one(1)-year period. After expiry of this 1st Year, the Operator may terminate the concerned Business SLA Agreement upon a (1)-month prior written notice.

In any and all cases where the Operator validly opts for a Business SLA, the terms and conditions set forth in Schedule 10 – Business SLA shall apply, it being specified for the avoidance of doubt that those terms and conditions shall only apply provided that the Operator has expressly specified in the concerned Fault Report sent to EPT FCP that the LLU Service(s) affected by the so reported fault is (are) duly covered by a Business SLA.

The contact points and procedures applicable for LLU Services covered by the Business SLA are specified in the Business SLA Agreement.

3.4.3 Specific case of Rush Order(s)

Urgent (Rush) orders (Rush orders e.g survey, installation, modification, fault repair) are described in schedule 11 respectively for fault repair in schedule 8 (chapter 8.6.2) of this RUO, and are accessible for every Operator under the present RUO, without restrictions.

In case an Operator is willing that the LLU Agreement covers specific cases of urgent orders which are not covered by schedule 11, whatever the type thereof, to be carried out with priority and within short periods upon Operator's express demand ("Rush Orders"), EPT will provide the said Operator upon written request

with a commercial offer specifying the terms and conditions of acceptance and treatment by EPT of such specific cases of Rush Orders, including in particular:

- (i) the list of services and/or products within LLU Services concerned by the possibility of such specific cases of Rush Orders,
- (ii) the hours of reception and treatment of such specific cases of Rush Orders (normal business hours or otherwise),
- (iii) the lump price supplement to be paid specifically in such case, depending notably on the concerned maximum treatment time period and the hours (normal business hours or otherwise) during which a Rush Order can be treated by EPT, as well as
- (iv) the procedure to be complied with by the Operator in case of such specific cases of Rush Orders.

Upon agreement of this specific commercial offer by the Parties, the corresponding provisions will be included in the respective LLU Agreement to be signed by and between the Parties.

3.5 System protection

Each Party is responsible for the safe operation of its respective system and shall take all reasonable and necessary steps and measures in its operation, implementation and maintenance to ensure that its system does not:

- (i) Endanger the safety or health of employees, contractors, agents or End-Users of the other Party.
- (ii) Damage, interfere with or cause any deterioration in the operation of the other Party's system or a third party operator's system.

3.6 Configuration and technical constraints

3.6.1 Access lines will be provided in accordance with the technical constraints specified in Schedule 5 - Technical specifications for Transmission Equipment In The Local Loop. EPT shall not be liable for a shortage of access lines or cable saturation, e.g. due to broadband usage. EPT shall remedy shortage issues for Operators in the same way it does for its own customers. If an Operator has

- reasons to believe that it has not been treated in the same way as EPT's End-Users or other Operators, the Operator can require EPT to give further explanations in this respect. EPT shall reply in writing to the Operator with a copy to the ILR, within maximum five (5) working days after the day of request by the Operator.
- 3.6.2 However, in case of cable saturation, meaning that no additional broadband connection is possible in that cable, EPT will make all reasonable efforts to implement an appropriate technical solution, provided such solution is economically balanced. If an Operator has reasons to believe that it has not been treated in the same way as EPT's End-Users or other Operators, the Operator can require EPT to give further explanations in this respect. EPT shall reply in writing to the Operator with a copy to the ILR, within maximum five (5) working days after the day of request by the Operator.
- 3.6.3 Such technical solutions could consist in the implementation of remote equipment in the field, closer to the End-Users. In this case, the copper pairs may disappear between the CO and this RT and the unbundling will then have to be changed to SLU. This in the common interest in increasing the available bandwidth offers to the customer based on shorter loops. In such case, the provisions of article 3.7.1 below shall apply.
- 3.6.4 EPT can reserve a minimal number of pairs in each cable section:
- (i) For repair of existing services, or
 - (ii) In case of shortage after prior consultation with ILR.

3.7 Scheduled System Alteration

3.7.1 Scheduled system alteration with major impact

When EPT wants to make a system alteration which may reasonably have a major impact on the proper provision of the LLU Services under this RUO to one or several Operator(s), EPT shall notify the Operator and ILR as soon as the alteration is planned internally but in no case shall the notification be less than 3 months before the start of the said alterations., which shall specify the technical details of the contemplated system alteration and the foreseen date of the said

anticipated system alteration. With such a notification, EPT shall always provide to the Operator the complete information including, to the extent reasonably practicable, the potential impact thereof on the service(s) provided by the Operator to the End-Users. This notification shall include a full impact analysis. The 3 months notice is considered as a minimum delay. If the Operator provides objective and written arguments that the proposed changes involve major technical alterations on the Operator's side, the Operator can request EPT within five (5) working days after the day of EPT's notification to adapt the notice period in a way to reasonably allow the Operator to integrate the changes without severely affecting its service or quality. EPT will agree with the proposed period, unless it has objective, valid, written and reasonable arguments to decline the Operator's request. In the latter case, EPT will propose an alternative date to implement the Scheduled System Alteration. In case EPT and the Operator cannot agree on a common timing, the ILR will be asked to mediate on this issue in accordance with article 78(6) of the *Loi du 30 mai 2005 sur les réseaux et les services de communications électroniques*.

EPT may be forced to abandon existing copper cables in whole or in part in the following specific cases:

- Obsolete copper cables (on a valid reason to be given on request to the ILR),
- Copper cables with unreasonably high maintenance costs (on a valid reason to be given on request to the ILR),
- Replacement of EPT's aerial network by another technology, in particular by underground network, (if the replacement is done by an underground copper cable LLU Services will be maintained),
- Reconstruction and/or reconfiguration of a road (e.g. construction of roundabouts, modification of a road layout or route...) impacting or affecting EPT's Infrastructure, (if the replacement is done by an underground copper cable the LLU Services will be maintained unless another choice is expressed by the concerned Operator(s))
- Filling factor of a copper cable's capacity below 5%, while the related costs for maintenance and service is above an economically reasonable threshold (on a valid reason to be given at request to the ILR).

In any of these specific cases, EPT has the right (on a valid reason to be given on request to the ILR) to review its network architecture by ceasing the existing copper cable and to replace it in whole or in part by fibre cables, after having duly informed the ILR. LLU Services already existing and provided on such cables will

then be ceased after the prior notice to the concerned Operator(s) as specified above.

For the sake of clarity, in such cases, the Operator has the right to migrate at its discretion, and without any costs related the migration works, its existing LLU Services to:

- SLU, provided this is technically feasible having regards to the specific circumstances,
- RDSLO,
- RLO, or
- Any EPT's wholesale (including commercial) products, as appropriate.

3.7.2 Scheduled system alteration without major impact

When EPT wants to make a system alteration which may reasonably not have a major impact on the proper provision of the LLU Services under this RUO to one or several Operator(s), it shall give to the concerned Operator(s) a prior notice having regards to the circumstances which shall in no case be less than seven (7) business days prior to the foreseen date of the said anticipated system alteration. Such notification shall specify the technical details of the contemplated system alteration, the foreseen date of the related works and the reasonably foreseeable impact of the said works on the LLU Services provisioning. The concerned Operator(s), after having received the said prior notice, has the right to invoke, if duly justified, the existence of a major impact. In this case, the point 3.7.1. (Scheduled system alteration with major impact) will be applied by the EPT.

3.8 Works or intervention due to a network failure or an emergency case

In case EPT has to intervene on its network further to a network failure or an emergency case, EPT will do its best efforts to limit the time of its intervention having a possible impact on the provisioning of the LLU Services to the reasonable minimum time having regards to the circumstances. In any case, EPT will inform the Operators of such an intervention as soon as reasonably possible, while the restoration of the service provisioning on the network shall be the priority.

The Operator will be treated in the same way as EPT End Users and other Operators.

3.9 Network upgrade for efficiency purposes

Except when given local circumstances require otherwise, in case EPT has to upgrade or modify its network for efficiency purposes (on a valid reason to be given on request to the ILR), while such an upgrade or modification will lead to the disconnection of any LEX, EPT shall give a (i) prior written notice thereof at least twenty-four (24) months before the said disconnection to the concerned Operator(s) as well a (ii) cease order six (6) months in advance of the disconnection date to allow each concerned Operator to arrange for a suitable alternative, in particular to ensure during that period the proper transfer of its respective equipment to one or several other Co-Location Equipment Room(s) or to an another place of its choice, as it deems appropriate.

EPT shall negotiate with the concerned Operator(s) in good faith an alternative solution before a firm decision on closing the concerned LEX is taken. This has to be done before the prior formal written notice thereof. The result of the negotiation shall be transmitted to the ILR. EPT shall ensure the concerned Operator(s) to be able to deliver a similar service.

After expiry of the above-mentioned twelve-month period, no Operator shall further use the impacted Co-Location Equipment Room(s).

For the sake of clarity, in such cases of disconnection of any LEX, the Operator has the right to migrate at its discretion its existing LLU Services to:

- Where technically feasible, a“Turnkey Plan solution” consisting in a shelter to be installed close to the LEX to be disconnected, whereas the shelter shall be reasonably dimensioned to host current and future unbundled lines, (the cost to install these shelter will be borne by EPT)
- SLU, provided this is technically feasible having regards to the specific circumstances,
- RDSLO,
- RLO, or
- Any EPT’s wholesale (including commercial) products, as appropriate, which may be different from a CU solution.

In any of the cases mentioned above, the costs for the related migration works will not be charged by EPT to the Operator.

In no case, such a change may result in any kind of customer loss for the concerned Operator(s), even during the above-mentioned six (6) month period. For special case where there is a risk for this kind of loss, EPT shall provide the concerned Operator an alternative solution, whereas the costs for the related migration works will not be charged by EPT to the Operator.

3.10 Coordination between the Parties

3.10.1 EPT shall put into place an entity in order to manage provisioning of raw copper in EPT's local loops. This entity will be the single point of contact for the Operator handling questions regarding the operational management of unbundling. This entity will be accessible during Business Hours.

3.10.2 The Operator undertakes to contact only the EPT single point of contact as specified here above and to provide its own single point of contact for the management of unbundling, including for questions regarding operational subjects.

3.10.3 The EPT's and concerned Operator's respective entity being the single points of contact in relation to this RUO and to the provision of the LLU Services are or, as the case may be, will be specified in the concerned LLU Agreement.

3.11 Financial conditions

3.11.1 Applicable tariffs and billing modalities

In compensation for raw copper services and shared access provided by EPT under this RUO, the Operator shall pay the tariffs specified in Schedule 8 – Tariffs. Billing procedures are or, as the case may be, will be described in the LLU Agreement between the concerned Operator and EPT.

3.11.2 Bank guarantee

The Operator will, at EPT's request, provide for an irrevocable and unconditional bank guarantee on first demand issued in EPT's favour by a first rank EU financial institution for an amount of 50.000,- €. The guarantee shall be issued for a period at least equivalent to the duration of this RUO.

3.11.3 Reasonable doubts on an Operator's creditworthiness

When, and as long as serious and ascertained doubts exist regarding the creditworthiness or solvency an Operator's, EPT may without prejudice to previous arrangements require payment in advance.

3.12 Relations with end-Users and branding

3.12.1 End-Users

Without prejudice to the applicable regulatory framework, EPT will not undertake customer handling/care of the Operator's End-Users.

3.12.2 Branding

The Parties agree not to offer any service under any brand, including any trademark, trade name or company name of the other Party unless the use of the brand(s) of the other Party is expressly agreed upon in writing between the Parties. Such use of the brand will then be strictly limited to the service at stake..

EPT is allowed to use, for all interventions in the context of this RUO, its normal vehicles and staff uniforms with all advertising on them as for its own products and services.

Neither the Operator nor EPT is allowed to attach any branding or advertising signs on each other's equipment and infrastructure, neither in the sites or the End-User's site.

4 Property rights

All relevant EPT Infrastructure used for the provisioning of LLU Services to the Operator remains and shall remain the integral property of EPT.

With the cessation of LLU Services by the Operator, whatever the reason, any usage rights of the Operator on that relevant EPT Infrastructure will automatically expire on the effective cessation date of the LLU Services.

If an End-User terminates the telecommunication service(s) provided by the Operator by means of the MPF, the Operator shall submit a handback order in a time frame of maximum three (3) months and according to the procedure defined in Schedule 7 - Ordering and Provisioning Procedure so that the MPF may then be marked as available for re-use by any other Operator.

5 General terms and conditions

5.1 Confidentiality

- 5.1.1 A Receiving Party shall keep in the strictest confidence all Confidential Information, whichever may be the way or support of its transmission (e.g. in writing, via e-mail or orally) and will not disclose such information to any third party unless the Disclosing Party expressly prior agrees in writing to the release or disclosure of that specific Confidential Information to the said third party. A Receiving Party shall exercise at least the same security level and degree of care than that Party applies to protect its own Confidential Information of an equivalent nature, and in no case less than reasonable care.
- 5.1.2 Confidential Information shall be used by the Receiving Party solely for the purposes for which it was disclosed.
- 5.1.3 The Operator has to inform the End-User that his/her personal data is being transferred to EPT, as specified and/or required by the national data protection legislation.

5.2 Force Majeure

- 5.2.1 Neither Party shall be liable for any breach of a LLU Agreement or delay in the implementation of any of its obligations under a LLU Agreement caused by a Force Majeure event, i.e. an unforeseeable and irresistible event beyond the Parties' reasonable control and which prevents the performance by the affected Party of its obligations under the LLU Agreement and/or this RUO.
- 5.2.2 For the sake of clarity, the following events shall be construed as being a Force Majeure event, without this list being exhaustive: irresistible and unforeseeable natural phenomena (such as floods, hurricane, lightning,...), war(s), invasion(s), revolution(s), riot(s), governmental act(s), general strike(s) or similar event(s), epidemic(s), major machinery and/or equipment breach, civil works and/or third party's (parties') intervention damaging in whole or in part EPT's network and/or equipment and impacting and/or interrupting any part of the LLU Services and/or related provisioning.
- 5.2.3 The Party affected by a Force Majeure event shall promptly notify the other upon

- occurrence thereof of the estimated extent and duration of such inability to perform its obligations and do its reasonable efforts to mitigate the detrimental consequences of the said Force Majeure event.
- 5.2.4 As soon as reasonably practicable after cessation of the said Force Majeure event, the concerned Party shall notify the other thereof and deliveries under and/or performance of a LLU Agreement shall be resumed without undue delay.
- 5.2.5 If, as a result of a Force Majeure event, the performance by either Party of its obligations under a LLU Agreement is only partially affected, such Party shall nevertheless remain liable for the performance of those obligations not affected by the said Force Majeure event.
- 5.2.6 To the extent that a Party is prevented, as a result of Force Majeure event, from providing all or part of the services or facilities to be provided under a LLU Agreement, the other Party shall be released to the equivalent extent from its obligations to make payment for such services or facilities.

5.3 Limitation of Liability

- 5.3.1 Neither Party undertakes any liability for the acts or omissions of a third party provider of telecommunications services.
- 5.3.2 Neither Party excludes or restricts its liability for death or personal injury caused by its own negligence or liability.
- 5.3.3 Neither Party will be liable to the other for any claims, proceedings or actions brought or made against that Party by an End-User of services provided by that Party.
- 5.3.4 Neither Party shall be liable to the other in contract, tort (including gross negligence or breach of statutory duty) or otherwise for indirect or consequential damage or any other losses of profit whatsoever arising in connection with the execution and/or implementation of a LLU Agreement, howsoever caused.

6 Procedure for reaching a LLU Agreement

LLU Agreements will be negotiated and entered into, based on the standard terms and conditions approved by the ILR, pursuant to and in compliance with the applicable legislation.

These standard terms and conditions will be made available after signature of a non-disclosure agreement.

Requests for entering into a LLU Agreement with EPT under this RUO must be made in writing and per registered mail to the following address:

Entreprise des Postes et Télécommunications

Direction Générale

L-2020 Luxembourg

Tel: +352 47 65 1

Fax: +352 47 51 10

7 Schedules 1 to 10

Schedule 1 - Service Description - Metallic Path Facility

1.1 Description

The Metallic Path Facility (MPF) means a pair of fully metallic continuous unequipped copper wires between EPT's Main Distribution Frame (MDF) at EPT's Local Exchange and the Network Termination Point (NTP) at the End-User's premises, at which point the EPT access network ends. The Metallic Path Facility can be an active loop or a non-active loop, and can also be constructed when an NTP doesn't exist but is technically feasible and has been asked for. (see 3.1.2.)

At the EPT's Local Exchange, the MPFs are terminated at the MDFs. The Operator's access to the metallic wire pairs will be established by connecting tie cables from the MDF to the Handover Distribution Frame (HDF).

The Operator shall gain access to an end-to-end metallic pair in the EPT's access network provided that the required MPF is non-loaded and no active equipment (pair gain system etc) is present in the relevant circuit. It is further required that the metallic pair circuit is existing and can be provided without new construction of physical metallic pair wires in the network.

The construction of new metallic pair circuits is outside the scope of this RUO and shall be subject to commercial negotiations, but a new NTP can be asked by the Operator (on behalf of the end-user) and will be provided by EPT, under this RUO if technically feasible. (see 3.1.2.).

1.2 Types Of Offered Loops

EPT MPF unbundling service concerns copper "local loops".

The term "local loop" is generic as it concerns full local loops (between MDF and users premises) and local sub-loops (between SLCP (generic term also as it can cover any type of connection points in a loop cable (and active equipment) path between MDF and users premises) and users premises).

Operators shall mention EPT the service Type used. It is important for technical purposes that EPT is informed about the service Type used by the Operator to give a service for its end-user , even when this service Type changes overtime.

1.2.1 Narrowband service Type

Narrowband service Type copper local loop or sub-loop shall be defined as copper loop only to be used for the transmission of voice-band signals, signals for which the binary rate is smaller or equal to 160kbit/s or for the transmission of signals using ISDN (Integrated Services Digital Network) basic access line code. Requirements for equipment to be connected are specified in Schedule 5 - Technical specifications for Transmission Equipment In The Local Loop.

1.2.2 Broadband service Type

Broadband service Type copper local loop or sub-loop shall be defined as copper

loop to be used to connect services as xDSL, PRI (Primary Rate Interface), or other services for which the binary rate is higher than 160kbit/s. Requirements for equipment to be connected are specified in Schedule 5 - Technical specifications for Transmission Equipment In The Local Loop.

1.3 Network Termination Points

- 1.3.1 The MPF service included in the LLU Services covers the 2 wire copper circuit, starting from the MDF at the Local Exchange and terminating to the NTP on the End-User's site.
- 1.3.2 The type of NTP depends on the End-User's site:
- In Multi-End-Users' apartment buildings and buildings for large businesses or corporations, the NTP is the cross-connectable distribution box in the building.
 - In one-family houses, the NTP is the first distribution box inside the End-User's house.
- 1.3.3 The End-User, who has full responsibility for repair and necessary extensions, owns the in-house cabling system to the different telephone plugs.
- 1.3.4 In the case of Broadband data transmission, the Operator shall guarantee a proper technical termination of the broadband signals having regards to the in-house cabling, in order to avoid reflections or other negative influences impacting the signals of possible other Operators in the building. In such case, EPT can require centralized splitter installations instead of distributed filters. In any case, all this shall be done based on best present business practices and knowledge.
- 1.3.5 To allow proper fault analysis for MPF with service-migration, EPT agrees to assume testing and measurements to the following end-points at End-User's site:
- If the End-User's site is a multi-End-User's apartment building or multi-tenant building (MDU), this will be the first connected telephone plug inside the apartment.
 - If the End-User's site is a single house, this will be located inside the End-User's site, and will be either a telephone plug or a distribution box.
 - If the End-User's site has a cross-connectable distribution box where multiple pairs are connectable for one End-User, this will always be that distribution box.

1.4 Boundary Conditions And Prerequisites

- 1.4.1 Co-Location is a prerequisite for the implementation of these LLU Services. Provisioning and maintenance of Co-Location Services will be offered by EPT to the Operator as specified in the applicable RCO.
- 1.4.2 The Operator undertakes to receive from the End-User a signed request for each telecommunications service to be provided on a metallic pair in the access network prior to order a MPF.

In case of inconsistency, doubts, audit complaint or dispute with the End-User, EPT may ask to receive a copy of the above-mentioned request, while the Operator shall keep and archive the said request for the minimum time period specified by applicable Luxembourg laws.

- 1.4.3 When ordering one of the types of loop being offered under this RUO, the Operator shall notify to EPT the equipment that it intends to connect to the metallic pair.

EPT may require a certificate from the Operator stating that the equipment duly conforms to the equipment requirements specified in the RCO and in Schedule 5 - Technical specifications for Transmission Equipment In The Local Loop.

The Operator shall only be allowed to use the indicated type of loop for the purpose described in chapter 1.2 - Types Of Offered Loops, and shall in no way use any other type of equipment than the one(s) specified in the order form.

- 1.4.4 EPT shall not support customer handling/care services for the Operator's End-Users. Requests from Operator's End-Users due to inadequate handling of those requests by the said Operator shall be dismissed by EPT, unless otherwise expressly agreed between the Parties.

- 1.4.5 EPT needs and has to ensure the coexistence of all transmission services provided by any Operator on the same cable.

Therefore, the Operator shall comply with the following terms:

- An Operator's request for renting a metallic pair circuit shall always be accompanied by information on the concerned equipment type as defined in Schedule 5 - Technical specifications for Transmission Equipment In The Local Loop, the Operator intends to connect to this metallic pair. In case EPT suspects that the use of the MPF does or may not match the intended use as declared in the order form, EPT shall be entitled to measure the signal over that loop without disturbing the operation of the Operator's network and take all necessary measures to protect the integrity of EPT's network. EPT shall reasonably request in writing the right for all measurements that cannot be done without temporary suspension of the Operator's services, while such authorisation shall not be unreasonably withheld or postponed by the Operator.
- In any case of Operator's changes of equipment/technology used, the Operator shall priority inform EPT thereof in writing in order not to cause any service degradation in EPT's network for other End-Users.
- If equipment or network components operated by the Operator for its own use and connected to EPT's network, cause disturbances in EPT's network, the Operator shall be required to disconnect the End-User's connection and shall proceed therewith without any delay.
- In order to ensure optimal use of the access network in the context of high-speed signals transmission, EPT is applying cable pair management. These rules take into account the characteristics of the access network cables and the spectral compatibility between signals of different technologies as defined

in Schedule 5 - Technical specifications for Transmission Equipment In The Local Loop.

- If the Operator finds out that a fault was caused by conditions or circumstances in EPT's network, the Operator shall inform EPT thereof without any delay. The Operator shall be responsible for the accuracy of this information and support consequently any costs related to any EPT's unnecessary intervention.

1.5 Provisioning and Cessation

The Schedule 7 - Ordering and Provisioning Procedure describes the procedures applicable to MPF provisioning, combined provisioning of MPF and number portability and MPF cessation.

Schedule 2 - Service Description - Sub-Loop Unbundling (SLU)

2.1 Description

2.1.1 These products have been developed to meet EPT's obligations under the EU Regulation (EC) No. 2887/200 on unbundled access to the Local Loop referred to in Article 1.7 of this RUO, while Sub-Loop Unbundling (SLU) means the provision to an Operator of the access to a partial local loop connecting the Network Termination Point (NTP) at the End-User's premises to a Sub Loop Connection Point (SLCP) in the local network. Those SLCPs are defined in a separate document published on EPT's Website.

Such SLCPs or new concentration points do exist in buildings and in indoor or outdoor Shelters. The connection between the SLCP and the Operator's equipment shall be achieved with external tie cables installed by EPT.

In order to accommodate the additional cable terminations, EPT may need to adapt, rebuild or replace the existing SLCP cabinet as far as this is possible under the given local circumstances. The costs of this work shall be born by the Operator requesting access to that SLCP.

2.1.2 Information concerning existing SLCPs in concentration points is published on EPT's Website.

2.1.3 All equipment connected to Sub-Loops shall comply with the specifications defined in Schedule 5 - Technical specifications for Transmission Equipment In The Local Loop.

2.1.4 It is to be stressed that the deployment of ADSL and VDSL electronics is particularly sensitive to cross-talks. Especially in case where the same copper cable between the SLCP and the End-User's premises is used to carry and provide DSL services from the CO and DSL services provided from the SLCP, the near-far cross-talk has a negative influence on the DSL services deployed from the CO.

In order to ensure that all Operators have an equal opportunity to provide DSL services to a given location, it will be necessary to protect the DSL services provided from the CO by applying PSD shaping to the DSL services provided from the SLCP.

Details and specifications of the PSD -shaping to be applied by each Operator, including EPT, are specified in Schedule 5 - Technical specifications for Transmission Equipment In The Local Loop. These PSD rules shall be strictly applied and complied with by all Operators deploying DSL electronics and/or DSL services in any other points of EPT's copper network than the CO.

2.2 Types Of Sub-Loops Offered

The Sub-Loops offered under this RUO are of the same types as the ones

specified for the MPF in Schedule 1 – Service Description – Metallic Path Facility.

2.3 Network Termination Points

NTPs at the End-User's premises are defined in the same way as specified in Schedule 1 – Service Description – Metallic Path Facility.

2.4 Boundary Conditions And Prerequisites

The conditions and prerequisites defined in Schedule 1 – Service Description – Metallic Path Facility shall *apply mutatis* to SLU, except that Co-Location Services are not a prerequisite for SLU-services. For the connection of Operator's equipment to the SLCP, an Operator-specific external tie cable shall be provisioned by EPT.

2.5 Provision Of SLU

The rules specified for the MPF in Schedule 1 – Service Description – Metallic Path Facility shall apply *mutatis mutandis* to SLU.

2.6 Backhaul Connections in the context of SLU

2.6.1 Generalities

EPT shall offer to the Operator, under this RUO regulatory environment, either (choice is to be made by the Operator) (i) an access to a spare duct or (ii) a x Gb (x is to be chosen by the Operator) transmission capacity, between the Operator's RT installed in the boundary of this SLCP and the Co-Location Equipment Room in the serving CO.

If the Operator chooses for a spare duct (DSS see 2.6.3.) and this spare duct is not available, EPT shall offer to the Operator a fibre pair. (BFL see 2.6.4.)

In any case, EPT underlines that the EPT's commercial offers are always available for the Operators and that EPT shall strictly follow the rule of non discrimination. In these cases, an Operator is to be considered by EPT as a business client which has all rights to order every element of the commercial EPT portfolio.

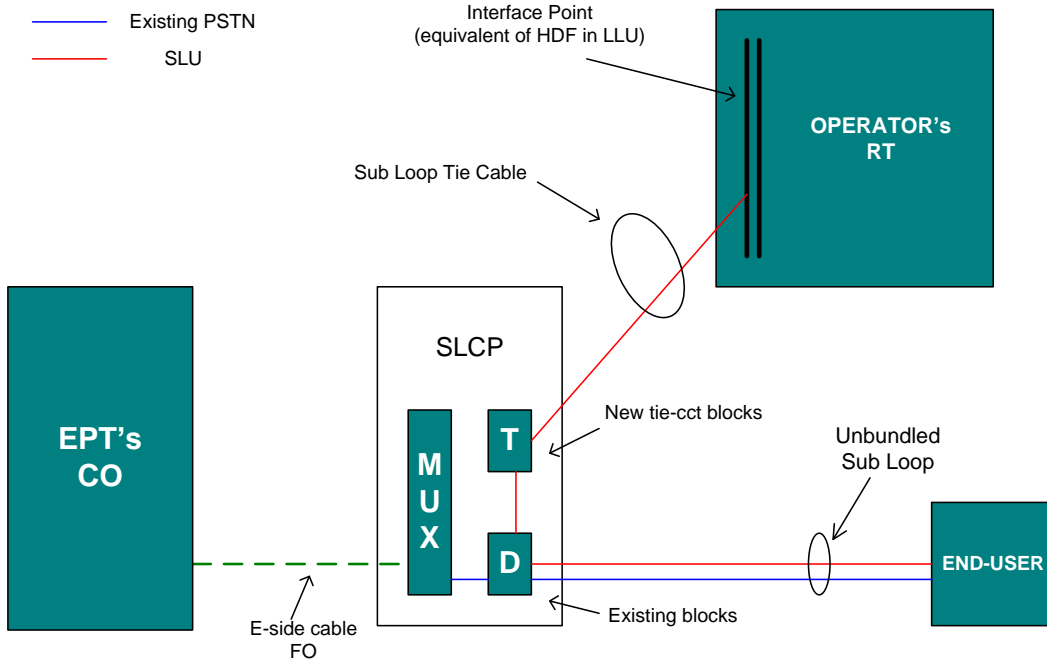

2.6.1.1 A (always up to date) list of the SLCPs without an available copper connection to the MDF (E-side), including their physical addresses, is published on EPT's Website.

2.6.2 BTC Services. (Backhaul Transmission Capacity)

2.6.2.1 Product Description

The BTC Service offered by EPT to the Operator under this RUO is a x Gigabit-Ethernet (GbE) unsecured point-to-point connection delivered by EPT between a given Operator's RT, installed in the boundary of EPT's SLCP and the Operator's presence in the Co-Location Equipment Room installed at the CO serving this SLCP. The x Gigabit-Ethernet will be delivered to the Operator through a single mode 1310nm fibre interface.

2.6.2.2 Boundary conditions and prerequisites

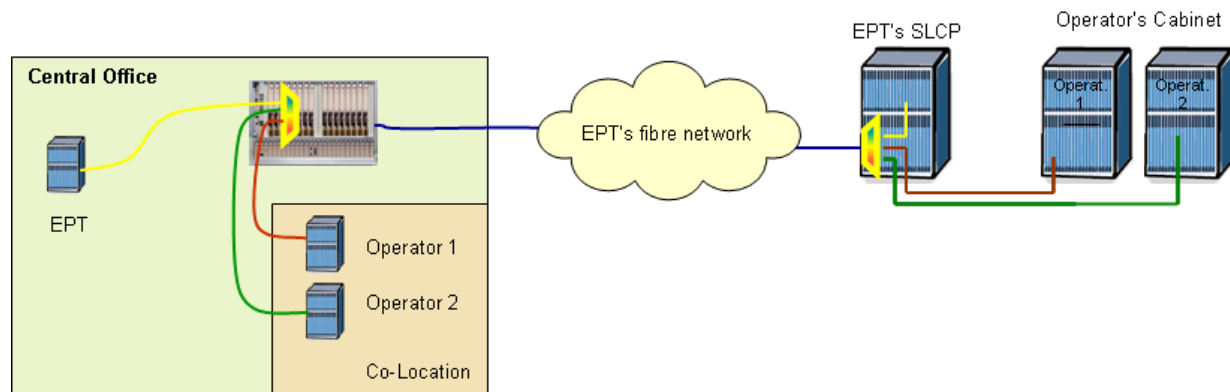

A prerequisite to provide BTC Services is the existence of spare fibre connections between EPT's fibre distribution frame in the CO and the

Operator's Co-Location Space(s) in the Co-Location Equipment Room.

These fibre connections will be installed by EPT, while the related costs (fully proved by EPT) shall be charged to the Operator.

At the SLCP level, the Operator shall provide a spare duct or arrange for the required civil works to deploy the fibre connection between the SLCP and the concerned Operator's RT.

2.6.2.3 General Responsibilities

EPT is responsible for the installation and maintenance of the fibre connections and provisioning of the end-to-end transmission capacity.

The Operator shall be fully responsible for any loss, theft or destruction of, or damage to EPT's equipment located in the accommodations provided by the Operator.

In case of problems in relation to the BTC Services, EPT is entitled to request to the Operator a temporary access to the end-points of the concerned BTC in the Operator's accommodations, all this free of charge.

2.6.2.4 Provisioning and Cessation

Ordering and provisioning shall be handled in compliance with Schedule 7 - Ordering and Provisioning Procedure.

2.6.2.5 Terms and conditions

BTC Services shall be provided for a minimum one (1)-year lease period as from the date of their respective RFS as specified by EPT to the Operator. After expiry of this 1st year, the Operator may cancel the BTC Services upon a one (1)-month prior written notice.

The applicable tariffs are specified in Schedule 8 – Tariffs.

In case the existing SLCP has to be moved or ceased due to external constraints or to modifications to EPT's network structure, the Operator shall bear the costs related to the changes on the BTC infrastructure between the SLCP and the concerned Operator's RT.

In any such cases, EPT shall not be liable nor be held liable to pay any compensation or indemnity to the Operator.

2.6.3 Duct Sharing Service (DSS)

2.6.3.1 Product Description

The DSS offered to the Operator will be a dedicated duct with an inside

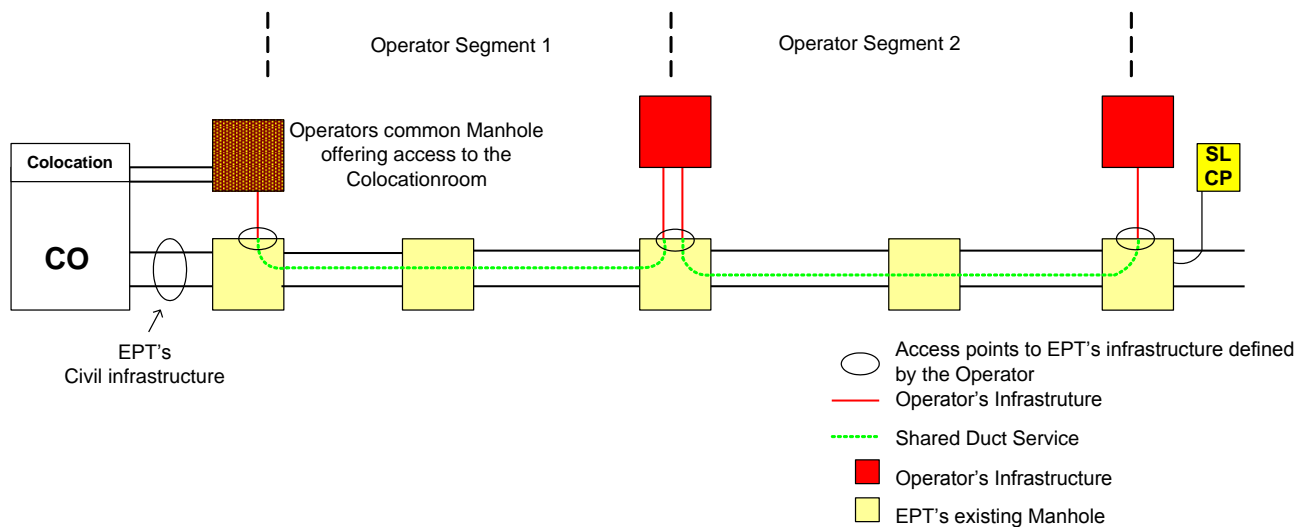

diameter of $\pm 30\text{mm}$ allowing the Operator to draw in either (i) a classical cable or (ii) micro-tubes for optical fibres.

Upon a positive answer to a request as referred to in point 2.6.3.4 below, EPT will provide the Operator with a map showing the routing of the concerned duct of EPT Infrastructure between the CO and the specific SLCP.

When placing an order for a DSS, the Operator shall specify the required access points to EPT Infrastructure.

All infrastructure and equipment needed by the Operator to access EPT's Infrastructure shall be provided by the Operator at his own costs and under his own responsibility.

In any case, it is not permitted to install any Operator's equipment within EPT Infrastructure, except in EPT's Co-location Equipment Room(s). The 30mm inside diameter duct provided by EPT will offer to the Operator an end-to-end connection between the access points defined by the Operator for the different segments.

The connection between the Operator's infrastructure and the EPT's duct shall be and remain under the Operator's sole responsibility. Any and all works affecting directly EPT Infrastructure shall only be carried out after prior EPT's express authorization and shall be supervised by EPT's staff present on the works site, it being specified that such supervision shall be billed on a per hour basis to the Operator. The applicable tariffs are specified in Schedule 8 – Tariffs.

2.6.3.2 Boundary conditions and prerequisites

The DSS offer shall be expressly limited to the availability of existing spare capacity between the SLCP and the CO. EPT shall not be responsible for expanding, modifying and/or conditioning in any way EPT Infrastructure to provide DSS to other Operators, and EPT shall in no case be obliged thereto.

In any case, at least one (1) duct shall be kept vacant as a maintenance duct

and as an alternative to any damaged one(s).

A request for DSS may be rejected if there is no other space capacity available than those defined here above, or for safety, reliability or short-term forecast needs. Sharing shall be based on practicability, technical feasibility and availability.

Any damages that may occur to EPT's facilities during installing, operating, maintaining the Operator's equipment shall be born by the Operator.

EPT shall not be responsible for any damages that may occur to the Operator's equipment due to a Force Majeure event.

The procedures specified in Schedule 6 – Planning and Operation shall be complied with by the Parties.

2.6.3.3 Cable Works by the Operator

Prior to any drawing of micro-tubes or cables through the duct provided by EPT, the Operator shall inform EPT of the planned works. This information shall be submitted by e-mail to EPT at the following address: Projection_Extension@ept.lu at least five (5) working days before the date planned for the cable works.

If, in EPT's reasonable opinion, such works could reasonably (i) seriously affect or (ii) have major impact on EPT's existing services or installations, the cable works shall only be realized in the presence of EPT's staff, while such EPT's presence will be billed on a per hour basis. The applicable tariffs are specified in Schedule 8 – Tariffs.

In addition, the Operator shall ensure and, if appropriate, cause that any instructions given in relation thereto by EPT's staff shall be timely and duly complied with throughout the works.

2.6.3.4 Ordering and Provisioning

Ordering and Provisioning will be handled as specified in Schedule 7 - Ordering and Provisioning Procedure.

2.6.3.5 Terms and conditions

DSS shall be provided for a minimum one (1)-year lease period. After expiry of this 1st year, the Operator may cancel the DSS upon a one (1)-month prior written notice.

Prior to and in any case at the latest upon the effective termination date of a DSS, the Operator shall have removed all the cable(s) and/or micro-tube(s) it used in relation to the terminated DSS and have effectively returned the concerned duct to EPT in its original state. Failing to do so properly and in due time, EPT shall be entitled to substitute directly or indirectly to the Operator, at the Operator's costs, to proceed with such obligations and to remove all cable(s) and/or micro-tube(s) still located in the concerned duct and/or to repair the concerned duct to make it complete and/or in its initial state.

The applicable tariffs are specified in Schedule 8 – Tariffs.

In case the existing infrastructures (being either EPT's and/or Operator's ones) have to be moved or ceased in whole or in part due to external constraints or to EPT's decision to cease a given duct segment, the Operator shall bear the costs related to the changes on its infrastructure.

In any such case, EPT shall not be liable nor be held liable to pay any compensation or indemnity to the Operator.

2.6.4 **BFL Services. (Backhaul Fibre Link)**

2.6.4.1 Product Description

The BFL Service offered by EPT to the Operator under this RUO is a fibre pair (single mode 1310nm) unsecured point-to-point connection delivered by EPT between a given Operator's RT, installed in the boundary of EPT's SLCP and the Operator's presence in the Co-Location Equipment Room installed at the CO serving the said SLCP.

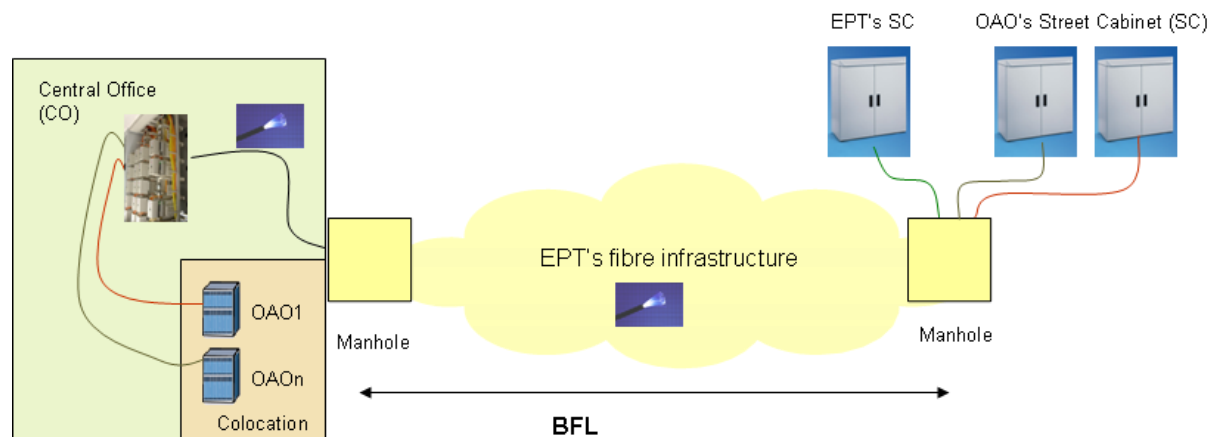

2.6.4.2 Boundary conditions and prerequisites

This BFL Service offer shall be expressly limited in strict relation to SLU and:

- to situations where DSS is not available and
- to the availability of existing spare capacity between the Manhole in SLCP and the CO, while EPT shall in no case be responsible for expanding, modifying and/or conditioning in any way EPT Infrastructure to provide BTC Service to other Operators, and EPT shall in no case be obliged thereto. Anyway, EPT shall always cooperate to find a suitable solution to fulfil its non discriminatory

obligation.

A prerequisite to provide BFL Services is the existence of spare fibre connections between the SLCP and the concerned Operator's RT as well as between EPT's fibre distribution frame in the CO and the Operator's Co-Location Space(s) in the Co-Location Equipment Room.

These fibre connections will be installed by EPT, while the related costs shall be charged to the Operator.

At the SLCP level, the Operator shall provide a spare duct or arrange for the required civil works to deploy the fibre connection between EPT's fibre Infrastructure and the concerned Operator's RT.

2.6.4.3 Ordering and Provisioning

Ordering and Provisioning will be handled as specified in Schedule 7 - Ordering and Provisioning Procedure.

2.6.4.4 Terms and conditions

BFL shall be provided for a minimum one (1)-year lease period. After expiry of this 1st year, the Operator may cancel the DSS upon a one (1)-month prior written notice.

The applicable tariffs are specified in Schedule 8 – Tariffs.

In case the existing infrastructures (being either EPT's and/or Operator's ones) have to be moved or ceased in whole or in part due to external constraints or to EPT's decision to cease a given fibre segment, the Operator shall bear the costs related to the changes on its infrastructure.

In any such case, EPT shall not be liable nor be held liable to pay to the Operator any compensation or indemnity whichever may be the reason in relation to the above.

Schedule 3 - Service Description - Shared Local Loop Service (SLLS)

3.1 Description

- 3.1.1 The SLLS product allows a voice service provided by EPT, and an xDSL service offered by the Operator, to be integrated into the same 2 wire copper pair.
- 3.1.2 SLLS shall only be offered on a Local Loop where EPT is already supplying the relevant End-User with analogue telephone service or ISDN-BRA service; provided that the required MPF is non-loaded and that no active equipment (pair gain system, etc) is present in the relevant circuit. SLLS in the case of SLU has to be specifically analysed on a case by case basis.
- 3.1.3 If an End-User disconnects EPT's retail PSTN/ISDN service, EPT will initiate action to disconnect the PSTN/ISDN service and will notify the Operator of such a disconnection. SLLS shall then be converted into Broadband-MPF and the tariff for Broadband-MPF shall be applied. The applicable procedure is described in Schedule 7 - Ordering and Provisioning Procedure.

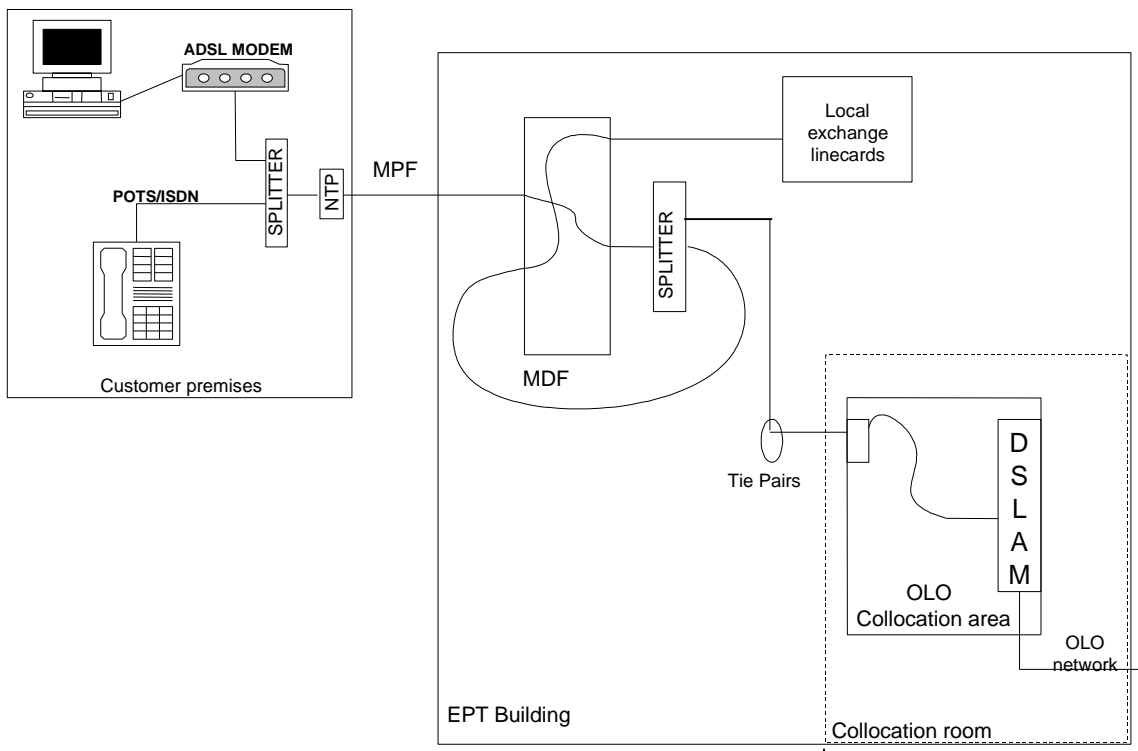

Figure 1: Configuration a) Splitter at End-User's premises (for ISDN or POTS)

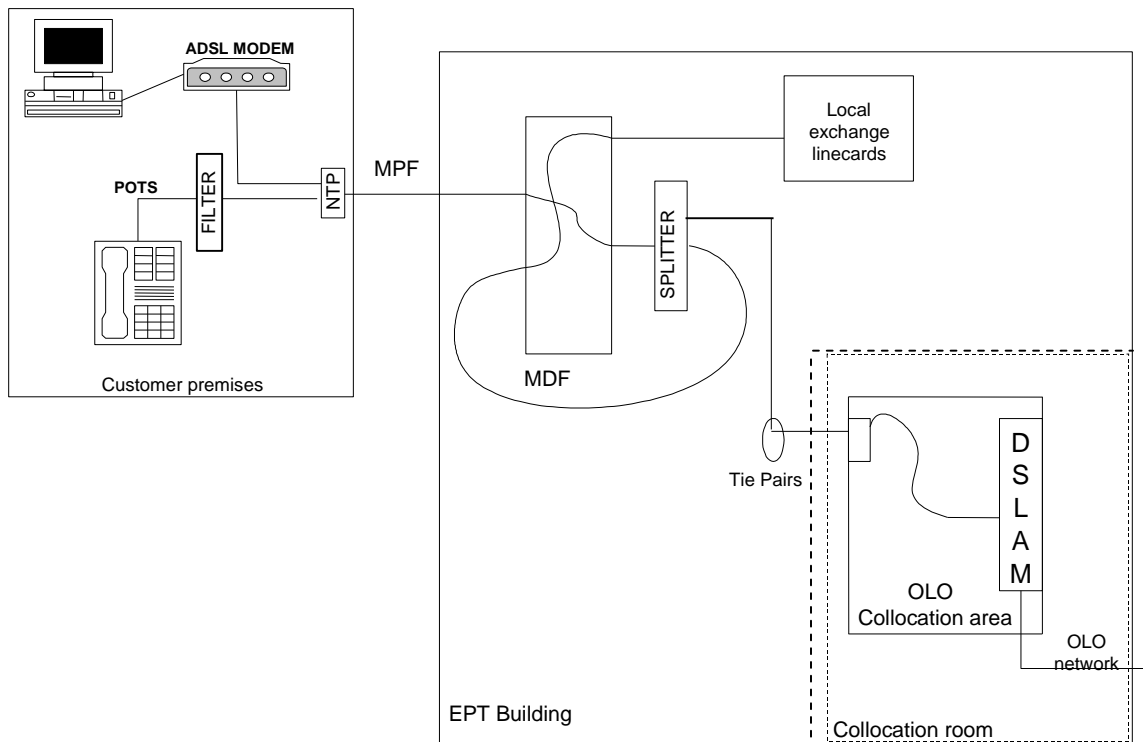

Figure 2: Configuration b) Distributed Filters at End-User's premises (for POTS and best effort services only)

3.2 Types Of Offered Loops

3.2.1 The following types of SLLS are offered under the present RUO:

- SLLS for xDSL over PSTN,
- SLLS for xDSL over ISDN.

3.2.2 Technical information concerning the nature of the signals to be used for each type of Shared MPF is detailed in Schedule 5 - Technical specifications for Transmission Equipment In The Local Loop.

3.3 Network

3.3.1 Splitters and distributed filters

Splitters or distributed filters are required in order to enable EPT's voice band services (PSTN/ISDN) and the relevant Operator-supplied xDSL data services to co-exist on the same copper pair.

Splitters and filters have to be installed as follows:

- **POTS:** Centralised Splitter on MDF side; Filter on End-User's side for best effort services, Splitter on End-User's side for services needing guaranteed

high bandwidth services.

- **ISDN**: Centralised Splitter on MDF side; Splitter on End-User's side.

The line signals of the xDSL service shall comply with chapter Schedule 5 - Technical specifications for Transmission Equipment In The Local Loop.

The Operator shall be responsible for timely ordering tie cables and centralised splitters for the MDF site and splitters or distributed filters for the End-User's site prior to the request of shared pair services for individual End-Users. This ordering process is described in Schedule 7 - Ordering and Provisioning Procedure. The centralised splitters have to be defined as being Splitters for POTS lines or Splitters for ISDN lines. Distributed filters can only be used in case of POTS as described above.

The splitters in the Local Exchange are provided and installed by EPT. At the End-User's premises, the appropriate splitter or distributed filters are installed by the Operator. In order to guarantee compatibility of the network elements installed in the Local Exchange and at End-User's premises, the Operator has to use the splitters and filters provided by EPT.

3.3.1.1 Adapt the in-house cabling at the End-User premises using a splitter.

The Operator shall install an appropriate (POTS or ISDN) centralised splitter at the End-User's premises, while EPT's responsibility shall terminate in any case at the NTP.

The Operator shall be entitled to connect the necessary cabling between the splitter and the broadband xDSL-modem to the splitter interface.

In case the quality of the existing in-house cabling between the splitter and the broadband modem is insufficient to carry high bit rate traffic, the Operator shall be responsible for providing an appropriate link on the concerned section.

The Operator shall in no way be allowed to (i) disconnect any narrow-band equipment or to (ii) change their functionality without the express End-User's acknowledgement.

If the connection of the Operator's equipment to the splitter interface is disturbing any End-User's narrow-band service, EPT will disconnect the equipment at the splitter level and inform the Operator thereof. This intervention by EPT shall be considered as a wrongful repair request and be billed as a consequence at the corresponding rate to the Operator. It is the Operator's obligation to clear the fault before reconnecting to the splitter interface, to avoid any impairment on the narrow-band service.

3.3.1.2 Adapt the in-house cabling at the End-User premises using distributed filters

In case of POTS, distributed filters can also be used instead of a splitter for best effort services. Those are located between each narrow-band telephone service device and the remote in-house points. EPT's responsibility shall terminate in any case at the NTP.

Based on increased bandwidth and guaranteed service offers, EPT can require in MDU's that centralised splitters have to be installed by the Operator to avoid

cross-talk based on bridged-taps.

The Operator has the right to connect the End-User's premises equipment (or CPE) directly to the remote in-house point. If the quality of the existing in-house cabling is insufficient to carry high bit rate traffic, it shall be the Operator's responsibility to provide an appropriate cabling infrastructure.

The Operator is in no case allowed to disconnect any narrow-band equipment or change their functionality without the End-User's prior acknowledgement.

If the connection of the Operator's equipment is disturbing any End-User's narrow-band service, EPT will disconnect the equipment and inform the Operator thereof. This intervention by EPT shall be considered as a wrongful repair request and shall be billed as a consequence at the corresponding rate to the Operator. It will be the Operator's obligation to fully clear the fault before reconnecting the CPE, to avoid any impairment on the narrow-band service.

3.3.2 Network termination points

The SLLS shall terminate in the Local Exchange at the high frequency interface of a CO splitter and in the End-User's premises at the high frequency interface of the splitter or on the telephone plug of End-User, where the Operator's equipment is connected.

At the End-User's premises, the Operator shall access the shared line at the high frequency interface of the splitter or, in case of distributed filters, at the telephone plug. The (i) provision and installation of (i) the End-Users' wiring for the xDSL services, in accordance with Schedule 5 - Technical specifications for Transmission Equipment In The Local Loop and of any equipment to provide xDSL services as well as the (ii) replacement or changes to the existing End-Users' wiring to install the appropriate equipment shall be the Operator's sole responsibility.

At the Local Exchange, the copper wires are terminated at the MDF. A wire connection is used to connect the Local Loop from the MDF to the splitter rack. The low frequency is connected from the splitter through the MDF to the EPT's switch for providing EPT's ISDN or PSTN service. Operator's access to the SLLS (high frequency) will be established with tie cables for broadband usage from the Splitters to the Operator's Co-Location area in that same EPT's building.

3.3.3 Spectrum Management and Equipment compatibility

Requirements related to spectrum management and the equipment connected to the SLLS are described in Schedule 5 - Technical specifications for Transmission Equipment In The Local Loop.

3.4 Boundary Conditions And Prerequisites

3.4.1 Co-Location Services are a prerequisite for the implementation and provision of LLU Services. Provisioning and maintenance of Co-Location will be offered by EPT in compliance with the terms and conditions of the applicable RCO.

3.4.2 SLLS can only be requested by an Operator to provide xDSL services to the same End-User that has contracted POTS/ISDN services with EPT on that same

MPF.

- 3.4.3 No sub-letting or sharing of the SLLS provided by EPT shall be permitted.
- 3.4.4 The MPF used for providing SLLS remains and shall remain EPT's property.
- 3.4.5 The SLLS shall only be available where EPT continues to use the Local Loop to provide the POTS/ISDN service to the End-User.
- 3.4.6 EPT needs and has to ensure the coexistence of all transmission services provided by the different operators and Operators on the same cable.

Therefore, the Operator must comply with the following terms:

- An Operator's request for SLLS shall always be accompanied by information on equipment type as defined in Schedule 5 - Technical specifications for Transmission Equipment In The Local Loop of the equipment that the Operator intends to connect to this shared access. In case EPT suspects that the use of the SLLS does not match the intended use as declared in the order form, EPT shall be entitled to measure the signal over the tie cable without disturbing the operation of the Operator's network and take all necessary measures to protect the integrity of EPT's network. EPT shall reasonably request in writing the right for all measurements, which cannot be done without temporary suspension of the Operator's services, while such authorisation shall not be unreasonably withheld or postponed by the Operator.
- In any case of Operator's changes of equipment/technology used, the Operator shall priority inform EPT thereof in writing in order not to cause any service degradation in EPT's network for other End-Users.
- If equipment or network components operated by the Operator for its own use and connected to the EPT's network, cause disturbances in EPT's network, the Operator shall be required to disconnect the End-User's connection without any delay and shall proceed therewith without undue delay.
- In order to ensure optimal use of the access network in the context of high-speed signals transmission, EPT may apply pair selection rules. These rules take into account the characteristics of the access network cables and the spectral compatibility between signals of different technologies as defined in Schedule 5 - Technical specifications for Transmission Equipment In The Local Loop.
- If the Operator finds out a fault was caused by conditions or circumstances in EPT's network, the Operator shall inform EPT thereof without any delay. The Operator shall be responsible for the accuracy of this information and shall support consequently any costs related to any EPT's unnecessary intervention.

3.5 Provisioning and Cessation

The procedures for SLLS provisioning and cessation are described in Schedule 7 - Ordering and Provisioning Procedure.

Schedule 4 - Service Description - Tie cables

4.1 Internal tie cables

4.1.1 Description

At the EPT Local Exchange, the copper wires are terminated in the MDF. The Operator's access to the copper wire will be established with internal tie cables from the MDF of the Local Exchange to the Operator's Co-Location area in that same EPT's Site.

The Co-Location room may be situated inside the EPT's building or in a container outside the building.

The Operator will order the internal tie cables prior to the request of MPF. The procedure covering forecasts are described in Schedule 6 - Planning and Operation; the ordering process is described in Schedule 7 - Ordering and Provisioning Procedure. If, at a certain point in time, no more free wires are available in the internal tie cables, the specific orders for MPF will be rejected.

The internal tie cables will be supplied in increments of 100 pairs. The type of cable provided is twisted pair broadband cable.

4.1.2 Boundary conditions and prerequisites

Co-Location is a prerequisite for the implementation of these LLU Services. As long as an Operator does not have approved Co-Location facilities, no order for internal tie cables can be executed.

The Operator shall provide, at its own expenses, in the specified Co-Location area, suitable accommodation for the EPT's equipment associated with the internal tie cables.

The internal tie cable will have, associated with it, termination blocks provided by EPT. The termination blocks are installed at the MDF and at the HDF provided by the Operator. The HDF is for the sole use of the Operator within the specified Co-Location area.

Internal tie cables for voice-band or narrow-band data will be terminated on LSA-plus connection blocks with a possibility to disconnect or to do intrusive measurement

All installations shall be done by EPT or by EPT's subcontractors. The routing of the internal tie cables shall be at EPT's sole discretion.

EPT shall be responsible for the installation and maintenance of the cable and termination blocks. The handover point shall be the termination block on the HDF.

The Operator shall be solely responsible for any loss, theft, destruction of, or damage to EPT's equipment in the accommodation housing the internal tie cable at the accommodation provided by the Operator, howsoever caused, occurring at any time while such EPT's equipment is so located.

For normal provisioning, EPT does not need to intervene on the HDF termination blocks. Therefore, the Operator is entitled to lock access to the HDF.

In case of presumed interference or other problems on the tie cable as described in Schedule 6 - Planning and Operation, EPT may request the Operator to enable temporary access to a locked HDF at no expense for EPT.

4.1.3 **Provisioning And Cessation**

The procedure for internal tie cables provisioning is described in Schedule 7 - Ordering and Provisioning Procedure.

4.2 **External tie cables**

4.2.1 **Description**

External tie cables are used to connect the Operator's HDF to the MDF in case of Distant or Adjacent Co-Location.

The Operator will order the external tie cables prior to the request of MPF. The procedure covering forecasts are described in Schedule 6 - Planning and Operation; the ordering process is described in Schedule 7 - Ordering and Provisioning Procedure. If at a certain point in time, no more free wires are available in the external tie cables, the specific order for MPF will be rejected.

The external tie cables will be supplied in increments of:

- 100 pairs in principle,
- 50 pairs in case of SLLS

The type of cable to be provided is non-shielded twisted pair cables of 0,5 mm gauge; EPT's rules for Cable Pair Management shall apply.

4.2.2 **Boundary conditions and prerequisites**

4.2.2.1 **Co-Location in a Shelter adjacent to existing EPT Site**

The Operator shall provide, at its expenses and at the shelter provided by the Operator, suitable accommodation for the EPT equipment associated with the External tie cables. The external tie cables will be associated with the termination blocks provided by EPT. The external tie cables will be terminated at the MDF and at the HDF on the termination blocks installed in the Operator's Co-Location Space. The ironwork of the Distribution Frame is to be provided by the Operator and shall be of sufficient size and of relevant specification to enable EPT to fix all termination blocks of the ordered external tie cables.

External tie cables for voice-band or narrow-band data will be terminated on LSA-plus connection blocks with a possibility to disconnect or to do intrusive measurement.

4.2.2.2 **Co-Location in an Operator owned distant location site**

Distant Co-Location is the service according to which EPT offers an extension

of the tie cables from the MDF in an EPT's technical building to the first existing manhole on the boundary of EPT's premises for the purpose of junction with the Operator's cabling for LLU Services. EPT will indicate to the Operator the point of interconnection between Operator's infrastructures and EPT Infrastructure, e.g. the first existing manhole on the public domain outside EPT-MDF premises.

EPT shall bring tie cables from a dedicated block on the MDF through the external EPT's cable ducts to the hand-over manhole. The splicing in EPT's manhole to connect tie cables to the Operator's cables will be executed by EPT. The related costs shall be charged to the Operator.

4.2.3 **General Responsibilities**

EPT is responsible for the installation and maintenance of the cable and termination blocks. The handover point is the termination block on the HDF at the Operator's site in case of Co-Location in a shelter adjacent to existing EPT's site and the joint in the manhole in case of Co-Location in an Operator's owned distant location site.

The Operator shall be solely responsible for any loss, theft or destruction of, or damage to EPT's equipment located in the accommodation housing the external tie cable at the premises provided by the Operator, howsoever caused,.

In case of presumed interference or other problems on the tie cable, EPT may request the Operator to enable temporary access to the HDF at no expense for EPT.

4.2.4 **Provisioning and Cessation**

The procedure for internal tie cables provisioning is described in Schedule 7 - Ordering and Provisioning Procedure.

4.3 **Tie cables management**

4.3.1 Tie cables shall at all times be filled before a new tie cable is deployed for the provision of additional MPF; the Operator shall be responsible for ensuring this.

4.3.2 The Operator shall therefore submit MPF provisioning for partially filled Tie-Cables in preference to empty tie cables.

4.3.3 In case of capacity constraints on the MDF and partially used tie cables, a rearrangement may need to be performed to de-fragment the use of cables and to eliminate gaps within the tie cable pair allocation thus eliminating unused pairs in excess of 50% of active pairs.

4.3.4 This activity will be done in cooperation with the Operator, while EPT will do the rearrangement, pair by pair, at the MDF and the Operator at the HDF.

4.3.5 EPT will bill this rearrangement activity to the Operator.

Schedule 5 - Technical specifications for Transmission Equipment In The Local Loop

5.1 Introduction

This schedule gives an overview of the existing EPT's access network using unscreened twisted metallic pairs and defines technical specifications applicable to transmission systems to be used on this network.

To ensure the prevention of undue interference between transmission systems used on different metallic pairs in the same access cable, transmission systems (whether provided by EPT, an Operator or an End-Users) connected to metallic pairs of the EPT's access network shall conform to these specifications. References are made to international standards and to EPT's user network interfaces specifications. As new version of the below references may be subsequently published, the reader shall always refer to the most recent version thereof.

In order to enable an efficient use of the access networks for all connected systems, EPT has to limit spectral pollution by applying limits on:

- System diversity (technology mix in the same cable),
- Penetration (number of systems in the same cable),
- Signals (level, spectra).

System diversity and penetration are handled by Cable Pair Management ("CPM"); Signals are handled by Power Spectrum Management ("PSM").

5.2 Cable Pair Management and Network Characteristics

5.2.1 Cable Pair Management

5.2.1.1 Background

To maximize the capability of the systems deployed over the copper network, the effects of their mutual interference shall be minimized. Where there are multiple operators or Operators over the same infrastructure, as in the case of a LLU access network, a CPM is essential in order to:

- Maximise benefits for the End-User,
- Ensure network integrity,
- Achieve a high level of End-User penetration for broadband services,
- Foster the introduction of innovative technology,
- Ensure efficient use of the transmission capacity of the cable,
- Reduce risks of disputes.

The protection of existing services must be guaranteed and account must be taken to the many systems already deployed and their performance must be

protected.

EPT applies a combined CPM and PSM to reduce mutual interference of the different systems due to cross talk between cable pairs in the cable.

As a consequence of the above, the number of broadband systems that can be deployed within an access cable depends on the diversity of systems installed, the spectral interoperability between the different broadband flows and on the characteristics of the cable itself. EPT installs such broadband systems on the cable as long as the quality degradation is acceptable. To identify possible spectral interferences and to enable a high penetration with broadband services in the cables, EPT is testing on a regular basis the state of the art technologies as defined by the telecom industries and supported by the equipment supplier.

CPM does not include in-house networking under the End-User's responsibility. Signals from systems connected to an in-house network may interfere to cable systems either through cross talk between pairs or through leakage back of the system connected to the cable pair.

Any equipment connected directly to a MPF must be CPM compliant.

In some cases, and without the knowledge of or information to EPT, End-Users might have taken advantage of existing opportunities to deploy broadband data systems over analogue leased lines, where simple copper pairs have been established between two premises. In case of identified interference and/or significant performance degradation on other systems, EPT will request immediate removal of those systems that are not compliant to CPM.

5.2.1.2 Enforcement and policing of the Cable Management

Due to the statistical nature of the figures involved (for example, cross talk), the CPM cannot give a guarantee of the performance of a system class over a particular copper pair or prevent harmful interference between transmission systems on the same access network in all cases.

Non-compliance with the CPM also does not necessarily lead to immediately observable service degradation. Detecting and locating systems that are non-compliant with the CPM is a difficult task. Non-intrusive test equipment to allow such detection is currently not generally available. EPT is therefore entitled to operate intrusive testing to identify the interference source.

During fault finding, it might be necessary to include co-operation of all cable users (including Operators), also of those who are not themselves suffering from interference and are not suspect as the interference source. Such support is not subject to any indemnification for the Operators.

If non-compliance is detected in a reliable manner, the disturbing system is to be disconnected from the network immediately. This includes disconnection of End-User's systems and equipment directly connected to the metallic copper pair.

Where it is not possible to locate the disturbing system unambiguously by measurement, EPT will perform a re-arrangement of the broadband pairs in the cable to optimize the distribution of broadband systems in relation to the specific characteristics of that cable. In case satisfying performance cannot be

established by this rearrangement, the "last in-first out" (LIFO) principle will be applied on the cable until a level of performance is reached on the remaining systems, acceptable by all Operators.

As the operation of the "last-in-first-out" could favour a single system operating at the limit of the characteristics at the cost of an optimized broadband utilisation of that cable, an even performance concerning distance and supported bit rate on all remaining systems on the cable should be aimed for. In such a situation, weak performing systems can be eliminated at the benefit of an optimized overall broadband utilisation of the cable.

5.2.2 Network characteristics

5.2.2.1 Generalities

A subscriber loop consists of sections of twisted pairs of cables. All sections are usually composed of underground cables of different physical characteristics, and connected together by means of electrical splices. The underground cables are placed either directly in the ground or sometimes in conduct systems with manholes to give easy access to the joints. Normal aerial cables are generally quite seldom, though overhead drop wire or drop cables are used to connect small agglomerations of houses on rather short distances of 10 to 50 meters to a pole where underground cables terminate.

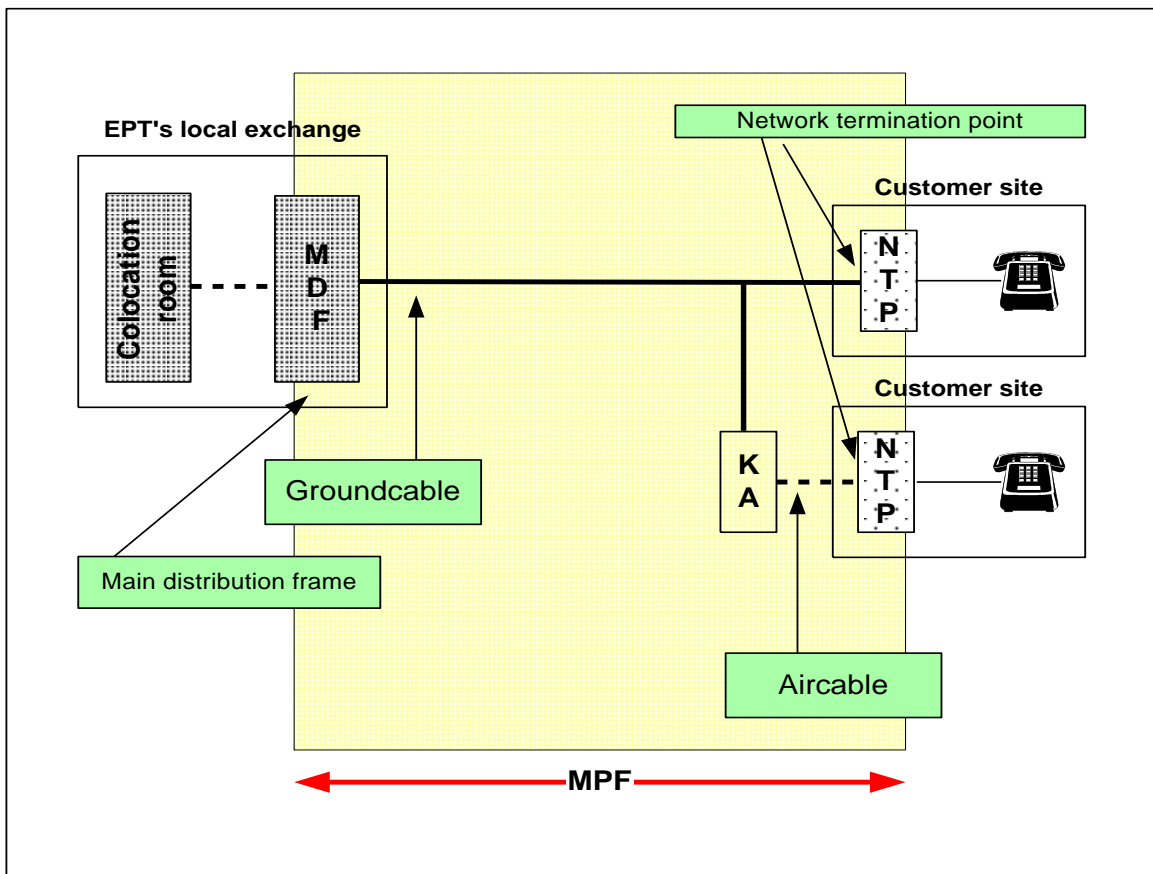

Figure 3: Access Networks

In the ideal situation, the access network has a tree configuration, with up to

three hierarchical levels of branching. A branching node can be a Street Cabinet or any other facility owned by EPT. Every branching node offers the possibilities to manually cross-connect (or jumper) the twisted metallic pair of the feeder cable to any metallic pair in the distribution cables. In a branching node, the total number of metallic pairs of the feeder-cable is substantially smaller than the sum of those in all the distribution cables, typically a ratio of 1 to 1.6. Branching nodes are potential SLCPs for Sub-Loop Unbundling. The reality shows that cable arrangements can lead to a meshed structure in the feeding network.

All twisted metallic pairs start either at the MDF installed at the Local Exchange in EPT's network or at the SLCP in case of Sub-Loop Unbundling.

The distribution cables terminate on the NTPs in the individual End-User's sites. The NTP is a rather small connector box installed inside the End-User's facility at the entering point of the underground cable or the drop wire cable in the End-User's premises.

Occasionally, the NTP can be attached on the outside of a wall of the End-User's site.

During the last years, EPT has introduced the FTTC/FTTB technology, which means that optical fibres have been laid out between the MDF (in EPT's Local Exchange) and the curb (FTTC) or even the End-User's premises (FTTB). In these cases, copper pairs may have disappeared on these sections and have remained between the FTTC/FTTB-shelters and the NT's. The shelters are potential SLCPs for Sub-Loop Unbundling.

5.2.2.2 Copper Cable Properties

5.2.2.2.1 Physical characteristics of the cables

Each telecom copper cable consists of a number of copper conductors grouped in quads. The quads can be arranged in bundles or in layers, depending on the type of cable.

The following is to be noted:

- A conductor can be isolated by a layer of paper (in the older generation cables) or by foam skin polyethylene.
- Most of the conductors have a 0.4 mm or 0.5 mm diameter. Distant customers, however, need to be connected via conductors of 0.6 mm and 0.8 mm.
- Number of pairs may be ranged from 6 pairs in distribution cables ending to private homes up to 2000 pairs in feeder cables going out to the CO.
- To achieve water and vapour sealing, the conductors are surrounded by an alum-polyethylene sheath in the plastic insulated cables and by a lead sheath in the paper insulated cables.
- The plastic cables are longitudinally watertight through a petrogelat filling.

- An armouring protects ground cables.

5.2.2.2.2 Electrical characteristics of the cables

The table below gives some typical characteristics of the access network cables (figures taken from EPT's call for offers to be guaranteed by the cable manufacturers).

Diameter	LR	KC	A800
0.4 mm	300	50	1,55
0.5 mm	192	52	1,25
0.6 mm	130	40	0,95
0.8 mm	73,2	40	0,75

LR= Loop Resistance in ohm/km measured with direct current

KC= maximum Kilometric Capacity in nF/km measured at 800 Hz

A800= Attenuation measured at 800 Hz in dB/km

EPT's access network designed initially to provide analogue telephony service respects following specifications:

- DC loop impedance: max. 1200 ohm
- Line attenuation in the loop: max 8,2dB at 800 Hz

In some exceptions, to serve very remote locations, these values might be exceeded.

The insulation resistance of each conductor in the cable in relation to the rest of the conductors (and any shielding) is expected to be at least 500 Mohm in all operating cables.

Please note that all values are indicated for reference purposes only. In field-measurements, they may change.

For example, to measure the attenuation, a loop is made of several pieces of cables and then additional attenuations and reflections due to the splices and the different cable gauges will occur.

5.2.3 Operators' information in case of failure

Subject to detailed procedures to be set up at the latest without undue delay after the entry into force of this RUO, EPT will inform the concerned Operators immediately upon knowledge thereof when problems due to cable fill or other reasons related to CPM are reasonably likely to arise.

5.3 Power Spectrum Management Of The Equipment To Be Connected To The Metallic Path Facility

The document ETSI TR 101 830-1 and EPT's user network interface descriptions are the two main references. When both are mentioned, the values stated in EPT's "User Network Interface"- descriptions apply.

For the present document, the referred schedules from ETSI TR 101 830-1 are based on version V1.3.1 (2002-12). As a new version of the below references may be subsequently published, the reader must always refer to the most recent version.

Other transmission technologies than those referenced hereafter or used by EPT may be used, if compliant with ETSI standards and if their spectral harmlessness with regard to other used technologies by EPT is proven and confirmed by a bilateral agreed field trial on EPT's network.

Due to the statistical nature of the figures involved (for example cross talk), the PSM cannot give a guarantee of the performance of a system class over a particular copper pair or prevent harmful interference between transmission systems on the same access network in all cases.

Non-compliance with the PSM also does not necessarily lead to immediately observable service degradation. Detecting and locating systems that are non-compliant with the PSM is a difficult task. Non-intrusive test equipment to allow such detection is currently not generally available. EPT is therefore entitled to operate intrusive testing to identify the interference source.

During fault finding, it might be necessary to include co-operation of all cable users (including Operators), also of those who are not themselves suffering from interference and are not suspect as the interference source. Such support is not subject to any indemnification for the Operators.

The following requirements are subject to amendments whenever changes to the relevant standards occur.

5.3.1 Requirements for equipment to be connected for Voice or low bit-rate data transmission on MPF

5.3.1.1 Voice band signals

This section covers signals from telephony transmission equipment (e.g. telephones, voice band modems, Faxes, analogue leased lines etc.) on a single wire pair. Unless otherwise specified, the requirements on DTMF-signals (Dual Tone Multi-Frequency), as defined in ETSI_TBR 21, are equal to the voice signal. A signal can be classified as a voice band signal if it is compliant with all sub-clauses below.

Parameter	Requirements
Frequency range	300 Hz to 3400 Hz
Total signal voltage	ETSI TR 101 830-1 Sub-clause 8.1.1.
Peak amplitude	ETSI TR 101 830-1 Sub-clause 8.1.2

Narrow-band signal voltage	ETSI TR 101 830-1 Sub-clause 8.1.3
Unbalance about earth	ETSI TR 101 830-1 Sub-clause 8.1.4
Feeding Power (from the LT-port)	ETSI TR 101 830-1 Sub-clause 8.1.5
Reference impedance Z_R	ETSI TR 101 830-1 Sub-clause 8.1.6
Ringling signal	ETSI TR 101 830-1 Sub-clause 8.1.7 EPT's user network interface description " <i>Caractéristiques de l'interface d'abonné analogique</i> "
Metering signals	ETSI TR 101 830-1 Sub-clause 8.1.8

5.3.1.2 Low bit rate data transmission

This section covers signals that are generated by digital transmission equipment, based on 2B1Q line coding, up to 160 kb/s, including ISDN-BRA and 64 kb/s and 128 kb/s leased lines.

Parameter	Requirements
Total signal power	ETSI TR 101 830-1 Sub-clause 9.1.1.
Peak amplitude	ETSI TR 101 830-1 Sub-clause 9.1.2
Narrow-band signal voltage	ETSI TR 101 830-1 Sub-clause 9.1.3
Unbalance about earth	ETSI TR 101 830-1 Sub-clause 9.1.4
Feeding Power (from the LT-port)	ETSI TR 101 830-1 Sub-clause 9.1.5

5.3.2 Requirements for equipment to be connected for Broadband data transmission copper local loop

5.3.2.1 Symmetrical Broadband

This section summarises symmetrical signals that are generated by digital transmission equipment up to 2,3 Mb/s. These signals are commonly used to carry services like high quality leased lines, with symmetrical bit rates (in up- and downstream directions).

5.3.2.1.1 SDSL PAM16 Signals

This section covers signals, generated by SDSL (Symmetric single pair high bit-rate Digital Subscriber Line) transmission equipment on one wire-pair, based on PAM16 line coding. This sub-clause is based on the ETSI TS 101 524 and ITU-T G.991.2.

A signal can be classified as a "PAM16 signal" if it is compliant with all sub-clauses below. Unless otherwise indicated the following signal specifications apply with a resistive load impedance of 135 Ω and does not apply to the DC remote power feeding (if existing).

Parameter	Requirements
Total signal power	ETSI TR 101 830-1 Sub-clause 10.5.1
Peak amplitude	ETSI TR 101 830-1 Sub-clause 10.5.2
Narrow-band signal power	ETSI TR 101 830-1 Sub-clause 10.5.3
Unbalance about earth	ETSI TR 101 830-1 Sub-clause 10.5.4
Feeding Power (from the LT-port)	ETSI TR 101 830-1 Sub-clause 10.5.5

5.3.2.2 **Asymmetrical Broadband**

This section summarises asymmetrical signals that are generated by digital transmission equipment up to 100 Mb/s, including ADSL1, ADSL2 and ADSL2+ and VDSL2. Asymmetrically means a bit rate in the downstream direction and a significantly lower bit-rate in the upstream direction. The following naming convention is used in the present document:

- Downstream signal limits are mandatory for signals that are injected into an LT-port of the Local Loop Wiring. LT-ports are located at the CO side of the local loop wiring.
- Upstream signal limits are mandatory for signals that are injected into an NT-port of the Local Loop Wiring. NT-ports are located at the End-User's side.

Asymmetrical DSL systems generate different signals in different transmission directions. Reversal of their transmission direction, which means the injection of upstream signals into LT-ports and downstream signals into the NT-ports, will cause a substantial reduction of the maximum reach. Such a reduction is even significant for all asymmetrical DSL systems when only one such system is reversed. Therefore, it is strictly forbidden to reverse the transmission direction.

5.3.2.2.1 xDSL over PSTN

This category covers signals, generated by xDSL transmission equipment. These signals may share the same wire pair with PSTN signals. This clause is based on ETSI TS 101 388, ANSI T1.413 and ITU-T G.992.1 Annex A (ADSL), G.992.3 Annex A (ADSL2), G.992.5 (ADSL2+) and G.993.2 Annex A, Annex H, Annex L and G.993.2 (VDSL2).

A signal can be classified as an "ADSL over PSTN" (actually only for ADSL G.992.1) if it is compliant with all sub-clauses below:

Parameter	Requirements
Total signal power (downstream only)	ETSI TR 101 830-1 Sub-clause 11.1.1
Total signal power (upstream only)	ETSI TR 101 830-1 Sub-clause 11.1.2
Peak amplitude	ETSI TR 101 830-1 Sub-clause 11.1.3

Narrow-band signal power (downstream only)	ETSI TR 101 830-1 Sub-clause 11.1.4
Narrow-band signal power (upstream only)	ETSI TR 101 830-1 Sub-clause 11.1.5
Unbalance about earth (upstream & downstream)	ETSI TR 101 830-1 Sub-clause 11.1.6

The requirements for any PSTN signal operating in the frequency band below xDSL on the same wire pair are defined in section 5.3.1.1 - Voice band signals.

5.3.2.2.2 xDSL over ISDN signals

This category covers signals, generated by xDSL transmission equipment. These signals may share the same wire pair with ISDN signals. This clause is based on ETSI TS 101388 and ITU-T G.992.1 (ADSL), G.992.3 (ADSL2), G.992.5 (ADSL2+) and G993.2 (VDSL2). A signal can be classified as an "ADSL over ISDN" (actually only for ADSL G.992.1) if it is compliant with all sub-clauses below.

Parameter	Requirements
Total signal power (downstream only)	ETSI TR 101 830-1 Sub-clause 11.3.1.
Total signal power (upstream only)	ETSI TR 101 830-1 Sub-clause 11.3.2
Peak amplitude	ETSI TR 101 830-1 Sub-clause 11.3.3
Narrow-band signal power (downstream only)	ETSI TR 101 830-1 Sub-clause 11.3.4
Narrow-band signal power (upstream only)	ETSI TR 101 830-1 Sub-clause 11.3.5
Unbalance about earth (upstream & downstream)	ETSI TR 101 830-1 Sub-clause 11.3.6

5.4 Mixture of CO and RT deployments

The deployment rules, concerning the mixture of CO and RT deployments, as well as of the different xDSL flavours (SDSL, ADSL1, ADSL2, ADSL2+ and VDSL2) are set forth in schedule 5bis.

Schedule 5bis – Deployment rules

Special attention is to be given to deployment rules. Operators and EPT shall follow strictly these rules on a non discriminatory base. In the event of doubt, any problem shall be mentioned by EPT or by concerned Operators to the ILR. When needed, the ILR shall discuss the matters in a special working group before taking a mediation decision in accordance with article 78(6) of the *Loi du 30 mai 2005 sur les réseaux et les services de communications électroniques*, valid for EPT and Operators. EPT shall not change these deployment rules, or implement new ones without explicit approval from the ILR.

These deployment rules are published on EPT's Website covering Operator services.

Schedule 6 - Planning and Operation

6.1 Preliminary exchange of information

EPT will provide to the Operator as soon as reasonably practicable, but not later than T51 from the date of signature of the non disclosure agreement for the LLU Services an internet access address and password to enable the Operator to view:

- The location of MDF Sites,
- A module to find for each postal address the correspondent MDF or SLCP Site,
- A module to find for each phone number if the current route is on copper and, if so, an indication regarding the length of the access line,
- For each MDF Site the type of Co-Location foreseen and the actual status of deployed Co-Location at each location.

The data is provided for the sole purpose of enabling the Operator to consider whether to request services from EPT pursuant to this offer.

6.2 Electronic Information exchange

The exchange of information shall be exclusively done by means of electronic messaging transfer of XML files via Web service in SOAP (Simple Object Access Protocol) format.

To be accepted, the structure of the files transmitted shall comply with EPT's specifications and instructions. For this purpose, a complete documentation describing the Web service / SOAP interface and the procedures for message exchange between an Operator and EPT in relation to LLU Services will be published and timely updated as appropriate on the EPT's interconnect site.

Before the first data transmission can take place, the Operator has to perform transmission tests with EPT. A period of maximum T52 is foreseen between the Operator's declaration of its interest in LLU Services and the first file to be accepted.

6.3 Forecasting

Providing new MPF service to Operators is a very labour intensive activity. The volume of activity depends mainly of the commercial activity of the different Operators without any direct influence of EPT. To allow proper planning of EPT's production capacity and of its work force allocation as well as to respond to the demand within the indicated time limits and to avoid bottlenecks, an accurate forecasting from the historical data of the systems used by EPT and in some cases from concerned Operators of the required provisioning is essential.

- 6.3.1. MPFNP services delivered as provision type « Swap Express » (see chapter 7.3.2.1.) will be realized within a time frame D+3 and D+7 after the positive survey response send by EPT. No appointment has to be taken on the booking manager system. In principle these lines are not

covered by the following forecast rules. Nevertheless, to allow EPT to respect the above mentioned delays, the Operator should inform EPT in advance if the quantity for a given period exceeds by more than 30% (i.e. in case a new collocation site is taken in service by the Operator) the average number of orders placed during the last 3 months period.

- 6.3.2. To dimension its work staff, EPT will use a rolling forecast based on the orders received via the online booking manager system during the last 3 months period. No committed forecasts have to be provided by the Operator or EPT retail. EPT will respect the installation time as specified in chapter 3.4.2 if the deviation of the before mentioned rolling forecast is less than 10%.
- 6.3.3. In case of major problems reported by an Operator EPT will provide, on request, to ILR the detailed figures regarding the Operator orders as well as the orders of EPT's retail branch. In such case, the reason of major variations in the number of orders placed either by an Operator or EPT's retail branch have to be provided, on request, to ILR.
- 6.3.4. In case an Operator foresees a substantial increase of MPF orders, EPT will do every possible effort to respect the installation time as specified in chapter 3.4.2 by increasing the necessary workforce as far as the Operator informs EPT by mail hereof at least 3 months in advance.

6.4 Fault Reporting And Repair

6.4.1 Generalities

Prior to submit a Fault Report, the Operator shall have to ensure that a genuine fault exists and that every effort has been made in advance to check that the fault resides within EPT's area of responsibility.

6.4.1.1 EPT FCP and Operator FCP

The Operator shall send a Fault Report to EPT FCP at the following email address:

BO_ACC_DER@ept.lu.

Upon receipt of a valid Fault Report compliant to the minimum terms set forth in points 6.4.2.1 and 6.4.3.2 below, as applicable, EPT shall send an e-mail to the Operator to inform it first of the Incident Ticket Opening and last of the Incident Ticket Closing.

To do so, the Operator shall provide EPT with an e-mail address for the exchange of such notification messages.

All related phone calls should be directed via the EPT FCP: +352 4991 5868.

Operator's Fault Reports may be addressed to EPT 24/7.

To be valid, a Fault Report shall contain the minimum information and data requested in the below paragraphs according to the LLU Services concerned.

6.4.1.2 Fault clearance interventions

Fault clearance will be performed during Business Hours.

Special conditions and tariffs apply for fault clearance outside Business Hours.

Fault clearance interventions are billed by EPT to the Operator as defined in Schedule 8 – Tariffs.

Fault reporting and repair have to be performed and achieved in compliance with the specific terms, conditions and time schedules specified per type of service in the related paragraphs below.

Upon receipt of a valid Fault Report, EPT will confirm the due receipt thereof and the starting of EPT's fault clearance intervention in relation thereto by sending an Incident Ticket Opening to the Operator.

For the avoidance of doubt:

- (i) only Fault Reports confirmed by an Incident Ticket Opening will be treated; and
- (ii) the time computation relating to EPT's SLA shall start to count as of the date and time of the Incident Ticket Opening and end at the date and time of the related Incident Ticket Closing.

6.4.1.3 Wrongful repair request

A wrongful Fault Report occurs when EPT has done all necessary measurements on the line and test results prove that the quality of the service concerned by the Fault Report is not the cause of service interruption or service degradation.

In case the reported fault does not lie within the scope of EPT's responsibility for

the concerned part(s) of the LLU Services under this RUO or in case of a wrongful Fault Report, all the costs related to works and travelling already performed by EPT in relation to such Fault Report will be charged to the Operator.

6.4.1.4 Feedback on requested repair

In case the Operator contacts EPT in writing about an ongoing repair action related to a Fault Report, EPT will inform the Operator of the current repair status of the said fault. Upon Operator's express request, a report confirmation will be sent by fax or by e-mail.

6.4.2 Fault reporting and repair for MPF

6.4.2.1 Fault reporting to EPT by the Operator

Fault Reports affecting the MPF will be exchanged between the Operator FCP and the EPT FCP.

The Operator shall provide sufficient information with each Fault Report to allow the diagnosis of the reported fault and to enable the progression of the fault until resolution. Therefore, all Fault Reports should be done using a predefined fault report form that can be downloaded from EPT's Website, and fulfil all items referred to in the said form.

Fault Reports are nevertheless also accepted via simple e-mail containing at least the following data:

1. EPT's reference number of the disturbed LLU Services and precise type of LLU Services affected;
2. Contact point and phone number of the concerned End-User;
3. Full address of the concerned End-User;
4. Operator's contact point (including phone and fax numbers as well as e-mail address) for the given Fault Report and related fault clearance;
5. If applicable, specification that the LLU Service(s) affected are covered by a Business SLA and the reference thereof;
6. Precise description of the reported fault; and
7. Date and description of the intervention of the Operator's technician.

The Operator may pass any additional information it considers relevant to the Fault Report while EPT shall not be obliged to use such additional information, whichever may be the reason.

Upon receipt of a valid Fault Report, EPT will send an Incident Ticket Opening to the Operator as well as afterwards the Incident Ticket Closing. This automatically sent notification messages are triggered by the EPT's reference number of the line. If this field is not indicated in the Operator's Fault Report, no Incident Ticket will be sent to the Operator, while the concerned Fault Report will be deemed as invalid.

6.4.2.2 Fault reporting to EPT by the End-User

The Operator has to inform the End-User about the Operator's responsibility and timely communicate the Operator FCP to the End-User in order to prevent any abuse of EPT's support services.

EPT will not accept any Fault Report from the Operator's End-Users. EPT has no obligation to report to the Operator a fault that an End-User would have directly reported to EPT.

6.4.2.3 EPT and Operator liabilities for the fault clearance

The Operator is requested to transmit to EPT all measurement data from tests the Operator has already performed on MPF.

These measurements should include the following items:

- Resistance measurements,
- Capacity measurements,
- Attenuation

In case the Operator encounters problems on DSL services offered through an MPF line, the following additional information is required:

- DSL line synchronous or not synchronous,
- PPPoE OK or not OK,
- DSL bit rate values up/down,
- Noise margin.

If requested by EPT, the Operator shall disconnect the terminal equipment at the End-User's site in order to allow the testing of the MPF. EPT can also request to the Operator a timeframe for isolating the MPF at the HDF in the Operator's Co-Location facilities to do the necessary measurements.

Any Operator's refusal to timely comply with such request will prevent EPT from verifying the concerned LLU Services and the related Fault Report will be deemed as being wrongful. Both parties shall co-operate in good faith to find suitable timings.

If the Operator's Fault Report received by EPT is valid and contains all minimum information requested,, EPT will issue an Incident Ticket Opening and starts fault localization and fault clearance process during normal working hours. Upon detection of a fault on the MPF, EPT will use all reasonable endeavours to repair the fault as soon as reasonably practicable.

As specified in Clause 3.4.1 (i) of the RUO, the fault clearance is to be achieved within T40. The applicable tariffs are specified in Schedule 8 – Tariffs.

The Operator shall cooperate with EPT's reasonable requests in an effort to locate and if possible resolve any fault. EPT reserves the right to contact and make an appointment with the Operator's End-User for repair of the MPF. In case where contact with the End-User is necessary for repair and the Operator failed to give this information, the related Fault Report will be rejected and be deemed as wrongful.

When EPT has sufficient technical proof that the fault has been cleared an Incident Ticket Closing will be sent to the Operator. The Operator may challenge the closing of ticket within 4 working hours. EPT may give the ticket a different status within their systems. Except if the Operator rejects the concerned Incident Ticket Closing within four (4) working hours after receipt, the Incident Ticket and the related Fault Report will be closed automatically by EPT.

Any closing ticket of EPT will contain detailed information on the fault and the resolution.

If the Operator rejects the Incident Ticket Closing as specified above, it shall specifically provide the following information:

- The reason why the Operator reasonably believes that the circuit is unsuitable for use as a MPF,
- Whether or not the Operator believes that the MPF is within the agreed specifications,
- All additional information that the Operator reasonably considers suitable to assist in understanding and diagnosing any underlying fault in the MPF.

The Operator must cooperate with EPT to carry out further tests, even on Operator's equipment when reasonably requested to do so.. EPT may carry out additional works upon the Operator's request and approval, while the costs thereof shall be invoiced to the Operator, only in case of a wrongful repair request.

Both Parties recognize and acknowledge that the fault repair time will commence when EPT issues the Incident Ticket Opening and will end when the Incident Ticket Closing is not rejected by the Operator.

End-Users' liabilities

The Operator shall cause that the concerned End-User(s) will timely grant EPT's field-force access to the NTP within his/her premises as often as this is necessary for the clearance of the concerned fault. In case of any problems, EPT will report this to the Operator, who will have to contact forthwith the End-User and take the necessary arrangements to grant access to EPT.

In case the End-User is absent during EPT's workforce visit, EPT will drop a card in the mailbox requesting the End-User to contact EPT's helpdesk to convene an appointment. In such case, the normal intervention periods cannot be respected and the intervention time computation shall be automatically suspended until the End-User contacts EPT's helpdesk and an arrangement has been achieved for a new visit.

6.4.3 Fault reporting and repair for SLLS

6.4.3.1 Generalities

EPT will be responsible for the repair of the low bandwidth services offered to the End-User. Operator will be responsible for the repair of the high bandwidth services. EPT's responsibility with respect to the repair of the high bandwidth

service is limited to the following equipment installed by EPT, i.e. centralized splitters at the CO, the cabling between the splitter and the HDF as well as the MPF between the MDF and the NTP at the End-User's premises.

Fault reporting to EPT by the Operator

Fault Reports affecting the high bandwidth will be exchanged between the Operator FCP and the EPT FCP.

The Operator shall provide sufficient information to allow the diagnosis of the reported fault and to enable the progression of the fault until resolution. Therefore all Fault Reports shall contain at least the following data:

1. EPT's reference number of the disturbed LLU Services and type of LLU Services affected,
2. Concerned circuit identification number as provided in the SLLS provisioning process,
3. Contact point and phone number of the End-User,
4. Full address of the concerned End-User,
5. Operator's contact point (including phone and fax numbers as well as e-mail address) for the given Fault Report and related fault clearance,
6. If applicable, specification that the LLU Service(s) affected are covered by a Business SLA and the reference thereof,
7. Precise description of the reported fault and all relevant technical details,
8. Date and description of the Operator's technician intervention.

The Operator may pass any additional information it considers relevant to the Fault Report while EPT shall not be obliged to use such additional information, whichever may be the reason.

6.4.3.2 Fault reporting to EPT by the End-User

The Operator has to inform the End-User about the Operator's responsibility and timely communicate the Operator FCP to the End-User in order to prevent any abuse of EPT's PSTN/ISDN support service.

For fault reporting, EPT will receive direct calls from the End-User through the same channels as it already exists for End-User support regarding EPT's PSTN/ISDN services.

According to the content of the End-User's Fault Report, the following scenarios may occur:

- Low Bandwidth Problem: EPT will start the repair process for PSTN/ISDN.
- High Bandwidth Problem: EPT will refer the End-User to the Operator FCP and EPT will not accept any Fault Report concerning the high bandwidth of SLLS from the Operator's End-Users.
- Low Bandwidth Problem and High Bandwidth Problem: both previous scenarios will be executed independently and in parallel.

6.4.3.3 EPT's Fault reporting to the Operator

The Operator has to provide its Operator FCP to EPT in order to enable EPT to pass the Operator FCP contact information to the End-User in case of a High Bandwidth Problem.

EPT has no obligation to report a fault to the Operator in case an End-User is reporting a fault concerning a High Bandwidth Problem.

6.4.3.4 EPT's and Operator's liabilities for the fault clearance

If the Operator's Fault Report received by EPT is valid and contains all minimum information requested, EPT will issue an Incident Ticket Opening and starts fault localization and fault clearance process during normal Business Hours.

As specified in Clause 3.4.1 (ii) of the RUO, the fault clearance is to be achieved within T40. The applicable tariffs are specified in Schedule 8 – Tariffs. If necessary, the Operator is required to disconnect its xDSL service upon EPT's request to enable appropriate measurements of the line. Any Operator's refusal to timely comply with such request will prevent EPT from verifying the lines and the related Fault Report will The Operator shall co-operate with EPT's reasonable requests in an effort to locate and if possible resolve any fault. EPT reserves the right to contact and make an appointment with the End-User of the Operator for repair. In case where contact with the End-User is necessary for repair and the Operator failed to give this information, the repair request will be rejected.

Should the repair activity establish that the Operator connects equipment that is not compliant with the requirements set out in the Schedule 5 - Technical specifications for Transmission Equipment In The Local Loop, or equipment that causes disturbances for EPT and/or for other End-Users in the cables, EPT is entitled to disconnect the SLLS after prior Operator's notification.

In any case of planned maintenance and repair that can affect the SLLS, EPT shall inform the Operator.

If the Operator requests the repair and EPT concludes that Operator's equipment caused the fault, the Operator will be billed for the work done by EPT.

When EPT has sufficient technical proof that a fault has been cleared, an Incident Ticket Closing will be sent to the Operator and the measurement of the fault repair time will automatically cease with that sending.

It has to be stressed that such a notification can only be sent to the Operator for faults reported in writing to the address **BO_ACC_DER@ept.lu**.

Except if the Operator rejects the concerned Incident Ticket Closing within four (4) working hours after receipt, the Incident Ticket and the related Fault Report will be closed automatically by EPT.

Any closing ticket of EPT will contain detailed information on the fault and the resolution.

If the Operator rejects the Incident Ticket Closing as specified above, it shall

specifically provide the following information:

- The reason why the Operator reasonably believes that the circuit is unsuitable for SLLS,
- Whether or not the Operator believes that the SLLS is within the agreed specifications,
- All additional information that the Operator considers as suitable to assist in understanding and diagnosing any underlying fault in the SLLS.

The Operator shall co-operate with EPT to carry out further tests, even on Operator's equipment when reasonably requested to do so.

EPT may carry out additional work at the Operator's request and approval while the costs thereof shall be invoiced to the Operator, only in case of a wrongful repair.

Both Parties recognize and acknowledge that the fault repair time will commence when EPT issues the Incident Ticket Opening and will end when the Incident Ticket Closing is not rejected by the Operator.

6.4.3.5 End-Users' liabilities

The Operator shall cause that the End-User(s) will timely grant EPT's field-force access to the NTP and splitter within his/her premises as often as this is necessary for the clearance of the concerned fault. In case of any problems, EPT will report this to the Operator, who will have to contact forthwith the End-User and take the necessary arrangements to grant access to EPT.

In case the End-User is absent during EPT's workforce visit, EPT will drop a card in the mailbox requesting the End-User to contact EPT's helpdesk to convene an appointment. In such case, the normal intervention periods cannot be respected and the intervention time computation shall be automatically suspended until the End-User contacts EPT's helpdesk and an arrangement has been achieved for a new visit.

6.4.4 Fault reporting and repair for Backhaul Connections in the context of SLU

6.4.4.1 BTC Services

6.4.4.1.1 EPT FCP

Fault Reports in the context of BTC Services are to be issued by the Operator using EPT FCP as described in chapter 6.4.1

6.4.4.1.2 Fault reporting and feedback

Fault Reports affecting the BTC Services will be exchanged between the Operator FCP and the EPT FCP. The fault report should contain at least the following information:

1. EPT's reference number of the disturbed LLU Services and type of LLU Services affected;
2. Exact address of the concerned Operator's Cabinet/Equipment;
3. Operator's contact point (including phone and fax numbers as well as the e-mail address) for the given Fault Report and related fault clearance;
4. Precise description of the reported fault and all relevant technical details;
5. Date and description of the Operator's technician intervention.

The Operator may pass any additional information it considers as relevant to the Fault Report while EPT shall not be obliged to use such additional information, whichever may be the reason.

Upon receipt of a valid Fault Report, EPT will send an Incident Ticket Opening to the Operator as well as afterwards the related Incident Ticket Closing.

6.4.4.1.3 EPT and Operator liabilities for the fault clearance

In case of a fault occurring to any BTC Services supplied by and under control of EPT, EPT shall commence to resolve the fault within 4 working hours after the Operator has opened a trouble ticket through EPT FCP. The Operator shall cooperate with EPT's reasonable requests in an effort to locate and if possible resolve any fault.

Fault clearance outside Business Hours or with priority handling is possible, provided the Operator has prior accepted, for each such intervention, the special fees to be applied as set out in chapter 8.6 of this RUO.

When EPT has sufficient technical proof that a fault has been cleared, an Incident Ticket Closing will be sent to the Operator and the measurement of the fault repair time will automatically cease with that sending. Except if the Operator rejects the concerned Incident Ticket Closing within four (4) working hours after receipt, the Incident Ticket and the related Fault Report will be closed automatically by EPT.

Any closing ticket of EPT will contain detailed information on the fault and the resolution

The Operator must cooperate with EPT to carry out further tests, even on Operator's equipment when reasonably requested to do so. EPT may carry out additional work at the Operator's request and approval. The Operator shall pay EPT's costs for such additional work, only in case of a wrongful repair request..

Both Parties recognize and acknowledge that the fault repair time will commence

when EPT issues the Incident Ticket Opening and will end when the Incident Ticket Closing is not rejected by the Operator.

6.4.4.2 Duct Sharing Services (DSS)

In case of a fault occurring to any DSS supplied by and under control of EPT, EPT shall commence to resolve the fault within four (4) working hours after Incident Ticket Opening further to a valid Operator's Fault to BO_ACC_DER@ept.lu.

EPT will send to the Operator an Incident Ticket Opening and related Incident Ticket Closing.

EPT's intervention on faults shall be strictly limited to EPT Infrastructure. In no case EPT will undertake any fault clearance on the Operator's infrastructure, including the Operator's segments used to access EPT Infrastructure.

In case of a fault on a DSS caused by EPT, EPT will re-establish end-to-end connectivity of the DSS between the access points at its own costs and will arrange, if necessary, with the Operator the reactivation of its services.

In case of a fault on a DSS located within EPT's area of responsibility, caused by a third party, EPT will re-establish end-to-end connectivity of the DSS between access points. All other aspects regarding the reestablishment of Operator's services have to be initiated and controlled by and under the sole Operator's responsibility.

In any such cases, EPT shall not be held liable to pay any compensation or indemnity to the Operator.

6.4.4.3 Backhaul Fibre Link Services (BFL)

In case of a fault occurring to any BFL Service supplied by and under control of EPT, EPT shall commence to resolve the fault within four (4) working hours after Incident Ticket Opening further to a valid Operator's Fault sent to BO_ACC_DER@ept.lu.

EPT will send to the Operator an Incident Ticket Opening and related Incident Ticket Closing.

In case of a fault on a BFL caused by EPT, EPT will re-establish end-to-end connectivity of the BFL between the access points at its own costs and will arrange, if necessary, with the Operator the reactivation of its services.

In case of a fault on a DSS located within EPT's area of responsibility, caused by a third party, EPT will re-establish end-to-end connectivity of the DSS between

access points. All other aspects regarding the reestablishment of Operator's services have to be initiated and controlled by and under the sole Operator's responsibility.

In any such cases, EPT shall not be held liable to pay any compensation or indemnity to the Operator.

Schedule 7 - Ordering and Provisioning Procedure

7.1 Appointment handling

The following appointment handling procedure is valid for and applicable to the provision of LLU Services (including MPF, MPFNP and SLLS). For the provision of the LLU Services, timely and suitable coordination between EPT, the Operator and the Operator's concerned End-User is required in order to fulfil and achieve the installation of the LLU Services.

Each Operator shall take an active part in the EPT booking manager system. This Web based application enables the on-line reservation of available appointment dates for LLU Services. A complete up to date user documentation is available on the website of EPT.

EPT shall define with the Operator applicable time frames and time allocation rules while the time usually needed for installing the different types of LLU Services as well as EPT's available labour forces shall be taken into consideration in this respect, in accordance with the terms of the applicable SLA(s).

The Operator shall arrange an appointment directly with the concerned End-User for the provisioning of the LLU Services and shall comply for this purpose with the Operator's available appointment range as specified with EPT, in accordance with the terms of the applicable SLA(s).

Appointments can only be scheduled in accordance with the terms of the applicable SLA(s).

The Operator shall notify to EPT the details of the appointment agreed upon with the End-User and specify notably the agreed date and time at which EPT's staff shall access to End-User's premises. Appointments must be notified by the Operator to EPT at least three (3) working days before the scheduled appointment date. In case the Operator's End-Customer does not respect the fixed appointment more than 3 times for a given installation, the order will be closed. A new order can be placed by the Operator after clarification of the situation with his End-Customer.

In case an appointment validly notified to EPT cannot be respected, the defaulting Party will inform the other Party without undue delay and the Parties shall further agree upon the next step thereof.

The cancellation of an appointment on behalf of the Operator must be notified to EPT at the latest the previous day of the agreed appointment before 4 p.m. In case EPT receives the cancellation of an appointment later than the above mentioned timeframe, EPT will charge the full connection charge for that type of service as defined in Schedule 8 – Tariffs.

In any case, both Parties shall do their best efforts to respect the notified appointments.

7.2 Provisioning of tie cable

7.2.1 General

Orders shall relate to Operator's dedicated equipment, which consists in tie

cables and associated Operator's termination blocks.

All installations shall be done by EPT directly or by EPT's subcontractors, as appropriate.

Forecasts and ordering shall be done by the Operator per Local Exchange and for each type of tie cable.

Forecasts and firm orders shall only be validly if made on the specific templates provided by EPT and properly completed.

In case of missing or incorrect data, the concerned Forecast or order shall be rejected and the reasons of such rejection will be specified in EPT's reply message.

All Forecasts and firm orders shall be submitted by registered mail to the EPT's SPOC for LLU Services.

Irrespective of the terms and conditions stated below, EPT reserves the right to reject any Forecasts for a given Local Exchange in case the volumes requested by the Operator for the concerned Local Exchange in the said Forecasts are not in line with reasonable market demands.

7.2.2 Ordering Procedure

The Operator can order tie cabling through a firm order, which shall define and detail precisely for all concerned Local Exchange(s) all the capacity(ies) requested per type of tie and specify the Ready for Service Date at which the Operator wants the said tie cabling to be ready. In any case, the effective Ready for Service Date of tie cabling shall not occur before T30 as from the firm order effective date. EPT shall confirm the receipt of every firm order and inform the Operator when the installation of the related tie cables and termination blocks is completed.

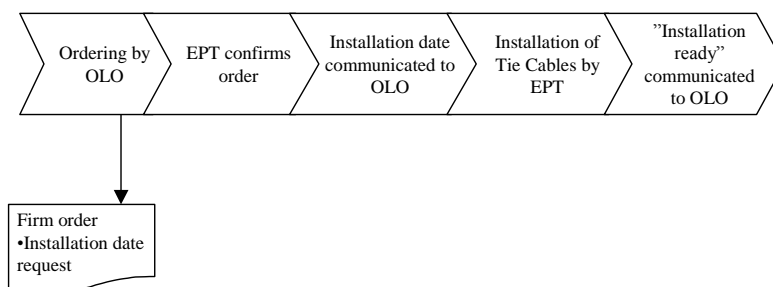

Figure 34: Overview of the ordering process of tie cables.

7.2.3 Term and billing

The minimum period of service for any tie cable (whether internal or external) shall be twelve (12) months as from its Ready for Service Date. If an Operator terminates service of a tie cable before the end of the said minimum period of service, the Operator shall pay to EPT a sum equal to twenty percent (20%) of

the rental charges applicable to such tie cable, being the rental charges applicable on the Ready for Service Date and calculated for the remaining period of its minimum term of service.

For each tie cable and associated products and services ordered by the Operator, the Operator shall pay to EPT monthly in advance the applicable connection and rental charges as specified in Schedule 8 – Tariffs.

7.2.4 **Internal tie cables**

Each order for internal tie cables to be passed by the Operator for a given Co-Location Equipment Room shall cover a minimum capacity of (i) one hundred (100) pairs for broadband services or (ii) one hundred (100) pairs for voice or narrow-band services, while the maximum capacity that may be ordered in one time shall be strictly limited to five hundred (500) pairs.

The Operator may order additional internal tie cable capacity when the net amount of available connections per internal tie cable type within a given Co-Location Equipment Room is equal or inferior to one hundred (100) pairs.

Subject to priory agreed Forecasts, EPT shall make reasonable endeavours to provide the ordered internal tie cables within T30 to the Operator. Tie cables can also be provided in relation to a new Co-Location Equipment Room project and shall in such case be part of the related overall planning and timing.

7.2.5 **External tie cables**

Each order for external tie cables to be passed by the Operator for a given Co-Location Equipment Room shall cover a minimum capacity of one hundred (100) pairs, while the maximum capacity that can be ordered in one time is limited to five hundred (500) pairs.

The Operator may order additional external tie cable capacity when the net amount of available connections per internal tie cable type within a given Co-Location Equipment Room is equal or inferior to one hundred (100) pairs.

Subject to priory agreed Forecasts, EPT shall make reasonable endeavours to provide the ordered external tie cables within T31 to the Operator.

7.3 **Provisioning procedure of Metallic Path Facility**

7.3.1 **Metallic Path Facility without Number Porting (MPF)**

7.3.1.1 **Definition**

The ordering procedure for MPF without migration of service covers the following tiered inter-Party activities:

- The Operator's submission of a MPF feasibility survey request and EPT's reply to that request either in a positive or in a negative way,
- In case of a positive survey, the Operator can order the provisioning of the MPF by specifying an appointment for that specific MPF on the on-line booking manager system, while EPT shall confirm the date on which the MPF line will be activated by sending a time schedule message.

7.3.1.2 General considerations

EPT shall not accept any order for MPF unless the following prerequisites have been fulfilled:

- An individual LLU Agreement has been signed between the Parties,
- A Co-Location Equipment Room on the concerned MDF Site exists and the installation of an internal or external tie cable has been completed.

The MPF ordering process is Operator-controlled.

This means that:

- End-Users shall contact directly the Operator they wish to purchase telecommunications services from,
- Before signature of an order for MPF, the Operator shall fully and precisely inform the End-User about the procedures and responsibilities in case of providing service to the End-User through MPF service and about the related impacts on his/her existing telecommunications services,
- EPT shall not accept any orders for MPF issued directly by an End-User,
- Only the Operator shall communicate with EPT,
- Submission of MPF survey request shall only be accepted if made by automatic file transfer via Web service in SOAP format.

In case of doubt or of any claim raised by the End-User or by an Operator impacted thereby, the new Operator contracting service with the End-User shall provide upon first request and within T4 due evidence of the End-User's valid consent by submitting the original request-form signed by the End-User. Such documents shall be kept and archived by the Operator at least for the period specified by applicable Luxembourg law for contractual documents.

An Operator can submit a survey request for provisioning of MPF in those local area networks where this Operator has contracted internal or external Co-Location Equipment Room(s). To determine the relation between the End-User address to his/her serving Co-Location Equipment Room or the relevant SLCP, the Operator can refer to the EPT's Internet database dedicated to such inquiries.

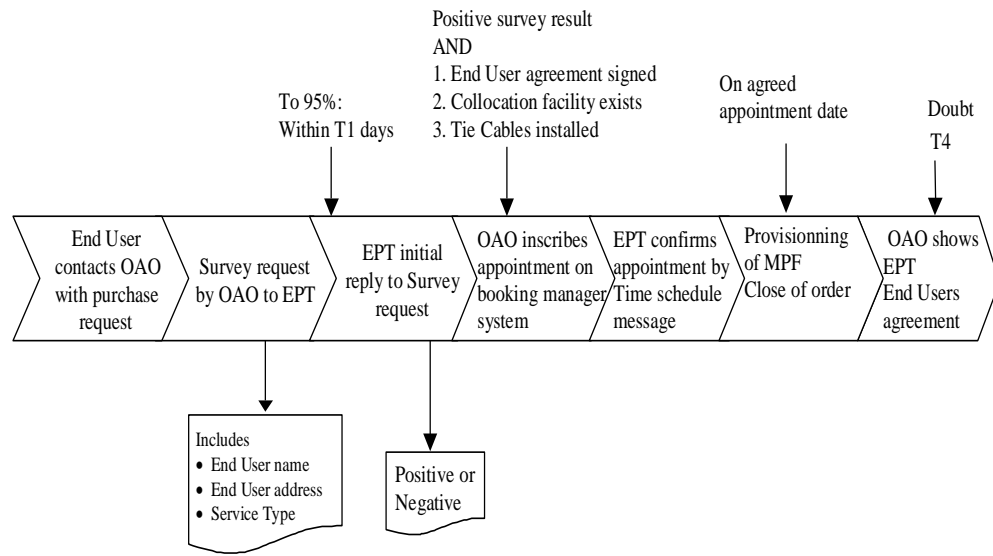

Figure 45: Ordering process for MPF.

7.3.1.3 Submission of an MPF survey request

The Operator shall submit an MPF_Survey Request of the provision type “New Line” to EPT

A submitted MPF survey request shall contain at least the following information:

- Operator’s Reference Number,
- Full End-User's name,
- End-User's exact installation address, including relevant floor and flat number indications
- MDF number,
- Provision Type: “New Line”,
- Service Type requested (narrow band or broadband).

EPT will respond to such survey request within the timescale defined in Schedule 9 Parameters by sending back either (i) a negative survey answer indicating the relevant reasons thereof, or (ii) a positive answer with the relevant technical information on the MPF.

The following reasons will nevertheless lead to a negative survey answer:

- End-User's address is not connected to EPT’s local network,
- Address is not served by the indicated MDF or SLCP,
- MPF is not available for the requested service quality,
- Unallocated MPF is not available to the End-User's address,
- Unallocated MPF is not available in intermediate sections in the local area network,
- Unallocated tie cable capacity is not available,
- Allocation of MPF for broadband is inhibited due to interference problems on that section of the network,
- Allocation of MPF for broadband is inhibited due to cable length greater than 6000 m on that section of the network,

A complete up to date list of the reasons leading to a negative survey is published on the website of EPT, including the order of the analysis of the parameters of the survey.

EPT will endeavour to reply to ninety-five percent (95%) of the received survey requests within T1.

In case the key conditions of MPF submission are met and essential information has been provided, EPT will handle all received valid survey requests in a non-discriminatory way based on the “first in - first served” principle and in the same manner it handles its own internal requests for MPF.

While performing a survey for MPF, EPT will reserve the involved elements of EPT Infrastructure for a period of T2, as defined in Schedule 9 Parameters.

If in the meantime no appointment date for the line activation has been received from the Operator for provisioning the allocated MPF, the MPF survey shall be cancelled and the reservation of the allocated EPT Infrastructure elements, as set forth here above, be automatically levied.

In case the survey performed by EPT results in:

- a positive answer to a survey for MPF services, EPT will provide to the Operator the cable length information of the reserved MPF as well as the EPT's reference number in case of survey success; or
- a negative answer, no other action is taken by EPT as far as the EPT's search engine showed a spare copper route for a specific address. However, in case the search engine indicated that no copper route is available, EPT shall charge the amount applicable to the negative survey as specified in Schedule 8 – Tariffs
- a positive answer and if the Operator does not place a MPF provisioning order in due time, EPT shall charge the amount applicable to the survey as specified in Schedule 8 - Tariffs.

The Operator shall not pay the survey charge in case of a positive answer followed by a firm provisioning order issued by the Operator and specifying an appointment date for the line.

7.3.1.4 Order for Provisioning of MPF

After notification of a positive survey, the Operator shall coordinate forthwith an appointment date with the concerned End-User and formally reserves one of the free availabilities on the EPT's on-line booking manager system. After proper reservation of the appointment date, the concerned time slot shall no longer be available for other Operators. EPT shall validate the appointment and confirm the activation date by sending a XML message "MPF Time Schedule" to the Operator.

The number of appointments available per calendar week for each Operator shall be periodically negotiated between EPT and the concerned Operator.

A maximum delay of three (3) months between the current date and the appointment date is allowed.

At the confirmed activation date, EPT will connect the MPF in the network and test the line from the MDF to the NTP at the End-User's premises.

In case of positive testing, the end point of the MPF on the MDF will be the jumper to the indicated connection point of the Operator's tie cable.

The Operator shall be responsible for all the services deployed on this line as from the activation date onwards.

Should the requested MPF installation fail for any of the below reasons, EPT shall inform the Operator by the electronic messaging system:

- Failure to meet the relevant test,
- Defect copper pair in a section,
- Discrepancy between data for reserved MPF and physical availability of pairs in the network,

- Damaged cable within a section of the path for that MPF.

EPT will endeavour to find an alternative solution to provide the MPF as ordered by the Operator in a T6 time period. If reasonable means do not allow the MPF provisioning to the Operator, EPT shall send a final failure message to the Operator.

A final failure message shall also be sent in case of any of the following reasons:

- No availability of alternative solution to initially reserved MPF routing,
- Incoherence in the allocation of tie cable connection points,
- Mismatch between MPF type and indicated connected equipment type,
- Mismatch between MPF survey request and MPF provisioning order.

7.3.1.5 Connection of the in-house cabling at the End-User premises

EPT's MPF responsibility terminates at the NTP as described in Schedule 1 – Service Description – Metallic Path Facility.

In case the Operator wants to connect additional in-house cabling to EPT's NTP, it is entitled to connect the cables to distribution boxes of single-family houses or to the cross-connection distribution frame of corporate customers.

In case additional in-house cabling is to be connected to an NTP in a multi-tenant premise, the Operator shall specify it in its order for MPF provisioning. At the moment of MPF installation, EPT will introduce the cable in the NTP-box.

If the Operator or the End-User wants to deviate from the above-mentioned standard, this shall also be expressly indicated in the order for MPF provisioning. A non-standard connection will normally need a modification at the NTP level and a specific survey will be required. In this case, normal timing as defined for the MPF provisioning shall not apply.

7.3.2 MPF combined with Number Porting (MPFNP)

7.3.2.1 Definition

This process allows the Operator to take over an active PSTN or ISDN basic access line together with the main number and multiple subscriber numbers (MSN) allocated to this line. Considering the complexity of combined provisioning, this procedure is limited to the above-mentioned types of service.

A combined MPFNP service can be ordered in two different manners, either as "swap express" or as "swap classic". The search engine "phone search" published on EPT's Website for Operator services allows to check for each phone number if a MPFNP service can be provided as "swap express" or as "swap classic":

1. MPFNP can be handled as provision type "swap express", if the existing active line is routed entirely on copper from the network termination point

(NTP) on the customer site to the main distribution frame (MDF) on the office site. In this case the swap of the line needs only works on the MDF, no works in the field have to be done.

- After the Operators submission of a survey request for the provision type “swap express”, EPT will reply to that request in a positive or negative way
 - In case of a positive survey, the swap of the line will be executed by EPT in a time frame between working day D+3 and D+7 after the positive survey response “survey success” to the Operator without any further action to be done by the Operator. No appointment has to be reserved through the online booking manager for this provision type.
 - EPT will confirm the activation of the MPFNP service by sending an XML message “MPFNP Activated” to the Operator
2. MPFNP will be handled as provision type “swap classic”, if the existing active line is not an end to end copper circuit. In this case the routing of the line has to be modified requiring works to be done by the EPT in the field.
- After the Operators submission of a survey request for the provision type “swap classic”, EPT will reply to that request in a positive or negative way
 - In case of a positive survey, the Operator shall coordinate an appointment date with the concerned End-User, and specify this appointment on the on-line booking manager system
 - EPT will confirm the activation date by sending an XML message “MPFNP Time Schedule” to the Operator. At the confirmed activation date the swap of the line will be executed by EPT
 - EPT will confirm the activation of the MPFNP service by sending an XML message “MPFNP Activated” to the Operator

If PSTN or ISDN Basic Access (BA) service is provided through an active system (concentrator or pair gain system) in the Local Loop, combined provisioning of MPF and NP is not possible.

7.3.2.2 General considerations

EPT shall not accept any order for MPFNP unless the following prerequisites have been fulfilled:

- A LLU Agreement has been signed by the Parties.
- An individual agreement for telephony service interconnection and number portability has been signed by the concerned Operator.
- A Co-Location Equipment Room on the concerned MDF Site exists and the installation of an internal or external tie cable has been completed.

The MPFNP ordering process is Operator-controlled.

This means that:

- End-Users shall directly contact the Operator they wish to purchase telecommunications services from End-User's PSTN or ISDN-BA service from,
- EPT will not accept any orders for MPFNP issued directly from an End-User,
- Only the Operator shall communicate with EPT,
- The contract(s) relating to currently provided End-User services by an Operator shall be terminated in compliance with the terms and conditions applicable to the said telecommunication services.
- The Operator has to assure that all prerequisites and required formalities in relation to the "Procedure for number portability" as defined by the "Number Portability" working group in May 2000 are respected.

In case of doubt or of any claim raised by the End-User or by an Operator impacted thereby, the new Operator contracting service with the End-User shall provide upon first request and within T4 due evidence of the End-User's valid consent by submitting the original request-form signed by the End-User. Such documents shall be kept and archived by the Operator at least for the period specified by applicable Luxembourg law for contractual documents.

An Operator can submit a survey request for provisioning of MPF in those local area networks where this Operator has contracted internal or external Co-Location Equipment Room(s). To determine the relation between the End-User address and its serving Co-Location Equipment Room or the relevant SLCP, the Operator can refer to the EPT's Internet database dedicated to such inquiries.

Orders for MPFNP survey request can only be submitted by exchanging XML messages via Web service in SOAP format.

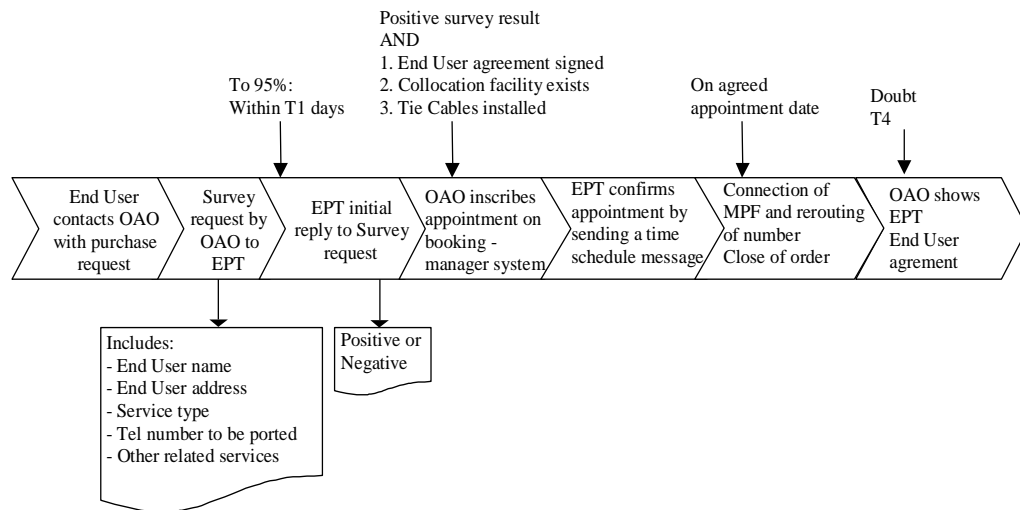

Figure 56: Order process for MPFNP.

7.3.2.3 Submission of an MPFNP survey request

A submitted MPFNP survey request shall contain at least the following information:

- Operator's Reference Number,
- End-User's name,
- End-User's exact installation address, including precise information about the relevant floor and flat number,
- End-User's EPT account number (required for automated process), (this number is to be asked for to the end user by the Operator, and the end user has the easy possibility to obtain this number by following the procedure mentioned in schedule 13 of this RUO)
- MDF number,
- Provision Type, "swap express" or "swap classic"
- Service Type Requested (Narrowband, Broadband),
- Service to be migrated (ISDN BA or PSTN) and if related services are active on that number or line,
- End-User's telephone number(s) to be ported,
- Line Detail (Multi-line without secondary number).

EPT will respond to this survey request within T1 as defined in Schedule 9 - Parameter by sending back either a negative or a positive survey answer, the latter including relevant technical information on the concerned MPF. If the key conditions of MPFNP delivery are met and essential information has been provided, EPT shall not reject a request.

A complete up to date list of the reasons leading to a negative survey is published on the website of EPT, including the order of the analysis of the parameters of the survey.

In case of a negative survey answer, EPT shall indicate the relevant reasons thereof, it being specified that the following reasons shall lead to a negative survey answer:

- Presently used MPF is provided through a pair gains system,
- Address is not served by the indicated MDF,
- Unallocated tie cable capacity is not available,
- Allocation of MPFNP for broadband is inhibited due to cable length greater than 6000m on that section of the network,
- Any of the reject reasons as specified in the number portability document from May 2000 as defined by the working group.
- In case the survey performed by EPT results in a negative answer, no other action is taken by EPT as far as the EPT's search engine showed a spare copper route for a specific address. However, in case the search engine indicated that no copper route is available, EPT shall charge the amount applicable to the negative survey as specified in Schedule 8 – Tariffs

In case the survey performed by EPT results in a positive answer and the

Operator does not place a combined provisioning order, EPT will charge the amount for the survey as indicated in the price schedule.

The Operator shall not pay the survey charge in case of a positive answer followed by a firm provisioning order issued by the Operator.

7.3.2.4 Order for provisioning of MPFNP

After notification of a positive survey, the Operator shall, in case of an MPFNP service ordered with the provision type "swap classic", coordinate an appointment date with the concerned End-User and formally reserve one of the free availabilities on the EPT's on-line booking manager system. After proper reservation of the appointment date, the concerned time slot shall no longer be available for other Operators. EPT shall validate the appointment and confirm the activation date by sending a XML message "MPF Time Schedule" to the Operator.

In case of an MPFNP service ordered with the provision type "swap express" the Operator does not need to fix an appointment with the concerned End User. The activation of the MPFNP service will automatically be executed in a time frame of working day D+3 and D+7 after the confirmation of the positive survey by EPT. The actual activation of the MPFNP service will be confirmed to the Operator by sending an XML message "MPFNP activated"

The migration shall be achieved in the following way:

- Connection by EPT of the MPF to the indicated connection point of the Operator's tie cable,
- Activation by EPT of the number re-routing in EPT's network to transfer calls to the Operator's network,
- Testing by the Operator of the successful service migration and confirmation of the successful migration by the Operator to EPT,
- As from the activation of the successful migration onwards, the Operator shall be responsible for all services deployed on the concerned line,
- In case migration of service has not been performed successfully, EPT will re-establish the initial situation and both Parties shall then liaise to identify the underlying problem,
- In case of successful migration, the Operator will inform the other Operators that the number porting has taken place in compliance with the procedure for number portability.

Should the migration of the related service not be achievable within the fixed time frame(s) as the End-User's line is damaged or not active at the time the said migration should have taken place, EPT shall inform the Operator thereof also by email and endeavour to propose a new migration date, as soon as the re-establishment of the MPF will allow it.

EPT shall nevertheless send a final failure message in case of any of the following situations:

- Incoherence in the allocation information of tie cable connection points provided by the Operator,
- Planned physical change in EPT's local network,
- Mismatch between MPFNP survey request and MPFNP provisioning order.

Once rejected, a request shall be closed in the database with the indication of the appropriate reject reason code(s). The combined order for provisioning of MPF and number porting shall be abandoned at this closing time and appropriate information shall be sent back to the Operator.

7.3.3 Transfer of MPF

7.3.3.1 Generalities

An active PSTN or ISDN basic access line provided through LLU Services, can be subject to subsequent transfer together with the main number and Multiple Subscriber Numbers (MSN) allocated to this line from a donor Operator to a receiver Operator, while the receiver Operator may be EPT.

The receiver Operator can cancel the service of a donor Operator provided the End-User has prior requested such cancellation by formally signing the necessary authorisation form and confirming expressly that it has complied with all its contractual obligations vis-à-vis the donor Operator.

7.3.3.2 Transfer of MPFNP from a donor Operator to a receiver Operator

For transfer of an active MPF combined with number porting, the standard procedure for number porting as defined by the working group in the document of May 2000, shall be complied with between the donor and the receiver Operators

In this respect, the receiver Operator shall submit a survey request to EPT, which shall handle such request in line with this Schedule 7 - Ordering and Provisioning Procedure.

The subsequent combined order for MPF transfer and number porting shall be handled in the following way:

- Migration shall be done by EPT at the date and time validated on the EPT's on-line booking manager system,
- Disconnection of the concerned MPF from the previous tie cable of the donor Operator and its connection to the indicated connection point of the receiver Operator's tie cable, all this by EPT,
- Information by EPT to the receiver Operator (per phone or email) of the migration achievement and of the number rerouting activation,
- Testing by the receiver Operator of the successful service migration and confirmation thereof to EPT,
- As from the moment of successful migration activation onwards, the receiver Operator shall be responsible for all services deployed on this line.

In case service migration has not been performed successfully, EPT shall proceed to validate the MPF transfer between tie cables. In case no abnormal situation can be stated at this level, EPT will re-establish the initial situation while

the donor and receiver Operators shall liaise without undue delay to identify the underlying problem,

In case of successful migration, the receiver Operator shall inform the other Operators that the number porting has taken place in compliance with the above-mentioned procedure for number portability.

In case of unsuccessful transfer, EPT shall update its database accordingly and send a closing message back to the receiver Operator per e-mail.

7.3.3.3 Transfer of MPFNP from Operator to EPT

In case the receiver Operator is EPT, the following rules shall apply in addition to the provisions set forth in Article 7.3.3.2 above.

In case of a transfer of an active MPF together with number porting back to EPT, where the number to be ported is belonging to a number range allocated to EPT, EPT shall inform the donor Operator at least three (3) working days before the effective transfer date by sending it an XML message "MPFNP CANCELTATION".

In case of a transfer of an active MPF back to EPT together with a number belonging to another Operator's numbering range, EPT shall previously issue a number porting request according to the above-mentioned number porting procedure to the donor Operator with the indication that MPF is transferred at the same time.

On the indicated activation date, EPT shall proceed as follows:

- Disconnection of the concerned MPF from the previous tie cable of the donor Operator and its connection to EPT's service line card, all this by EPT,
- Information by EPT to the receiver Operator (per phone or email) of the migration achievement and that the number rerouting can be activated,
- Testing by EPT of the successful service migration,
- As from the moment of successful migration activation onwards, EPT shall be responsible for all services deployed on this line.

In case service migration has not been performed successfully, EPT shall proceed to validate the MPF transfer between tie cables. In case no abnormal situation can be stated at this level, EPT will re-establish the initial situation and shall liaise without undue delay with the donor Operator to identify the underlying problem.

In case of successful migration, both EPT and the donor Operator shall update forthwith their databases and close the relating request, while EPT shall send a broadcast message to the other Operators and to ILR in compliance with the above-mentioned number porting procedure.

In case of an unsuccessful transfer, the donor Operator shall close the request, while both Parties shall update forthwith their respective databases and further liaise without undue delay to identify the underlying problem.

7.3.4 Hand-back Procedure

In case an End-User terminates its services provided by the Operator through MPF, this Operator shall inform EPT in accordance within the procedures and

principles defined in point 4 “property rights” that the MPF has become available for reallocation.

The Operator shall send this hand-back information by an electronic message.

To avoid any undue disconnections, the hand-back message shall contain at least the following mandatory information:

- Operator's Cancellation Reference,
- Old Operator's Reference,
- Old EPT's Reference,
- Type of hand-back (MPF or MPFNP),
- Tie-cable connection point number,
- Full End-User's name,
- End-User's address,
- Disconnection Due Date.

EPT shall confirm the hand-back message by a XML message "MPFNP CANCELTATION" sent to the Operator within T9.

This allows the Operator to re-use the “Tie-Cable Connection point number” from that time onwards (without any further delay managed by EPT).

At the date EPT receives all relevant and correct hand-back information, the rental billed to the Operator for this line shall be terminated. The applicable termination fee shall be charged on the last rental bill.

In case of incoherence of the submitted mandatory hand-back information after validation in the EPT's database, this stated incoherence will be indicated in a reply message to the Operator.

The MPF shall not be disconnected until the incoherence has been duly clarified with both Parties' best endeavours. The rental of the MPF billed to the Operator shall continue until the MPF can finally be effectively disconnected.

7.3.5 **Re-activation of a ceased MPF**

If an End-User terminates the telecommunication service(s) provided by the Operator by means of the MPF, the Operator shall submit hand-back information according to Schedule 7, chapter 7.3.4. In this case, the line will be temporary put out of operation by EPT on MDF level. The routing through EPT's access network shall not be changed until this route or part of this route is required to deliver another circuit ordered by an Operator or used by EPT on a first-come-first-served basis.

In case the same Operator, the End-User of which terminated the telecommunication service(s) on the above-mentioned line, orders within a period

of maximum ninety (90) days following the hand-back information the re-installation of that specific ceased MPF, a special order “re-activation of a ceased line “shall be sent to EPT by XML message via Web service in SOAP format, as defined in the description “Procédures d’échange de messages entre l’EPT et les OAO pour le dégroupage (MPF) et la portabilité (NP)” published on the EPT’s Web site.

In case the route or part of the route in the access network has not been required in the meantime to complete another circuit ordered by an Operator or used by EPT, EPT will handle the re-activation within a time frame of D+3 and D+7 business days after the day on which the positive response has been sent by EPT. No fixed appointment via the booking manager system is needed by the Operator.

In case the route or part of the route of a specific ceased circuit has been required to fulfil another order of an Operator or a need of EPT, when receiving the “re-activation” order, EPT will inform the Operator by XML message that the re-activation will be handled through the same process as for a new non-active line, i.e. the Operator has to fix an appointment via the booking manager system.

In both cases a possible supplementary number portability process (e.g. the number has to be migrated from a donor Operator to a receiving Operator) should be handled separately according the normal “NP Request” procedure.

The tariff applicable to the re-activation of an MPF is defined in Schedule 8 of the RUO. This tariff is independent of the work to be done in the access network.

7.3.6 **Cancellation of an order before activation**

If an Operator wants to abandon its request for MPF after submission of a formal order by the electronic messaging system, it shall send a cessation order by e-mail to EPT, which shall specify at least the following information:

- MPF number,
- Tie cable connection point number,
- Full End-User's name,
- End-User's address.

If the date of receipt of the order cancellation by EPT is more than T5 ahead to the agreed appointment date with the End-User, EPT will cancel the order and the Operator shall pay the MPF charge for order cancellation before activation as

well as the related survey charge, as defined in Schedule 8 – Tariffs.

In case EPT receives the cessation order less than T5 before the agreed appointment date with the End-User or in case of MPFNP order, EPT will cancel the order and charge the full connection charge for that type of service as defined in Schedule 8 – Tariffs, while the survey charge shall not be due.

EPT will send a confirmation message back to the Operator within T9.

7.4 Provisioning Procedure of Shared Local Loop Services (SLLS)

7.4.1 Splitters and Filters

7.4.1.1 Generalities

In order to provide SLLS, splitters have to be installed at EPT's Local Exchanges.

At End-User's premises, splitters or filters are needed, depending on the configuration as explained in Schedule 3 – Service Description – Shared local loop Service (SLLS).

Splitters and filters are provided by EPT upon Operator's request as set forth below.

7.4.1.2 Forecasting

In case the Operator is willing to benefit from SLLS, it shall timely provide four (4) times a year a rolling Forecast for the related expected need of splitters and filters, while such Forecasts for splitters shall differentiate between POTS and ISDN splitters, for EPT's Local Exchanges or End-User's premises. Based on such Forecasts, EPT will set-up framework contract(s) with one or several equipment supplier(s).

The numbers of splitters and filters specified in any Forecast shall be coherent with the SLLS Forecast. As the splitters have to be installed in fixed multiples per type in the different Local Exchanges, certain excess thereof having regards to the SLLS number has to be considered.

7.4.1.3 Ordering and Provisioning

7.4.1.3.1 Generalities

The Operator can order splitters for its used SLLS through a firm order, which shall be issued on the specific templates and instructions provided by EPT.

For each Operator's firm order for splitters/filters, EPT shall send a corresponding delivery request to its equipment supplier. EPT shall inform the Operator of the delivery time confirmed by the supplier as well as of any unforeseen delay impacting the said delivery.

EPT will provide splitters for POTS SLLS or ISDN SLLS according to ITU recommendation G922.1.

7.4.1.3.2 Splitters for Local Exchange

The order shall specify the requested number of incremental units, per type of unit and this for each individual Local Exchange.

The splitters for EPT's Local Exchange area shall be provided and installed under EPT's responsibility. For each installation of a block of CO splitters, a dedicated tie cable will be installed between the splitters and the Operator's HDF.

The conditions applicable to the installation of a tie cable as defined in Schedule 4 – Service Description –tie cables shall apply, while these tie cables shall be ordered in due time by the Operator.

7.4.1.3.3 Splitters for End-User's site

Splitters for End-User's site can be ordered by the Operator in increments of fifty (50), and shall be installed by the Operator.

The order shall specify the requested number of incremental units, per type of unit.

7.4.1.3.4 Filters for End-User's site

Filters can be ordered by the Operator in increments of fifty (50), and shall be installed by the Operator.

The order shall specify the requested number of incremental units, per type of unit.

7.4.2 Shared Local Loop Services (SLLS)

7.4.2.1 General considerations:

The following process allows the Operator to order a SLLS and consists of a 3 tiered inter-Parties activity:

- The Operator's submission of a survey request and EPT's reply to this request in a positive or negative way,
- In case of a positive survey, the Operator shall coordinate an appointment date with its End-User directly and reserves one of the free availabilities on the EPT's on-line booking manager device.
- EPT shall confirm the activation date by sending a notification "SLLS Time Schedule" to the Operator and the modification of the lines to provide SLLS service will be achieved at the confirmed activation date.

EPT will not accept any order for SLLS unless following prerequisites have been fulfilled:

- A LLU Agreement has been signed between the Parties,
- A Co-Location Equipment Room at the concerned MDF Site exists and the installation of an appropriate internal or external tie cable has been duly completed.

The SLLS ordering process is Operator-controlled.

This means that:

- End-Users shall contact directly the Operator they wish to purchase the telecommunications services from,
- Before signature of an order requiring SLLS, the Operator shall inform the End-User about the procedures and responsibilities in case of providing service through SLLS, and about the related impacts on his/her existing telecommunications services,
- EPT shall not accept any orders for SLLS issued directly by an End-User,
- Only the Operator shall communicate with EPT.

In case of inconsistency, doubt or any claims raised by the End-User, the Operator contracting service with the End-User, shall provide upon first request and within T20 due evidence of the End-User's valid consent by submitting the original request-form signed by the End-User. Such documents shall be kept and archived by the Operator for at least the period specified by the applicable Luxembourg law for contractual documents.

Orders for SLLS survey request can be submitted by electronic messaging transfer of XML files via Web service in SOAP (Simple Object Access Protocol) format or via e-mail exchange.

The Operator shall conform to EPT's instructions and specifications applicable to electronic information exchange as described in Schedule 6 - Planning and Operation.

An Operator can submit a survey request for SLLS in those local area networks where this Operator has contracted internal or external Co-Location Equipment Room.

To determine the relation between the End-User's address to the serving Co-Location Equipment Room, the Operator can refer to the EPT's Internet database dedicated to such inquiries.

7.4.2.2 Submitting of a Shared Local Loop Service (SLLS) survey request

A SLLS survey request shall contain at least the following information:

- Operator's Code,
- The requested service type (SLLS),
- Full End-User's name,
- End-User's Address,
- End-User's EPT account number (required for automated process),
- Number of PSTN or ISDN line serving as SLLS support,
- Service Type requested (xDSL).

EPT shall respond to this survey by sending back either (i) a negative survey answer indicating the relevant reasons thereof, or (ii) a positive survey answer with the relevant technical information..

In case the key conditions of MPF submission are met and essential information has been provided, EPT will handle all received valid survey requests in a non-discriminatory way based on the "first in - first served" principle and in the same

manner it handles its own internal requests for SLLS.

The following reasons shall nevertheless lead to a negative survey answer:

- Failure of End-User's identification by EPT,
- Miss-match between End-User's name and End-User's address,
- Miss-match between End-User's name and the number of the PSTN or ISDN line serving as SLLS support,
- Absence of provision of PSTN or ISDN service through a MPF,
- SLLS allocation inhibition due to interference problems on that section of the network.

EPT will endeavour to reply to 95% of the survey requests within T11.

While performing a survey for SLLS, EPT will reserve the involved SLLS to the requesting Operator for a maximum period of T12 as defined in the Schedule 9 Parameters.

If in the meantime no appointment date has been received from the Operator for provisioning the allocated SLLS, the SLLS survey shall be cancelled and the reservation on the specific pair in the Local Loop shall be automatically levied.

In case the survey performed by EPT further to a request for SLLS results in:

- a positive answer, EPT will provide to the Operator the cable length information as well as the information whether this line is a PSTN or an ISDN line; or
- a negative answer or if the Operator does not place an appointment date in due time, EPT shall charge the amount for the survey as specified in the Schedule 8 - Tariffs.

The Operator shall not pay the survey charge in case of a positive answer followed by a firm provisioning order.

7.4.2.3 Order for Provisioning of SLLS

After notification of a positive survey, the Operator shall coordinate an appointment date with the concerned End-User for SLLS activation and formally reserve one of the free availabilities on the EPT's on-line booking manager system. After proper reservation of the activation date, the concerned time slot shall no longer be available for other Operators. To finally accept the activation date, EPT will send a XML message "SLLS Time Schedule" to the Operator.

At the confirmed activation date, EPT will connect the SLLS in the network and test the line from the MDF to the centralised splitter interface at the End-User's premises or at the NTP in case distributed filters are used.

In case of a positive testing, the end point of the splitter in the Local Exchange will be jumpered to the indicated connection point of the Operator's tie cable.

Within T14 after the SLLS activation, EPT shall send a confirmation with the electronic messaging system to the Operator.

As from the time of the above-mentioned jumpering onwards, the Operator shall be responsible for all services deployed on this line.

Should the requested SLLS installation fail for any of the following reasons, EPT shall inform the Operator by the electronic messaging system:

- If the installation of the splitters on the line did prevent the underlying POTS or ISDN service to continue to work properly (mainly due to insertion loss of the splitters), or
- In case of a discrepancy exists between the information for reserved SLLS and physical situation in the network preventing installation of SLLS (for instance, PSTN or ISDN service is provided through active elements in the network; pair gain, etc).

Such cases prevent the provisioning of SLLS on this specific line. If there exists no second POTS or ISDN line to the same End-User in the same premises that could support SLLS, the SLLS order has to be definitively closed and EPT shall send a final failure message to the Operator.

7.4.3 **Hand-back Procedure for SLLS**

In case an End-User terminates the telecommunications services provided by the Operator through SLLS, the Operator shall inform EPT of the availability for reallocation of the concerned SLLS within T18 by electronic message in the format defined in Schedule 6 - Planning and Operation.

To avoid any undue disconnection, the hand-back message shall contain at least the following mandatory information:

- SLLS number,
- Centralised Splitter or Distributed Filters,
- Tie-cable connection point number,
- Full End-User's name,
- End-User's Address,
- Date of deactivation.

EPT shall confirm the hand-back message receipt by a XML message "SLLS CANCELLATION" sent to the Operator within T19. At the date EPT receives all relevant and correct hand-back information, the rental billed to the Operator for this line shall be terminated. The termination fee shall be charged on the last rental bill.

In case of incoherence of the submitted mandatory hand-back information after validation in the EPT's database, this stated incoherence will be indicated in a reply message to the Operator.

The SLLS shall not be disconnected until the incoherence has been clarified with both Parties' best endeavours. The rental of the SLLS billed to the Operator shall continue until the SLLS can finally be effectively disconnected.

7.4.4 **Cancellation and reactivation of Low Bandwidth Service**

7.4.4.1 **Cancellation of low-band service**

A cancellation request for Low Bandwidth Service has to be sent by the concerned End-User directly to EPT.

In case an End-User cancels the Low Bandwidth Service, he/she has contracted with EPT, the SLLS shall automatically be converted into a MPF.

EPT shall inform the Operator of this conversion by the electronic messaging system and give the following information:

- SLLS number,
- Centralised splitter or distributed filters,
- Tie cable connection point number,
- Full End-User's name,
- End-User's address,
- New allocated MPF number,
- Date of conversion.

The Operator shall be billed with the MPF charge as indicated in Schedule 8 – Tariffs as from the date the Low Bandwidth Service will have been effectively cancelled.

7.4.4.2 Reactivation of low-band service

A line that had been used as SLLS and converted to an MPF after cancellation of the Low Bandwidth Service can be later on reactivated as a SLLS. This change back from MPF to SLLS shall take place upon the End-User's formal request for activation of Low Bandwidth Service to be provided by EPT.

If the End-User orders the Low Bandwidth Service from EPT, the MPF service shall automatically be converted into a SLLS.

EPT shall inform the Operator of this conversion by the electronic messaging system and give the following information:

- MPF number,
- Tie cable connection point number,
- Full End-User's name,
- End-User's address,
- New allocated SLLS number,
- Date of conversion.

The Operator will be billed the SLLS charge as indicated in Schedule 8 – Tariffs as from the date the Low Bandwidth Service will be activated.

7.4.5 Cancellation of an order before activation

If, upon the End-User's request to the Operator or for any other reason, the Operator wants to abandon its request for SLLS after having submitted a formal order, the Operator shall inform EPT by the electronic messaging system of its decision to cancel the said order. The cancellation message shall contain at least the following information:

- SLLS number,
- Tie cable connection point number,
- Full End-User's name,
- End-User's address.

If the receipt date by EPT of the End-User's cancellation order is:

- less than T21 before the agreed appointment date with the End-User, EPT will cancel the order and the Operator shall pay the SLLS charge for order cancellation before activation as well as the survey charge, as defined in Schedule 8 – Tariffs; or
- beyond T21 before the agreed appointment date with the End-User, EPT will cancel the order and charge the full SLLS provisioning tariff as defined in Schedule 8 – Tariffs to the Operator, while the survey charge shall not be due.

EPT will send a confirmation message back to the Operator within T19.

7.5 Provisioning Procedure of Backhaul services in the context of SLU

7.5.1 Backhaul Transmission Capacity (BTC)

7.5.1.1 Survey request

Before any Operator's ordering for BTC Services between a CO and a SLCP, the availability of spare capacity to the said SLCP has to be prior checked by EPT.

For this purpose, the Operator shall submit a survey request by e-mail to bo_coloc@ept.lu, such survey request having to contain at least the following information:

- Operator's name;
- Operator's contact point for this specific project including related e-mail address and telephone number;
- Concerned local network;
- Address of the SLCP;
- Exact location of the Operator's Cabinet/Equipment in the boundary of EPT's SLCP; and
- Requested delivery date.

EPT will endeavour to reply to ninety-five percent (95%) of the valid survey requests received within ten (10) working days.

In case of a positive answer, EPT will provide to the Operator the technical details of the proposed solution and the earliest possible delivery date.

7.5.1.2 Ordering

If at that time of an order for BTC no spare fibre link between EPT and the Operator at CO and/or SLCP level is available, the Operator shall place an order for the installation of appropriate fibre link(s).

The order for BTC Services has to be sent by the Operator to the following address: bo_coloc@ept.lu and shall contain at least the following information:

- Operator's name;
- Operator's contact point for this specific project including related e-mail address and telephone number;
- EPT reference of the answer to the survey request;
- Required RFS date,
- Fiber link to be used and/or to be provided at CO level, and
- Fiber link to be used and/or be provided at SLPC level.

EPT shall confirm the receipt of every firm order for BTC Services and inform the Operator when the concerned BTC Services are ready for service on EPT's side.

7.5.2 Access to ducts

7.5.2.1 Survey request

Before any Operator's ordering access to a duct between a CO and a SLCP, the availability of a spare duct to the concerned SLCP has to be prior checked by EPT.

For this purpose, the Operator shall submit a survey request by e-mail to the following address: bo_coloc@ept.lu such request having to contain at least the following information:

- Operator's name;
- Operator's contact point for this specific project, including related e-mail address and telephone number;
- Concerned local network;
- Address of the concerned SLCP;
- Exact location of the Operator's Cabinet / Equipment in the boundary of EPT's SLCP; and
- Requested delivery date.

EPT will endeavour to reply to ninety-five percent (95%) of the valid survey requests received within ten (10) working days.

In case of a positive answer, EPT will provide to the Operator a map showing the routing of the concerned duct as well as short description of the proposed solution and the earliest possible delivery date.

7.5.2.2 Ordering

Any Operator's ordering for an access to a duct has to be sent by the Operator to the following address: bo_coloc@ept.lu and shall contain at least the following information:

- Operator's name;
- Operator's contact point for this specific project, including related e-mail address and telephone number;
- EPT's reference of the answer to the concerned survey request; and
- A sketch showing the access points to EPT Infrastructure as required by the Operator.

EPT shall first confirm the receipt of every firm order for DSS and indicate EPT's target RFS date, and further inform the Operator when the duct is ready for service on EPT's side.

7.5.3 Backhaul Fibre Link Service

7.5.3.1 Survey request

Before any Operator's ordering a BFL Service between a CO and a SLCP, the availability of spare fibre capacity to the concerned SLCP has to be prior checked by EPT.

For this purpose, the Operator shall submit a survey request by e-mail to the following address: bo_coloc@ept.lu, such request having to contain at least the following information:

- Operator's name;
- Operator's contact point for this specific project, including related e-mail address and telephone number;
- Concerned local network;
- Address of the concerned SLCP;
- Exact location of the Operator's Cabinet / Equipment in the boundary of EPT's SLCP; and
- Requested delivery date.

EPT will endeavour to reply to ninety-five percent (95%) of the valid survey requests received within ten (10) working days.

In case of a positive answer, EPT will provide to the Operator a map showing the routing of the concerned duct as well as short description of the proposed solution and the earliest possible delivery date.

7.5.3.2 Ordering

Any Operator's ordering for a BFL Service has to be sent by the Operator to the following address: bo_coloc@ept.lu and shall contain at least the following information:

- Operator's name;
- Operator's contact point for this specific project, including related e-mail address and telephone number;
- EPT's reference of the answer to the concerned survey request; and
- A sketch showing Operator's available infrastructure between the specific RT and EPT's fibre infrastructure

EPT shall first confirm the receipt of every firm order for BFL Services and indicate EPT's target RFS date as well as further inform the Operator when the BFL is ready for service on EPT's side.

Schedule 8 – Tariffs (will be considered in an apart module) !!!

8.1 Internal tie cable

Item	Euro
Connection charge for tie cables - voice-band usage - per 100 pairs	1.279,91
Connection charge for tie cables - broadband usage - per 100 pairs	2.027,67
Monthly charge for tie cables voice-band usage - per 100 pairs	2,74
Monthly charge for tie cables broadband usage - per 100 pairs	2,74
EPT manpower for special works required by the Operator - per hour	See point 8.8 below

8.2 External tie cable

Item	Euro
Connection charge for tie cables - voice-band usage - per 100 pairs	Bespoke
Connection charge for tie cables - broadband usage - per 100 pairs	Bespoke
Monthly charge for tie cables voice-band usage - per 100 pairs	Bespoke
Monthly charge for tie cables broadband usage - per 100 pairs	Bespoke
EPT manpower for special works required by the Operator - per hour	See point 8.8 below

8.3 Metallic Path Facility (MPF)

(SAME CHARGES FOR MPF combined with NP)

Item	Euro
Survey charge for a non-active local loop including length provisioning in case of no firm order	26,84
Survey charge for an active local loop including length provisioning in case of no firm order	14,98
Connection charge MPF including survey charge - non-active local loop	95,81
Connection charge MPF including survey charge - active local loop	51,09
Costs for a rush order	250,00
Monthly rental MPF for voice-band usage	10,75
Monthly rental MPF for broadband usage	10,75
Monthly rental SLU	8,70
MPF Hand-back charge	17,33
Re-activation of a ceased MPF	18,78
MPF loop resistance measurement	157,00
MPF length, resistance, insertion loss measurement	157,00
MPF order cancelled before activation	7,41
MPF Wrongful Repair Request	161,59

EPT manpower for special works required by the Operator - per hour
--

See point 8.8 below

8.4 Shared Access

Item	Euro
Survey charge for an SLLS including length provisioning in case of no firm order	14,98
Connection charge SLLS including survey charge	70,00
Monthly rental SLLS	3,2
Provisioning of POTS/xDSL Splitters at the LE, 24 units	694,33
Provisioning of ISDN/xDSL Splitters at the LE, 24 units	950,78
Provisioning of a Splitter for End-User site	3,9
SLLS Hand-back charge	17,33
SLLS order cancelled before activation	7,41
SLLS Wrongful Repair Request	161,59
EPT manpower for special works required by the Operator - per hour	See point 8.8 below

8.5 Backhaul services in the context of SLU

8.5.1 Backhaul Transmission Capacity (BTC Services)

Item	Euro
Survey charge for a BTC Service to a dedicated SLCP	115,59
Connection charge for a fibre cable (xx fibres) between EPT's SLCP and the Operator Cabinet/Equipment	Bespoke
Connection charge for a fibre cable (xx fibres) between EPT's and the Operator at CO level	Bespoke
Activation charge for a BTC Service of 1GbE to a dedicated Operator Cabinet/Equipment	3000.-
Monthly rental for a BTC Service of 1GbE to a dedicated Operator Cabinet/Equipment (price per month)	336,00
EPT manpower for special works required by the Operator – per hour	See point 8.8 below

8.5.2 Duct Sharing Services (DSS)

Item	Euro
Survey charge for DSS to a dedicated SLCP	115,59
Connection charge for a DSS	Bespoke
Monthly rental for a DSS (30 mm inside diameter) per meter	0,49/meter/month
EPT manpower for special works required by the Operator - per hour	See point 8.8 below

8.5.3 Backhaul Fibre Link (BFL Services)

Item	Euro
Survey charge for a BFL Service to a dedicated SLCP	115,59
Connection charge for a fibre cable (xx fibres) between EPT's SLCP and the Operator Cabinet/Equipment	Bespoke

Connection charge for a fibre cable (xx fibres) between EPT's and the Operator at CO level	Bespoke
Activation charge for a BFL Service (2 fibres) to a dedicated Operator Cabinet/Equipment	1.525,69
Monthly rental for a BFL Service (2 fibres) to a dedicated Operator Cabinet/Equipment (price per month)	382,23
EPT manpower for special works required by the Operator – per hour	See point 8.8 below

8.6 Fault Repair – Standard SLA

8.6.1 The fault repair is achieved within T40.

<i>Time of intervention</i>	<i>Origin of the fault is situated</i>	<i>Price</i>
Business Hours	On EPT's side	For free
Business Hours	On Operator's side	Price A

8.6.2 The Operator wishes that the fault repair be done prior to another End-User's request or outside working hours. In this case, the following prices are applicable:

<i>Time of intervention</i>	<i>Origin of the fault is situated</i>	<i>Price</i>
Priority from 7am-7pm (Monday to Friday) and 8am-12pm (Saturday)	On Operator's or on EPT's side	Price B
From 7pm-7am from Monday to Friday, Saturday from 12am on and Sunday	On Operator's or on EPT's side	Price C

8.6.3 Manpower fees

- Price A = Actual EPT manpower fee - per hour plus surcharges following the table below
- Price B = Actual EPT manpower fee - per hour plus surcharges following the table below with a minimum of 250 Euros per intervention
- Price C = Actual EPT manpower fee - per hour plus surcharges following the table below with a minimum of 500 Euros per intervention.

For the avoidance of doubt, the prices A, B and C will not be charged by EPT to the Operator in case the concerned fault is due to a Force Majeure event or a more general failure concerning several End-Users.

<i>Time:</i>	<i>6h00-7h00</i>	<i>07h00-19h00</i>	<i>19h00-22h00</i>	<i>22h00-6h00</i>
Monday to Friday	50%	0%	50%	65%

Saturday	50%	65%
Sunday	70%	85%
Legal and public holiday	200%	215%

8.7 Fault Repair – Business SLA

8.7.1 EPT’s intervention is to be done within T41 for a LLU Service covered by a Business SLA (24/24h, 7/7d)

The conditions applicable to Business SLA as specified in Schedule 10 attached hereto shall apply.

<i>Time of intervention</i>	<i>Origin of the fault is situated</i>	<i>Price</i>
Priority during Business Hours	<i>On EPT’s side</i>	<i>For free</i>
	<i>On Operator’s side</i>	<i>Price B</i>
Outside Business Hours	<i>On EPT’s side</i>	<i>For free</i>
	<i>On Operator’s side</i>	<i>Price C</i>

8.7.2 Manpower fees

- Price A = Actual EPT manpower fee - per hour plus surcharges following the table below
- Price B = Actual EPT manpower fee - per hour plus surcharges following the table below with a minimum of 250 Euros per intervention
- Price C = Actual EPT manpower fee - per hour plus surcharges following the table below with a minimum of 500 Euros per intervention.

<i>Time:</i>	<i>6h00-7h00</i>	<i>07h00-19h00</i>	<i>19h00-22h00</i>	<i>22h00-6h00</i>
Monday to Friday	50%	0%	50%	65%
Saturday	50%			65%
Sunday	70%			85%
Legal and public holiday	200%			215%

For the avoidance of doubt, the prices A, B and C will not be charged by EPT to the Operator in case the concerned fault is due to a Force Majeure event or a more general failure concerning several End-Users.

8.8 Manpower fees

Euro

Actual EPT manpower fee - per hour	65,71
All manpower fees are based on the Luxembourg price index 702,29. They will be updated following the evolution of this price index.	

Schedule 9 - Parameter Schedule

9.1 Provisioning of MPF

Timer	Value	Description
T1	5 working days	Response time to the survey request
T2	20 working days	Maximum time period for MPF reservation as from the date the positive survey request has been send by electronic mail
T3	3 working days	Time period between the date the positive survey has been send by electronic mail and the date the Operator submits a firm activation order for the MPF
T4	5 working days	Delivering by Operator to EPT of the original MPF request form signed by the End-User in case of doubt
T5	2 working days	Order cancellation before agreed appointment date for installation of the service
T6	5 working days	Time period to submit an alternative solution in case the reserved resources in EPT's network are not usable to provide MPF
T8	2 working days	Time period as from the moment service has been terminated to inform EPT that MPF has become available for re-use
T9	2 working days	Confirmation by EPT to hand-back message or Cancellation of Order before activation time period to provide the hand-back message to EPT

9.2 Provisioning of SLLS

Timer	Value	Description
T12	10 working days	Maximum time period for SLLS reservation as from the date the positive survey request has been send by electronic mail
T13	3 working days	Time period between the date the positive survey has been send by electronic mail and the date the Operator submits a firm activation order for the SLLS
T18	2 working days	Time period as from the moment service has been terminated to inform EPT that SLLS has become available for re-use
T19	2 working days	Confirmation by EPT to hand-back message or Cancellation of Order before activation time period to provide the hand-back message to EPT
T20	5 working days	Delivering by Operator to EPT of the original SLLS request form signed by the End-User in case of doubt
T21	2 working days	Order cancellation before agreed appointment date for installation of the service

9.3 Provisioning of tie cables

Timer	Value	Description
T30	21 working days	Provision of ordered Internal tie cables
T31	35 working days	Provision of ordered Internal tie cables

9.4 Fault Reporting and Repair

Timer	Value	Description
T40	2 working day after the issuance day of a Fault Report	Time period to achieve 95% of fault repair requests.
T41	4,5 hours as from the Incident Ticket Opening	Time period to be complied with in case of Business SLA.

9.5 Other

Timer	Value	Description
T50	4 working days	Notification period for appointments sent to EPT
T51	5 working days	Provision of an internet address and password to the Operator to access the MDF information
T52	20 working days	Maximum period between the declaration of an Operator that it is interested in Local Loop Unbundling Services and the acceptance of first electronic exchanged file

Schedule 10 – Business SLA

10.1 Definitions related to the Business SLA

The following definitions apply to the SLA in relation to the LLU Services:

Business SLA Agreement

The specific agreement specifying all procedures, contact points, terms and conditions for LLU Services specifically covered by a Business SLA at the express Operator's option, to be entered into by and between the Parties in case the Operator wants to opt in for Business SLA, it being specified that:

- (i) a Business SLA agreement may only be entered into by the Parties provided the concerned Operator has prior entered into a LLU Agreement as specified in EPT's RUO in force
- (ii) in case the Parties already entered into a LLU Agreement prior to the entry into force of this RUO, the Business SLA Agreement that the Operator will further execute shall automatically amend the said LLU Agreement.

Intervention time

The intervention time is the duration calculated from the concerned Incident Ticket Opening to the Operator until EPT intervenes in order to repair the circuit.

Call-back Delay

The Call-back Delay is the duration calculated from the Incident Ticket opening until the first returned call or email by EPT to the Operator.

Penalty

The Penalty is a lump indemnification amount to be credited to the Operator upon written express request to EPT's relevant contact point for Business SLA as specified in the Business SLA Agreement.

10.2 Terms and conditions of the Business SLA

The Business SLA Agreement shall be provided for a minimum one (1) year lease period. After expiry of this 1st year, the Operator may terminate the Business SLA Agreement upon a one (1) month prior written notice.

In any case, the minimum duration for the LLU Services to be specifically covered by a Business SLA is one (1) month.

The applicable contact points and detailed procedures be complied with any Fault Report related to LLU Services covered by a Business SLA are specified in the Business SLA Agreement.

The intervention window is 24/24 hours and 7 days/7.

The applicable fees are as follows:

	Business SLA
SLA Business monthly lump sum fee covering up to 100 circuits in addition to the monthly fee for each LLU Services concerned	1000 EUR
Business SLA - activation fee per 1 LLU Service	9 EUR
Business SLA - Monthly rental fee per 1 LLU Service in addition to (i) the monthly fee as from the first circuit concerned and (ii) the monthly fee applicable for the concerned LLU Service.	9 EUR

For the avoidance of doubt, the terms and conditions of a Business SLA shall only apply provided the Fault Report in relation to a fault concerning LLU Services covered by a Business SLA:

- (i) contains all required minimum information as applicable to the type of LLU Service(s) concerned,
- (ii) expressly specifies the term “SLA” in the subject line of the Fault Report email,
- (iii) expressly specifies the reference number of the concerned Business SLA, and
- (iv) has been submitted to EPT’s contact point as specified in the Business SLA Agreement.

Fault clearance under Business SLA conditions will be free of charge for the Operator independent on the Intervention Time, provided the fault reported in the Fault Report duly lies within the section of the LLU Service for which EPT is responsible. In case the fault lies outside the section of the LLU Service for which EPT is responsible, the tariffs as specified in Schedule 8 – Tariffs (point 8.7) will be charged to the Operator.

Any fault validly reported by the Operator shall be deemed as duly cleared if the Operator fails to reject the related Incident Ticket Closing submitted by EPT within one (1) hour after receipt thereof.

10.3 Business SLA fault reporting and repair

Faults regarding LLU Services covered by a Business SLA have to be reported to a special FCP and in compliance with the procedures defined in the Business SLA Agreement.

Both Parties recognize and acknowledge that the Intervention Time shall commence when EPT issue the Incident Ticket Opening relating to the validly received Fault Report.

10.4 Business SLA characteristics

	Business SLA
Intervention Time	4,5 hours
Call-back Delay	0,5 hour

10.5 Penalties

In case EPT does not conform to a given Business SLA and provided the conditions applicable thereto as set forth in the applicable RUO have been duly complied with, a Penalty shall be paid by EPT, upon Operator's written express valid request, per concerned LLU Services covered by a Business SLA on the following basis:

Intervention Time (I)	Penalty
$I \leq 4,5h$	0
$4,5h < I \leq 8h$	40 EUR
$8h < I$	80 EUR

Schedule 11 – Rush Orders

1. An Operator may ask a rush order for unbundling services (MPF new line or MPFNP swap) under the condition that the Operator has first submitted a valid survey request for this line to EPT and that EPT has positively replied to this request. EPT's shall reply to the Operator's survey request within one (1) working day for requests received through the XML/SOAP procedure.
2. After reception of a XML/SOAP message "survey success" the Operator should reply to EPT by sending a "rush order" as defined in the description "Procédures d'échange de messages entre l'EPT et les Opérateurs pour le dégroupage (MPF) et la portabilité (NP)" published on the EPT/Telecom/Operators web site. Every Operator has the right to submit up to three (3) rush orders per month to EPT.
3. A valid rush order should be executed by EPT in a time frame of S +8 Wh and S+24 Wh, whereat "S" is the date and time of the reception by EPT of a rush order submitted by an Operator and "Wh" are the working hours which should be counted from Monday to Friday between 8h to 12h and 13h to 17h.
4. The Operator may propose an appointment within the before mentioned time frame which EPT should respect under the condition that EPT labor force is available at the proposed time. If that is not the case, EPT will fix another appointment within the same timeframe.
5. EPT will reply to the Operator's rush order request within a timeframe of "S+4 Wh". The message will contain the definitively retained date and time of the rush order appointment.
6. Rush order installations will only be executed during normal working hours, that is from Monday to Friday between 8h to 12h and 13h to 17h.
7. The Operator has to assure that the end-customer is informed of the exact date and time of the rush order installation, that access to the network termination point (NTP) is guaranteed and that the internal cabling at the customer premises is ready. If the installation can not be executed by EPT staff, for reasons beyond EPT's control (e.g. end-user's absence, no access to the NTP, internal cabling not ready) despite the appointment fixed with the end-user, the rush order will be stopped and EPT will duly report the stop of the rush order the Operator. The order should in this case be executed as normal unbundling order after the Operator has fixed a new appointment on a free available time slot on the booking manager. The costs of the rush order will be charged to the Operator as defined in Schedule 8 – Tariffs.
8. In case of serious doubt, the Operator may request of proof of the effective need of the rush order stop, and EPT has to respond to that request in a delay of one (1) working day.
9. All rush order installations will be charged to the Operator as defined in Schedule 8 - Tariffs

Schedule 12 – How to transmit the “Demande de raccordement souterrain” to the EPT by the Operator, on behalf of the End-User

12.1 Request

A standard form “Demande de raccordement souterrain” is available at EPT’s Web site or at the Operator’s simple request.

The Operator signs on behalf of the End-User a duly completed form and transmits it to EPT, provided that the Operator has been effectively mandated by the End-User in this respect. The Operator will explicitly indicate in the proxy document to be signed by the End-User that charges will be due for the realisation of the “raccordement souterrain”.

The Operator is not obliged to provide automatically EPT with a written proof of the mandate when transmitting a signed and completed “Demande de raccordement souterrain”. However, the Operator will provide EPT with a written proof at EPT’s simple request.

12.2 Invoicing

Within a delay of five working days (5) days after the day of receipt of the “Demande de raccordement souterrain”, the End-User on behalf of whom the Operator has transmitted to EPT the request, will receive a letter from EPT indicating the charges for realising the “raccordement souterrain” according to its price list in force.

12.3 End-User contact for the realisation of the “raccordement souterrain”

Within a delay of fifteen (15) days after the day of receipt of the “Demande de raccordement souterrain”, the “Projections” Service within EPT’s Fixed Infrastructures Department will contact the End-User directly in order to realise the “raccordement souterrain”.

Before the actual beginning of the “raccordement souterrain”, the End-User will be required to confirm its consent to the applicable charges, as indicated in the letter within the meaning of Article 12.2 above.

Schedule 13 – Access to EPT’s End-Users account numbers

1. The EPT “account number” and the EPT “customer number” are indicated on every EPT’s monthly telephone bill.
2. This information can also be accessed by End-Users and Operators through a special search engine published on EPT’s Website covering Operator services in the non protected area at the address:

« www.pt.lu ->Telecom-> Operators-> Regulatory-> Customer numbers
3. To obtain the required information the phone number and the birthday date of the account owner have to be provided.
4. If the provided data match to the data stored in the EPT’s database, the search engine will provide the “account number” and the “customer number” of the account owner.
5. If the combination of the provided information does not match, the search engine will return the message “Phone number and birthday date do not match, please check your data before trying another time”
6. If the phone number introduced does not exist in the EPT’s data base (e.g. the number has already been ported to another operator) , the search engine will indicate the message “Phone number does not exist in the EPT database “
7. If the provided phone number exists but no data regarding the birthday of the account owner is available in the EPT’s data base, the search engine will indicate the message “Birthday date not available in the EPT data base, please contact the EPT no.8002 8004”. In this case the Operator or the End-User can request the required information by phone. The account and customer number information will be transmitted by EPT after receiving by fax (no.: 8002 8005) a copy of the account owners identity card.
8. If the phone number provided through is not stored in the EPT database as an number for residential customers, the search engine will indicate the message “You are not listed as a residential customer in the EPT database”